

# Hydraulic Rotary Screw & Reciprocating Compressors

## Owner's Manual



**Introduction:** Congratulations on the purchase of your new air compressor. The air compressor is precision built from the finest materials using the finest state of the art design, and high tech engineering available today. Quality, performance and trouble free operation will assure you a dependable supply of air power on demand.

Check [industrialgold.com](http://industrialgold.com) for most up to date manual and compressor service and technical information

**CAUTION:** Read this manual carefully before operating or servicing this air compressor, to familiarize yourself with the proper safety, operation, and standard operating procedures of this unit. **FAILURE TO COMPLY WITH INSTRUCTIONS IN THIS MANUAL COULD RESULT IN THE VOIDING OF YOUR WARRANTY, AND PERSONAL INJURY, AND/OR PROPERTY DAMAGE. THE MANUFACTURER OF THIS AIR COMPRESSOR WILL NOT BE LIABLE FOR ANY DAMAGE BECAUSE OF FAILURE TO FOLLOW THE INSTRUCTIONS IN THIS MANUAL.** By following the instructions and recommendations in this manual you will ensure a longer and safer service life of your air compressor.

**NOTICE:** All air compressors must be installed by a qualified and trained technician. If you need a qualified technician, call 800-531-9656 or 972-352-6304. Improper installation may result in damage to the compressor, personal injury, and will void the warranty of the compressor package.

If you have questions or need clarification about this manual or your compressor call 800-531-9656

***Do not operate compressor outdoors in wet weather***

## Industrial Gold

Quality Air Compressors at a Great Price.

[industrialgold.com](http://industrialgold.com) ■ 1-800-531-9656 ■ Fax 972-352-6364

© Industrial Gold



Scan to visit our website



## Contents

Additional Information.....	2
Safety Precautions and Warnings.....	3

## Installation

Description of a Compressor.....	7
Receiving and Uncrating Your Compressor.....	9
Compressor Installation.....	10
Startup Preparation and Procedures.....	11

## Maintenance - Reciprocating

Stopping for Maintenance or Service.....	12
Common Maintenance Parts.....	12
Maintenance Procedures.....	13
Adjusting Belt Tension.....	19
Adjusting Pulley Alignment.....	19

## Maintenance - Rotary Screw

Stopping for Maintenance or Service.....	14
Common Maintenance Parts.....	14
Maintenance Procedures.....	15
Adjusting Belt Tension.....	19
Adjusting Pulley Alignment.....	19

## Other

Troubleshooting Common Issues.....	20
Parts Diagram.....	21
Warranty.....	26
Installation Sheet.....	27

## Additional Information

For compressor pump information see pump specific manual.

For installation instructions see Install Guide.

For compressor package wiring diagram contact manufacturer.

For compressor parts breakdown see website ([industrialgold.com](http://industrialgold.com)) or contact compressor manufacturer.

**NOTICE:** Air compressors must be installed by trained installation personnel. Installation sheets must be sent back in for warranty activation. If you need help finding a qualified technician to properly perform installation, call 800-531-9656 or 972-352-6304.

**WARNING:** Read all installation steps in install guide, and compressor package manual prior to uncrating or installing compressor package. Failure to do so can result in personal injury or damage to compressor package.

**NOTICE:** All compressor air receivers should be inspected by a certified pressure vessel technician at least once per year, to check for leaks, weak points in the metal or any other deformity of the air receiver. If at any time a receiver appears out of conformance with ASME/CRN certification or a deformity is believed to have developed no matter how minor it may appear the tank should be locked out of service immediately and replaced with a certified ASME/CRN certified air receiver immediately before the compressor can be put back into service. The receivers should have a general inspection weekly as part of normal service.

## SAFETY PRECAUTIONS AND WARNINGS

Listed are some, but not all safety precautions that must be observed with compressors and compressed air systems. Failure to follow any of these warnings may result in severe personal injury, death, property damage and/or compressor damage.

**Air from this compressor will cause severe injury or death if used for breathing or food processing. Air used for these processes must meet OSHA 29 CFR 1910 or FDA 21 178.3570 regulations.**

**This compressor is designed for use in the compression of normal atmospheric air only. No other gases, vapors or fumes should be exposed to the compressor intake, nor processed through the compressor.**

Relieve all pressure internal to the compressor prior to servicing.

Do not depend on check valves to hold system pressure.

A properly sized safety valve must be installed in the discharge piping ahead (upstream) of any shut-off valve (block valve), heat exchanger, orifice or any potential blockage point. Failure to install a safety relief valve could result in rupturing or explosion of some compressor or safety component.

Do not change the pressure setting of the safety relief valve, restrict the function of the safety relief valve, or replace the safety valve with a plug.

Over pressurization of some system or compressor component can occur, resulting in severe personal injury, death and property damage.

Never use plastic pipe, rubber hose, or soldered joints in any part of the compressed air system. Failure to ensure system compatibility with compressor piping is dangerously unsound.

Never use a flammable or toxic solvent for cleaning the air filter or any parts.

Do not attempt to service any part while the compressor is operating.

Do not operate the compressor at pressures in excess of its rating.

Do not remove any guards while the compressor is operating.

Observe gauges daily to ensure compressor is operating properly.

Follow all maintenance procedures and check all safety devices on schedule.

Compressed air is dangerous, do not play with it.

Use the correct lubricant at all times.

Always wear proper safety equipment when using compressed air.

Always install compressor to all local applicable electric codes.

Do not exceed pressure ratings for hydraulic or air systems.

Use only rated hoses and fittings.

Disconnect hydraulic power before maintenance.

Do not operate with leaks, damaged hoses, or loose connections.

Be cautious of hot surfaces during operation.

**WARNING:** Always wear proper protective eyewear, hearing protection and safety clothing when working around the compressor package. No loose or baggy clothing should be worn around compressor package at any time.

**WARNING:** On Electric motor powered air compressors make sure electrical system is up to National Electric Code (NEC) prior to installing compressor system. Failure to install a compressor with a proper NEC electrical system can cause personal injury, compressor package damage and void compressor package warranty

**NOTICE:** To ensure full compressor tank warranty all tank mounted compressor packages must be mounted on factory approved vibration isolation pads. A compressor should NEVER be installed while still on or in its original packaging. Failure to properly install the compressor system with approved vibration isolation pads will result in the compressor tank warranty being void.

**WARNING:** Industrial Gold compressors can operate at pressures from 0-250psi depending on the compressor package design and build specifications. Always verify that the system the compressor is installed into can handle the maximum operational pressure the compressor. NEVER install a compressor in a system that can not handle the compressors maximum operating pressure.

**WARNING:** Compressed air is extremely dangerous when not properly used or installed. Always make sure a trained compressed air professional has looked over the air system prior to use. Improper installation or use of compressed air can cause bodily injury or death. NEVER pressurize an object that was not designed to be pressurized. Pressurizing objects not properly engineered for the maximum operating pressure of the compressor system can cause bodily injury or death.

**WARNING:** Never apply air pressure to compressor crank case, always make sure crank case vent is clear and free from obstructions. Adding pressure to the crank case can cause serious bodily injury or death.

**WARNING:** Never operate a compressor in a moving vehicle or towable object in motion. Doing so can damage the compressor, compressor drive components, or auxiliary parts on the compressor package. Operating the compressor in a moving vehicle or towable object can cause serious bodily injury or death.

**WARNING:** Check function of safety valves, weekly to insure proper function, replace immediately if faulty or damaged.

**WARNING:** (Compressors Packaged with NEMA 7 Components)

Industrial Gold certifies that the electric motor, electrical enclosure and electrical conduit are rated for NEMA7/hazardous locations. (Only for applicable packages with NEMA7 added components)

Air compressors have multiple moving parts and potential points of contact that could create an ignition source. The compressor pumps are manufactured with ferrous metals and in some cases multiple moving parts can come in contact with one another causing an ignition source. Industrial Gold does not guarantee this will not occur. Lack of maintenance or care can result in conditions that could also cause ignition sources.

Industrial Gold only guarantees that the electric motor, electrical enclosure and electrical conduit are rated for NEMA7 hazardous location. Industrial Gold accept no other responsibility for the rating of the package.



**Safety valves are to protect system integrity in accordance with ASME Codes and ANSI B19.3 safety standards. Failure to use safety valves of the proper capacity and pressure will cause severe personal injury or death.**

**SAFETY VALVES:** Safety valves are pressure relief valves and should be sized and purchased with a pressure setting to protect the weakest link in the system. Never change the pressure setting, only the safety valve manufacturer is qualified to make a change. Safety valves are to be placed ahead of any potential blockage point which includes but is not limited to, shutoff valves, heat exchangers, pulsation dampeners, and discharge silencers.



CAUTION

**Failure to properly size, set and install pressure relief valves can be fatal.**



CAUTION

**ASME coded pressure vessels must not be modified, welded, repaired, reworked or subjected to operation conditions outside the nameplate ratings. Such actions will negate code status, affect insurance status and may cause severe personal injury, death, and property damage.**

### **PRESSURE VESSELS**

Air receiver tanks and other pressure containing vessels such as, but not limited to, pulsation bottles, heat exchangers, moisture separators and traps, shall be in accordance with ASME Boiler and Pressure Vessel Code Section VIII and ANSI B19.3 Safety Standards.



CAUTION

**Relieve compressor and system air pressure by opening the appropriate manual relief valve prior to servicing.**  
**Failure to relieve all system pressure may result in severe personal injury, death and property damage.**

### **MANUAL RELIEF AND SHUTOFF VALVES**

Install a manual relief valve to vent the compressor to atmosphere. In those instances where the air receiver tank services a single compressor, the manual relief valve can be installed on the receiver. These valves are to be designed and installed as to permit maintenance to be performed in a safe manner. Never substitute a check valve for a manual shut-off valve (block valve) if the purpose is to isolate the compressor from a system for servicing.



**Guards must be fastened in place before starting the compressor and never removed before cutting off and locking out the main power supply.**

## **GUARDS**

All mechanical action or motion is hazardous in varying degrees and needs to be guarded.

Guarding must be in compliance with OSHA Safety and Health Standards 29 CFR 1910.219 in OSHA manual 2206 and any state or local code.



**Excessive speed of the compressor or driver can be lethal. Never operate the compressor beyond the manufacturer's recommendation.**

**Bursting of the flywheel may be the greatest threat because the normal guard may not contain all the pieces.**

**Crankshaft and connecting rod breakage is a possibility and compressor efficiency, valve life and bearing life will be abnormally reduced.**

## **DRIVES**

It is important that the compressor and motor pulleys are aligned properly and the V belt is correctly tensioned.

Improper pulley alignment and belt tension are causes for motor overloading, excessive vibration, and premature belt and/or bearing failure.

**Removal or painting over safety labels will result in uninformed conditions. This may result in personal injury or property damage. Warnings signs and labels must be provided with enough light to read, conspicuously located and maintained for legibility. Do not remove any warning, caution, or instructional material attached.**

**Provisions should be made to have the instruction manual readily available to the operator and maintenance personnel. If for any reason any part of the manual becomes illegible or if the manual is lost, have it replaced immediately. The instruction manual should be periodically read to refresh one's memory, it may prevent a serious or fatal accident.**

## Description of Compressor - Reciprocating

### What is a reciprocating compressor?

A reciprocating compressor is a piston type pump which develops pressure from the action of a piston moving through a cylinder. The cylinder(s) may be vertical, horizontal or angular.

When air is drawn in from the atmosphere and compressed to its final pressure in a single stroke, the compressor is referred to as a "single stage" pump. Single stage units normally are used in the 90 to 125 PSI range and are available as single or multi-cylinder (twin cylinder) compressors.

When the air drawn from the atmosphere is compressed first to an intermediate pressure, and then further compressed to a higher pressure, it is done in a "two stage" pump. These cylinders are unequal in size and the first stage always takes place in the larger, low pressure cylinder. From there it passes through the inner cooler to the smaller, high pressure cylinder. The cycle is completed as the air then moves through the after cooler and discharge line into the tank. Two stage compressors are generally used for pressure ranges from 100 to 175 PSI and deliver more air per horsepower at these pressures. This increase in efficiency is partially due to the heat dissipated as the air passes through the inner cooler.

### Cooling

Our reciprocating compressors are cooled by fan blades, incorporated into the driven sheave (pulley), blowing air across the intercooler, after cooler, and cylinder head.

### Controls

Stop/Start Receiver or plant air system pressure is controlled within limits by a pressure switch automatically stopping and starting the compressor as the air pressure reaches a maximum preset pressure (cut out) and then drops to a minimum pressure (cut in).

## Description of Compressor - Rotary Screw

### What is a rotary screw compressor?

A rotary screw compressor is a positive displacement, oil flood lubricated, helical rotary screw type unit employing a single stage of compression. The components include a housing or stator, two rotors or screws, bearings and bearing supports.

In operation, two helical grooved rotors mesh to compress air. Inlet air entering the compressor becomes trapped between the lobes of the rotors. As the rotors turn, this trapped volume of air is reduced in volume, or compressed, and is pushed to the discharge end of the compressor. This process delivers smooth flowing air at full pressure to the receiver.

During the compression cycle, oil is injected into the compressor for the purposes of lubricating, cooling, and sealing. Compressed air laden with oil leaves the compressor through a discharge port designed to provide optimum performance within the desired pressure range.

### Air/Oil System

The air/oil system is almost completely contained within the compressor housing. Within or directly attached to the housing are the air filter, oil filter and the air/oil separator element.

**NOTICE:** Air compressors must be installed by trained installation personnel. Installation sheets must be sent back in for warranty activation. If you need help finding a qualified technician to properly perform installation, call **800-531-9656** or **972-352-6304**.

## Description of Compressor - Rotary Screw

### Air Filter

The air filter is a high efficiency ring style located on top of the inlet valve of the compressor. It will provide nearly constant efficiency of filtration at all load conditions. The element has a high dirt holding capacity for a long life. It is specially treated to be insensitive to heat, cold, water, and oil.

### Oil Filter

The oil filter is a 10-micron spin-on style. It is sized to maintain system cleanliness and to give good service life. The housing is equipped with a bypass to ensure that there is oil flow on startup. The restriction created at the filter will have a direct effect on the operating temperature of the compressor. So you must be sure to maintain it.

### Air/Oil Separator

This unit utilizes a spin-on air/oil separator to make maintenance much more convenient than the element in vessel design. This does not diminish its operating efficiency. In fact, the separation of the element from the pre-separation tank enhances the performance. The purpose of the separator is to remove aerosols.

The vapor pressure of the oil, the operating temperature of the unit, the operating pressure of the unit and the operating cycle will effect its performance.

### Minimum Pressure Valve

As the compressed air leaves the compressor, it goes through a minimum pressure valve. This is set to maintain at least 85 psig (586kPa) in the sump when the compressor is running. This is to ensure that there is pressure to force the oil out of the sump and through the oil system so that sufficient oil is injected into the compressor. It is also necessary to provide good air/oil separation. The valve acts as a check valve to prevent back flow into the compressor from the plant system.

### Cooling

The compressor has an air-cooled after-cooler as standard.

Heat loads and cooling airflow rates must be accommodated. Refer to table on page 7.

The compressor is an oil flooded unit. The oil lubricates, seals, and cools the internals of the compressor. In cooling, it picks up the heat generated by the compression process and the mechanical friction from the bearings. So the oil must be cooled to within 60° F of the ambient temperature.

The after-cooler has been designed for a minimum approach of 15°F.

### Controls

Our rotary screw units are equipped with a normally closed inlet valve. This means that when the unit is started, the inlet valve remains closed while the unit builds up pressure by means of a bypass line. After startup the inlet valve is controlled by a simple on/off action of a pressure switch working with a solenoid valve.

For instrumentation, the unit has a discharge temperature gauge and air pressure gauge.

**NOTICE:** Air compressors must be installed by trained installation personnel. Installation sheets must be sent back in for warranty activation. If you need help finding a qualified technician to properly perform installation, call 800-531-9656 or 972-352-6304.

## HEAT LOAD OF COMPRESSOR

MODEL	TOTAL HEAT LOAD B/Min	REQUIRED FLOW CFM
5-7.5HP	805	1767
10HP	1064	2335
15HP	1587	3483
20HP	2104	4619
25HP	2727	5985
30HP	3250	7134
40HP	4256	9341
50HP	5325	11,700
60HP	6390	14,040
75HP	7988	17,550
100HP	10,650	23,400
125HP	13,313	29,250
150HP	15,975	35,100
200HP	21,300	46,800
250HP	26,625	58,500
300HP	31,950	70,200

## Receiving and Uncrating of your Compressor

### BEFORE UNCRATING THE COMPRESSOR THE FOLLOWING STEPS SHOULD BE TAKEN.

1. Immediately upon receipt of the equipment, it should be inspected for damage that may have occurred during shipment. If any damage is found, demand an inspection immediately by an inspector from the carrier. Ask the carrier how to file a claim for damages.
2. Insure that adequate lifting equipment is available for moving the machinery. Never attempt to move compressor without proper lifting equipment.
3. Read the compressor nameplate to be sure the compressor is the model and size ordered.
4. Read the motor nameplate to be sure the motor is compatible with your conditions.



**Improper lifting can result in component or system damage or personal injury.**

**Follow good shop practices and safety procedures.**



**Under no circumstances should a compressor be placed in an area that may be exposed to a flammable, toxic, volatile or corrosive atmosphere nor should flammable, toxic, volatile or corrosive agents be stored near the compressor.**

## Compressor Installation

### Hydraulic System Requirements

**Flow:** The compressor package is designed to operate at a specific flow rate (GPM) as stated on the unit's data plate or specification sheet. Hydraulic flow must match this rated value.

**Pressure:** The hydraulic system's pressure must not exceed the its rated operating pressure (PSI). Refer to the specification sheets of the hydraulic system and the compressor package.

**Return Line:** Free flow to tank (low backpressure)

### Mounting

- Mount the unit on a solid, level surface or vehicle frame.
- Secure using vibration-isolating mounts.
- Ensure adequate airflow around the unit for cooling.

### Hydraulic Hookup

- **INLET - Pressure Line:** Connect to existing hydraulic system output.
- **RETURN:** Connect to existing hydraulic reservoir with low restriction.
- Install an in-line filter and relief valve.

### Air System Hookup

- Connect air output to storage tank or distribution manifold.
- Install regulator and moisture separator if needed.

### Air Induction System

Do not locate the compressor where it could ingest or ignite toxic, explosive or corrosive vapors, ambient air temperatures exceeding 110°F, water, or extremely dirty air. Ingestion of any of the above noted atmospheres by the compressor could jeopardize the performance of the equipment and all personnel exposed to the total compressed air system.

Destructive pulsations can be induced by reciprocating compressors that will damage walls and break windows. Pulsation can be minimized by adding a pulsation dampener on the inlet side of the compressor.

### Noise

Noise is a potential health hazard that must be considered. There are local and federal laws specifying maximum acceptable noise levels that must not be exceeded. Most of the noise from a reciprocating compressor originates from the air inlet point. Excessive noise can be greatly reduced by installing an intake noise silencer. Intake noise silencers are available from the compressor manufacturer.

### Piping Fitup

Care must be taken to avoid assembling the piping in a strain with the compressor. It should line up without having to spring or twist into position. Adequate expansion loops or bends should be installed to prevent undue stresses at the compressor resulting from the changes between hot and cold conditions. Pipe support should be mounted independently of the compressor and anchored as necessary to limit vibration and prevent expansion strains.

**NOTICE:** Air compressors must be installed by trained installation personnel. Installation sheets must be sent back in for warranty activation. If you need help finding a qualified technician to properly perform installation, call 800-531-9656 or 972-352-6304.

## Start Up Preparation & Procedures

The following steps must be adhered to before putting the compressor into operation. **Failure to perform the checks may result in serious injury or death, property damage and/or mechanical failure.**

1. Remove all loose pieces and tools around the compressor installation.
2. Check oil level in compressor pump, add as necessary.  
Rotary screw compressors: Drain off condensate from the sump and check the oil level. Refill as necessary.
3. Check all connections: hydraulic, air, and electrical (if any).
4. Check to make sure all safety relief valves are in place and operational.
5. Check to be sure all guards are in place and securely mounted.
6. Check that the hydraulic system is at proper fluid level.
7. Open all manual shut-off valves (block valves) at and beyond the compressor discharge.
8. Ensure air tank drain is closed.
9. Rotary screw compressors: turn Load/Unload switch to Unloaded position.
10. Power ON the hydraulic system.  
Rotary screw compressors: Let compressor run for 15 seconds unloaded. Turn Load/Unload switch to Load position.
11. Monitor pressure gauges (hydraulic & air).
12. Adjust air regulator to desired output.
13. Compressor will run and pressurize system.
14. Monitor for overheating or unusual noise.

### Stopping (Rotary Screw)

1. Turn Load/Unload switch to Unloaded position. Make sure the compressor is fully unloaded before Step 2.
2. Turn the hydraulic system OFF

The following procedures should be followed for start-up of a new installation, or after changes have been made to an existing installation, and/or after service repair work has been performed.

1. Instructions in addition to those contained within this manual, supplied by manufacturers of supporting equipment, must also be read and understood before start-up.
3. Drain moisture from air receiver and traps.
4. Start compressor and watch for excessive vibration or strange noises.  
If either is observed, stop the compressor immediately and correct.
5. Check air receiver or system pressure.
6. Manually activate safety relief valves by pulling ring or lever.
7. Check operation of controls.
8. After two days of operation check belt tension, air piping for leaks, compressor pump oil level.

#### **WARNING:**

**Do not operate compressor with blocked cooling fins or filters.**

**Do not run compressor without hydraulic oil or with dirty oil.**

## Stopping for Maintenance or Service - Reciprocating

 <b>CAUTION</b>	<p>Never assume the compressor is ready for maintenance or service because it is stopped.</p> <p>Automatic stop-start control may start the compressor at any time!</p>
---	---

### THE FOLLOWING PROCEDURE SHOULD BE FOLLOWED TO MAXIMIZE SAFETY WHEN PREPARING FOR MAINTENANCE OR SERVICE.

1. Turn hydraulic system OFF
2. Close shut-off valve (block valve) between receiver and compressor, or receiver and air system, to prevent any back-up of air flow into the area to be serviced.
3. Lock open manual vent valve and wait for the pressure in the area to be serviced (compressor, receiver, etc.) to be completely relieved before starting service. The Manual vent valve may be the drain valve in the receiver. NEVER remove a plug to relieve the pressure.
4. Open all manual drain valves within the area to be serviced.
5. Wait for the unit to cool before starting service, (temperatures at 125° F can burn the skin, some surface temperatures exceed 400° F when the compressor is working).
6. Clean up all oils spills immediately to prevent slipping. (Mark spill area accordingly.)

### Common Maintenance Parts

CA1(U) PUMP	Part Number
Reciprocating Pump Oil	IAT-30100
Air Filter Element	IAT-CA-712114
Air Filter Housing	IAT-CA-712140

PUMP OIL CAPACITIES	Ounces
CA1(U)	2.5 Quarts
CA2(U)	3.5 Quarts

CA2(U) PUMP	Part Number
Reciprocating Pump Oil	IAT-30100
Air Filter Element	IAT-CA-712114
Air Filter Housing	IAT-CA-712140

Part numbers subject to change/update always consult factory prior to ordering

**NOTICE:** Air compressors must be installed by trained installation personnel. Installation sheets must be sent back in for warranty activation. If you need help finding a qualified technician to properly perform installation, call 800-531-9656 or 972-352-6304.

## Compressor Maintenance - Reciprocating

**WARNING:** To avoid personal injury, always shut OFF the hydraulic system, and relieve all air pressure from the system before starting any service or maintenance on the compressor.

### DAILY:

- Drain the receiver - condensation will accumulate in the tank daily, and should be drained at least once a day. This is done to reduce corrosion of the tank from the inside. Always wear protective eye wear when draining the tank.
- Inspect hoses/fittings
- Check hydraulic oil level
- Check pump oil level - For the units that have a sight glass the oil level, non running units should be no lower than the ½ way on the sight glass. If it is lower then the ½ way, add oil until it is at least ½ way up the sight glass.
- Check unit for any unusual noise or vibrations.

### WEEKLY:

- Clean air filter- this will ensure that no dirt or heavy particulate makes its way into the compressors valve assemblies.
- Clean external parts of compressor - this helps to ensure proper cooling and prevents rust and corrosion on critical parts.
- Check safety valves - this is to ensure they are not stuck in place and operating properly.

### MONTHLY:

- Inspect complete air system for leaks - this is done to make sure the compressor does not get out of its duty cycle due to air leak in the system.
- Inspect oil for contamination - this is done to ensure that harmful deposits do not build up in the oil.
- Check belt tension - this is done to ensure the belt do not fail pre-maturely, tighten as needed to ensure they do not slip. If belts are loose, tighten per instructions on next page. Failure to tighten can cause pre-mature belt failure.

### EVERY 250-500 HOURS:

- Change hydraulic fluid/filter

### EVERY 3 MONTHS OR 500 HOURS:

(WHICHEVER COMES FIRST)

- Change oil - this is done to ensure that the compressor is adequately lubricated and that the oil in the machine does not deteriorate past factory specifications.
- Inspect valve assemblies - this is done to prevent premature failure and clean out and carbon that can form in older valves.
- Inspect pressure switch for proper function.
- Inspect check valve for proper function and remove any carbon accumulation to prevent premature failure.
- Clean belt guard coolers (if equipped).

### LONG TERM STORAGE PROCEDURES:

(COMPRESSORS THAT WILL NOT BE USED FOR 60 DAYS OR MORE)

1. Drain hydraulic fluid from package/disconnect any hydraulic source from system.
2. Drain compressor oil and change filters, refill oil.
3. Check compressor intake for debris, clean out if needed (Cover compressor intake to prevent debris, insects, etc. from entering compressor intake).
4. Clean off compressor package.
5. Cover compressor to prevent debris from collecting on compressor and store in a location out of direct sunlight/rain/weather. Do not seal compressor cover as moisture may form and prematurely rust parts due to humidity not being able to escape.
6. If storage last 90 days or more, every 30 days manually rotate compressor pump/airend 1/4 turn.
7. If compressor stored longer than 120 days, inspect compressor intake and discharge valves on reciprocating. Inspect compressor check valve for operation.
8. Before putting compressor back into operation, change oil, change all filters, and check belt tension.
9. Follow install guide and proper start up procedures prior to putting air compressor back into service. (Fill out a new compressor install data sheet at time of re-installation or initial installation).

## Stopping for Maintenance or Service - Rotary Screw

 <b>CAUTION</b>	<p>Never assume the compressor is ready for maintenance or service because it is stopped.</p> <p>Automatic stop-start control may start the compressor at any time!</p>
---	---

### THE FOLLOWING PROCEDURE SHOULD BE FOLLOWED TO MAXIMIZE SAFETY WHEN PREPARING FOR MAINTENANCE OR SERVICE.

1. Turn hydraulic system OFF
2. Close shut-off valve (block valve) between receiver and compressor, or receiver and air system, to prevent any back-up of air flow into the area to be serviced.
3. Lock open manual vent valve and wait for the pressure in the area to be serviced (compressor, receiver, etc.) to be completely relieved before starting service. The Manual vent valve may be the drain valve in the receiver. NEVER remove a plug to relieve the pressure.
4. Open all manual drain valves within the area to be serviced.
5. Wait for the unit to cool before starting service, (temperatures at 125° F can burn the skin, some surface temperatures exceed 400° F when the compressor is working).
6. Clean up all oils spills immediately to prevent slipping. (Mark spill area accordingly.)

Note. If the compressor is turned off before being **FULLY UNLOADED** it can cause the unit to discharge oil into the air filter housing and could cause the air filter element to become contaminated. This may happen when using the emergency shut-off button and/or the on/off switch

### Common Maintenance Parts

ROTARY SCREW COMPRESSOR CONSUMABLES	AIR FILTER	OIL FILTER	SEPARATOR	OIL CAPACITY (GALLONS)
RS3	IAT-AF7	IAT-OF1	IAT-SE-1	1
RS6	IAT-AF8	IAT-OF5	IAT-SE-4	2.5
RS8	IAT-GCU55-AF	IAT-OF5	IAT-GCU55-SEP	5

**NOTICE:** Air compressors must be installed by trained installation personnel. Installation sheets must be sent back in for warranty activation. If you need help finding a qualified technician to properly perform installation, call 800-531-9656 or 972-352-6304.

## Compressor Maintenance - Rotary Screw

### DAILY:

- Check airend oil level - remove oil fill cap and check for proper level.
- Drain the receiver - condensation will accumulate in the tank daily, and should be drained at least once a day. This is done to reduce corrosions of the tank from the inside. Always wear protective eye wear when draining the tank.
- Inspect hoses/fittings
- Check hydraulic oil level
- Check oil cooler - check for proper air flow to keep unit cool, and clean if necessary.
- Check unit for any unusual noise or vibrations.

### WEEKLY:

- Clean air filter - this will ensure that no dirt or heavy particulate makes its way into the compressors valve assemblies.
- Clean external parts of compressor - this helps to ensure proper cooling and prevents rust and corrosion on critical parts.
- Check safety valves - this is done to ensure they are not stuck in place and operating properly.
- Check belts - turn off the compressor and inspect the belts for damage, excessive wear, and correct tension. Replace if necessary.
- Inspect compressor intake - never use gasoline, thinners or other flammable solutions to clean valves or related parts.
- Check to be sure the valves are seated against the sealing surface around each port. If the valves are not sealing, compressor capacity will be severely reduced.

### MONTHLY:

- Inspect complete air system for leaks - this is done to make sure the compressor does not get out of its duty cycle due to air leaks in the system.
- Inspect oil for contamination - this is done to ensure that harmful deposits do not build up in the oil.
- Check belt tension - this is done to ensure the belt does not fail pre-maturely, tighten them as needed to ensure they do not slip. If belts are loose, tighten per instructions on next page Failure to tighten can cause premature belt failure.

### EVERY 250-500 HOURS:

- Change hydraulic fluid/filter

### EVERY 3 MONTHS OR 500 HOURS:

(WHICHEVER COMES FIRST)

- Change oil filter - this is done to ensure that the compressor has proper oil level and that the oil in the machine does not deteriorate past factory specifications
- Check airend filter - change as needed.

### YEARLY OR EVERY 2000 HOURS:

(WHICHEVER COMES FIRST)

- Change oil - change with only CAS RS8000, or other factory approved lubricants.
- Clean oil cooler - this is done to ensure adequate cooling for the compressor air end.

### LONG TERM STORAGE PROCEDURES:

(COMPRESSORS THAT WILL NOT BE USED FOR 60 DAYS OR MORE)

1. Drain hydraulic fluid from package/disconnect any hydraulic source from system.
2. Drain compressor oil and change filters, refill oil.
3. Check compressor intake for debris, clean out if needed (Cover compressor intake to prevent debris, insects, etc. from entering compressor intake).
4. Clean off compressor package.
5. Cover compressor to prevent debris from collecting on compressor and store in a location out of direct sunlight/rain/weather. Do not seal compressor cover as moisture may form and prematurely rust parts due to humidity not being able to escape.
6. If storage lasts 90 days or more, every 30 days manually rotate compressor pump/airend 1/4 turn.
7. If storage lasts 120 days or more, inspect compressor intake and MPV valves.
8. Before putting compressor back into operation, change oil, change all filters, and check belt tension if belt driven.
9. Follow install guide and proper start up procedures prior to putting air compressor back into service. (Fill out a new compressor install data sheet at time of re-installation or initial installation).

## Maintenance Procedures - Rotary Screw



**Hot oil under pressure will cause severe injury, death, or property damage.**

**Be sure the compressor is shutdown and pressure relieved before attempting to remove the oil filter, separator, oil fill, or change the oil.**

### AIR FILTER

The air filter is the primary protection of the compressor from harmful dirt being ingested into the oil system. It needs to be looked at periodically for clogging or holes. The period for these inspections is dependent on the environment the machine is in.

For optimum life, it is recommended that an air filter restriction indicator be used. Service simply based on hours is not recommended.

### ELEMENT INSPECTION AND REPLACEMENT

1. Switch off the unit and disconnect the power to prevent accidental starting.
2. Allow one minute after stopping for the system to settle and the pressure to be relieved.
3. Loosen the nut that secures the cover and remove the cover.
4. Remove the element.
5. Place a bright light inside the element to inspect for damage or leak holes.
6. Inspect all gaskets and gasket contact surfaces of the housing. Correct any faulty conditions immediately.
7. Clean the housing with a damp cloth. Do not attempt to blow out dirt with compressed air.
8. Place a new element in the housing.
9. Replace the cover and tighten the nut.
10. Reset the filter indicator and the machine will be ready for operation.

If the compressor is turned off before being fully unloaded, it can cause the unit to discharge oil into the air filter housing causing it to become contaminated.

### OIL FILTER

The oil filter in the compressor system is a full flow replaceable canister type. This element protects the compressor bearings from grit and dirt ingress throughout the system. A dirty filter will cause an oil flow restriction that can result in high oil temperature and a unit shutdown.

### OIL FILTER REPLACEMENT

1. Switch off the unit and disconnect the power to prevent accidental starting.
2. Allow one minute after stopping for the system to settle and the pressure to be relieved.
3. Using a strap wrench, remove the old element and gasket.
4. Clean the gasket surface with a clean rag.
5. Apply a light film of oil to the new gasket.
6. Hand tighten the new element until the new gasket is seated in the gasket groove.
7. Continue to tighten by hand an additional  $\frac{1}{2}$  to  $\frac{3}{4}$  turn.
8. Reconnect power and restart the machine to check for leaks.

**NOTICE:** Air compressors must be installed by trained installation personnel. Installation sheets must be sent back in for warranty activation. If you need help finding a qualified technician to properly perform installation, call 800-531-9656 or 972-352-6304.

## Maintenance Procedures - Rotary Screw



**Hot oil under pressure will cause severe injury, death, or property damage.**  
**Be sure the compressor is shutdown and pressure relieved before attempting to remove the oil filter, separator, oil fill, or change the oil.**

### AIR/OIL SEPARATOR

The air/oil separator should be changed every 2000 hours, or when there is excessive oil vapor in the discharge air.

### SEPARATOR ELEMENT REPLACEMENT

1. Switch off the unit and disconnect the power to prevent accidental starting.
2. Allow one minute after stopping for the system to settle and the pressure to be relieved.
3. Using a strap wrench, remove the old element and gasket.
4. Clean the gasket surface with a clean rag.
5. Apply a light film of oil to the new gasket.
6. Hand tighten the new element until the new gasket is seated in the gasket groove.
7. Continue tightening by hand and additional  $\frac{1}{2}$  to  $\frac{3}{4}$  turn.
8. Reconnect power and restart the machine to check for leaks.

### OIL ANALYSIS

Oil analysis is an excellent tool to add to your compressor maintenance program. At regular intervals you submit lubricant samples to a qualified laboratory. From this you receive a detailed report showing the lubricant condition, wear metals, and contaminants. Changes in this information over time provides the basis for predictive compressor maintenance, saving you unplanned machine downtime and unnecessary oil changes.

### OIL RETURN SIGHT GLASS

During loaded operation there should be a visible flow in the sight glass. If there are no droplets visible then the orifice in this line needs to be checked. Oil not returned ends up in the plant air system.

### CHECKING OIL LEVEL AND ADDING COMPRESSOR OIL

1. Switch off the unit and disconnect the power to prevent accidental restarting.
2. Allow one minute after stopping the compressor for settling and the pressure to relieve.
3. Remove any dirt from around the fill cap, then remove the fill cap.
4. Inspect the o-ring in the cap for damage and cleanliness. Replace if necessary.
5. The oil should be between the bottom of the neck and the o-ring groove or 1/2 full in sight glass.
6. Replace the cap securely. Never put the cap on without tightening immediately.

### TO CHECK THE BELTS

1. Switch off the unit and disconnect the power.
2. Allow one minute after stopping the compressor for settling and the pressure to relieve.
3. Remove the belt guard.
4. Inspect for any fraying or cracking of the belts. If there is any, replace the belts.
5. Check the tension. It should be about 1/64" per inch of span between the sheaves

### TO CHANGE THE BELTS

1. Switch off the unit and disconnect the power.
2. Allow one minute after stopping the compressor for settling and the pressure to relieve.
3. Remove the belt guard.
4. Loosen the motor hold down bolts and the puller bolt and slide the motor toward the air end.
5. Remove the belt.
6. Replace with new belt.
7. Set the initial by sliding the motor back to its original position using the puller bolt and tighten the motor hold down bolts.

## Maintenance Procedures - Rotary Screw

### LUBRICANT

Your compressor has been filled and tested with CAS RS8000, a high quality compressor lubricant. It is a PAO with the advantage of extended service life, high temperature operation, easy start-up when cold, reduced sludge and lacquer buildup, and is completely compatible with all seals, gaskets, and other compressor materials.

### LUBRICANT SPECIFICATIONS

If you choose not to use CAS RS8000, for optimum life and warranty service your lubricant must meet the following specification:

Grade ISO.....	46
Viscosity@100°F, CST .....	46
Viscosity@210°F,CST .....	7.93
Viscosity Index.....	100 or more
Pour Point,°F.....	-20° or less
Flash Point, °F .....	400° or more
Fire Point, °F .....	450° or more
Rust Test ASTM-FG-665 A&B.....	Pass
Oxidation Test, ASTM0-D943.....	1500
Emulsion Test, ASTM-D1401 .....	10 Min.
Foam Test, ASTM.....	Pass

### CHANGING COMPRESSOR LUBRICANT

Regular maintenance of the oil filter and the air filter will help prolong the life of the lubricant.

1. Switch off the unit and disconnect the power to prevent accidental restarting.
2. Allow one minute after stopping the compressor for settling and the pressure to relieve.
3. Remove any dirt from around the fill cap, and then remove the fill cap. If the lubricant appears dirty or has a foul smell, it should be replaced.
4. Drain the lubricant from the bottom of the air/oil receiver. Oil will drain more quickly and completely if is warm from operation.
5. Close all drains and replace with fresh CAS RS8000 to the proper level.
6. Replace the fill cap and run the unit.
7. Switch off the unit and disconnect the power
8. Allow one minute after stopping the compressor for settling and the pressure to relieve.
9. Remove the fill cap to see if more lubricant should be added and to ensure that there are no leaks.

### MINIMUM PRESSURE VALVE

Then minimum pressure valve is a non-adjustable spring biased check valve. It has been designed to maintain a minimum sump pressure of 85 psig.

If the pressure is allowed to get too low, the oil carryover rate will increase and the separator could be damaged.

### FAN

Check the fan for cracking, loose rivets, and bent or loose blades. Make sure that it is securely mounted and tighten the mounting screws if loose. Replace a damaged fan immediately.

**NOTICE:** Air compressors must be installed by trained installation personnel. Installation sheets must be sent back in for warranty activation. If you need help finding a qualified technician to properly perform installation, call 800-531-9656 or 972-352-6304.

## Adjusting Belt Tension

Proper belt tension and pulley alignment must be maintained for maximum drive efficiency and for maximum belt life. The correct tensions exists if a deflection of ½ inch occurs by placing 10vlbs of force midway between the motor pulley and the compressor flywheel. This deflection can be adjusted by the following procedure. The pulley should be carefully aligned with the flywheel and set screws should be kept tight.

1. Remove the belt guard
2. Loosen the motor mounting bolts
3. Shift the motor to the point where the correct deflection exists
4. Retighten the motor mounting belts
5. Check to ensure that the tension remain correct after tightening
6. Re-install the belt guard. All moving parts must be guarded

NOTE: Drive belt tension and pulley alignment are done at the same time. They are discussed separately for clarity.

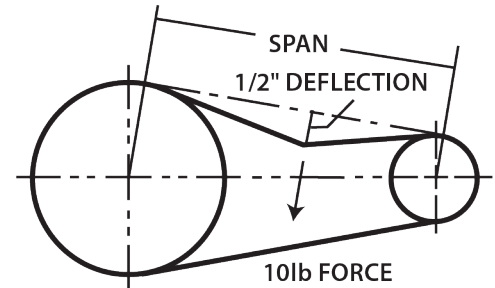

## Pulley Alignment

The figure to the side shows 3 examples of misaligned pulleys. To check pulley alignment, remove the belt guard and place a straightedge against the compressor flywheel, measure and record the distance from the straightedge to the edge of the drive belt. Then measure the distance to the edge of the drive belt on the motor pulley at the same edge. As long as both points measure the same distance the pulleys will be aligned if not you will need to move the pulley until its in alignment this may take a few tries. To re-align the pulley follow the steps below

1. Loosen the motor mounting bolts
2. Remove the belt guard
3. Loosen the set screw on the motor pulley
4. Align the motor pulley with the compressor flywheel
5. Re-tighten the motor pulley set screws
6. Adjust the proper belt tension
7. Re-tighten the motor mounting bolts
8. Re-install the belt guard

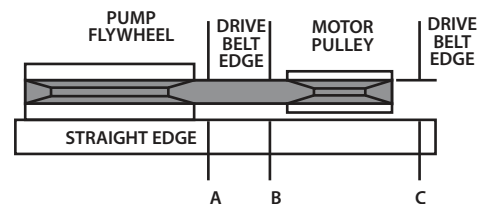
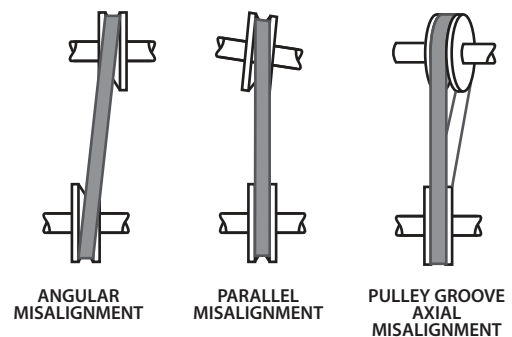

**NOTICE:** Air compressors must be installed by trained installation personnel. Installation sheets must be sent back in for warranty activation. If you need help finding a qualified technician to properly perform installation, call 800-531-9656 or 972-352-6304.

## Troubleshooting Chart

**NOTE:** Troubleshooting problems may have similar causes and solutions

**You should always contact an authorized service center before attempting to fix or repair your air compressor.**

**Always make sure hydraulic system is off before removing any inspection covers or plates or before servicing compressor.**

Problem	Possible causes	Solutions
Compressor does not build up to pressure	<ul style="list-style-type: none"> <li>A. Air leaks in shop</li> <li>B. Inlet valve malfunction</li> <li>C. Compressor belts slipping</li> <li>D. Air demand exceeds compressor output</li> <li>E. Improper pressure switch setting</li> <li>F. Solenoid valve malfunction</li> <li>G. Regulator set too low</li> </ul>	<ul style="list-style-type: none"> <li>A. Find and fix shop air leaks</li> <li>B. Check inlet valve for proper function</li> <li>C. Check belt tension and alignment/replace belt</li> <li>D. Check air usage requirements on machinery and check for shop air leaks</li> <li>E. Check pressure switch for proper setting</li> <li>F. Check solenoid for proper function</li> <li>G. Adjust regulator</li> </ul>
Compressor not running	<ul style="list-style-type: none"> <li>A. No hydraulic flow</li> <li>B. Blocked valve</li> </ul>	<ul style="list-style-type: none"> <li>A. Check hydraulic pump</li> <li>B. Inspect controls</li> </ul>
CFM (air flow) seems low	<ul style="list-style-type: none"> <li>A. Restricted air intake filter</li> <li>B. Inlet valve partially closed</li> <li>C. Air pressure switch set too high</li> <li>D. Insufficient oil flow</li> <li>E. Solenoid valve malfunction</li> </ul>	<ul style="list-style-type: none"> <li>A. Replace or clean the air filter</li> <li>B. Check inlet valve for proper function</li> <li>C. Check pressure switch for proper setting</li> <li>D. Check oil level, clean or replace oil filter, and inspect for oil line blockages.</li> <li>E. Replace faulty solenoid valve, or check wiring and connections.</li> </ul>
Hydraulic leak	<ul style="list-style-type: none"> <li>A. Loose fittings</li> <li>B. Worn seals</li> </ul>	<ul style="list-style-type: none"> <li>A. Replace or tighten fittings</li> <li>B. Replace seals</li> </ul>
High temperature shutdown	<ul style="list-style-type: none"> <li>A. High ambient air temperature around compressor</li> <li>B. Low oil level in compressor</li> <li>C. Plugged oil filter</li> <li>D. Restricted air flow over cooler</li> <li>E. Thermal bypass leaking</li> <li>F. Faulty temperature switch</li> </ul>	<ul style="list-style-type: none"> <li>A. Improve ventilation</li> <li>B. Check unit for proper oil level</li> <li>C. Replace oil filter</li> <li>D. Clean oil cooler</li> <li>E. Check thermal bypass for proper operation</li> <li>F. Check temperature switch for proper operation.</li> </ul>
Excessive belt wear	<ul style="list-style-type: none"> <li>A. Pulley out of alignment</li> <li>B. Improper belt tension</li> <li>C. Pulley damaged or loose</li> </ul>	<ul style="list-style-type: none"> <li>A. Realign pulley with flywheel</li> <li>B. Readjust belt tension</li> <li>C. Inspect pulley. Replace or tighten as needed</li> </ul>
Compressor pump knocking	<ul style="list-style-type: none"> <li>A. Loose motor pulley or compressor flywheel</li> <li>B. Low oil level in compressor pump</li> <li>C. Carbon build up on valve and piston</li> </ul>	<ul style="list-style-type: none"> <li>A. Tighten pulley or flywheel</li> <li>B. Keep oil level at recommended level for proper operation</li> <li>C. Replace valves. Only use factory recommended oil</li> </ul>

# H-BM40 Parts Breakdown

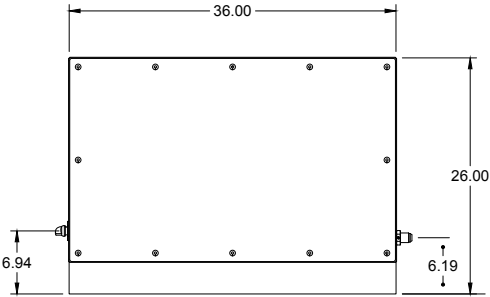
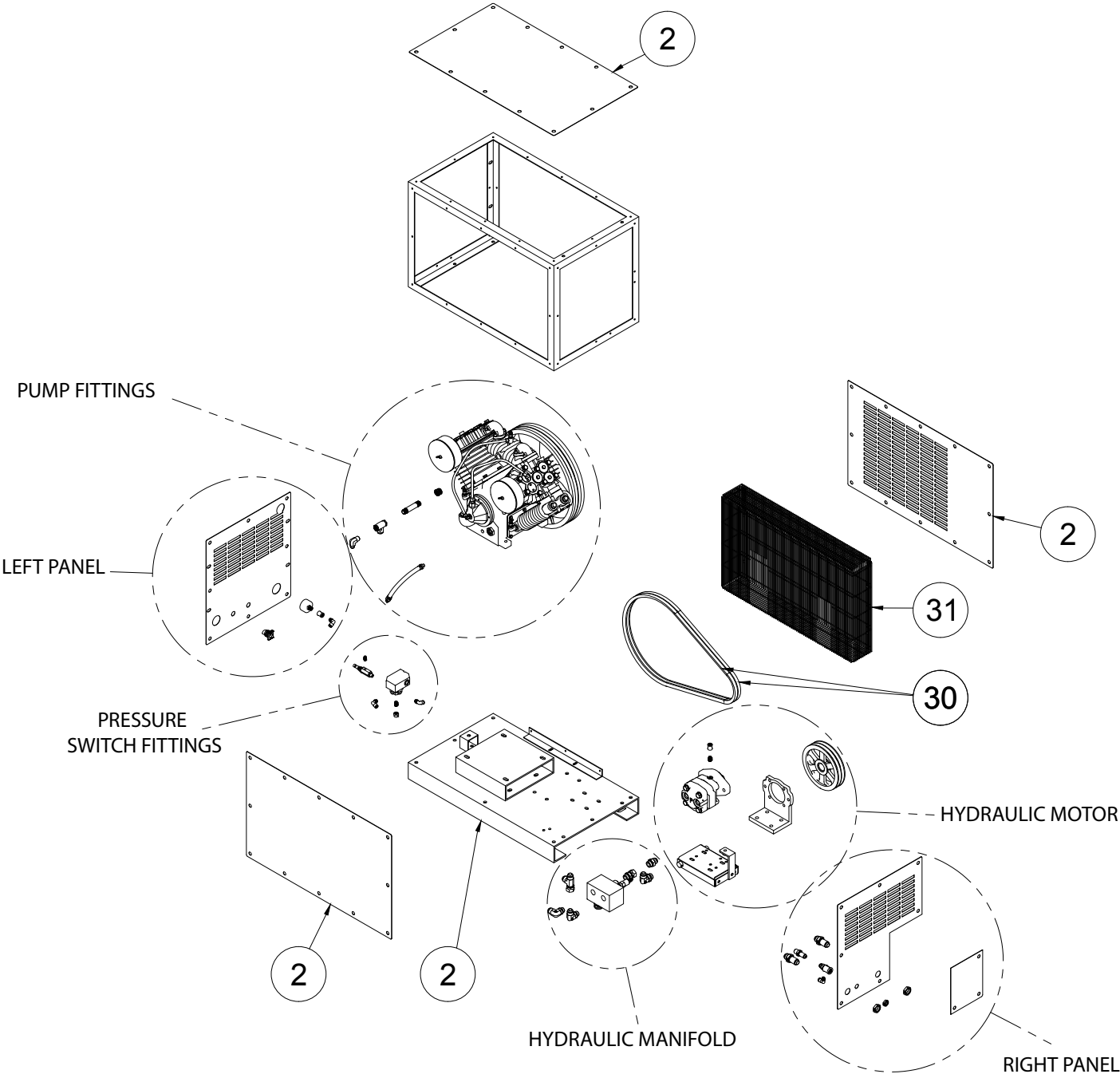

FRONT VIEW

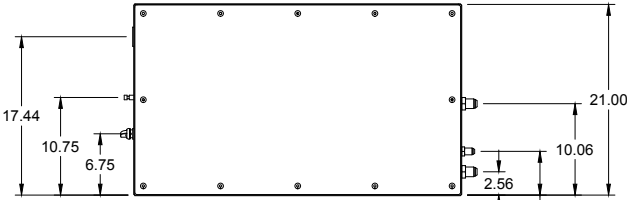

TOP VIEW

## H-BM40 Parts Breakdown

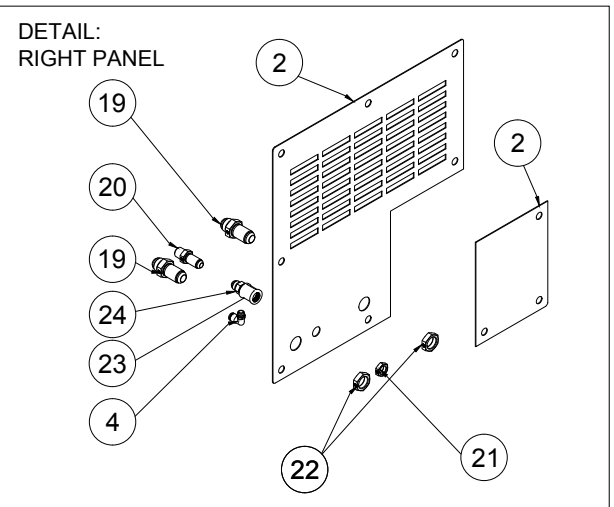
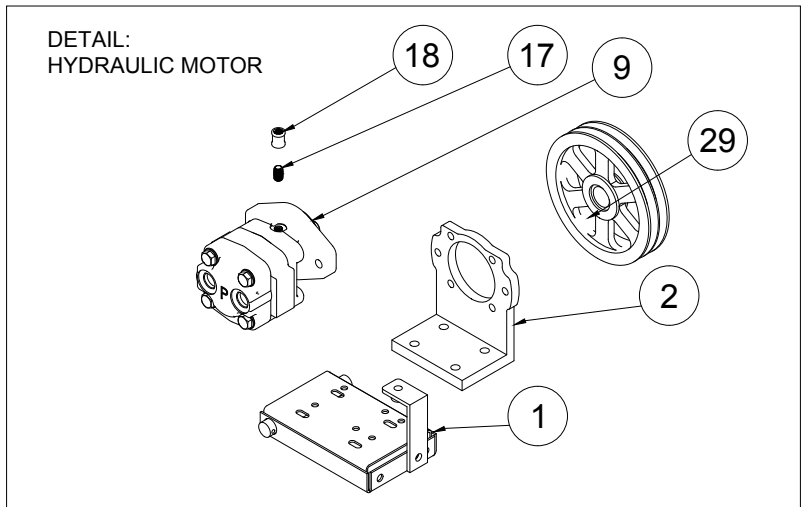
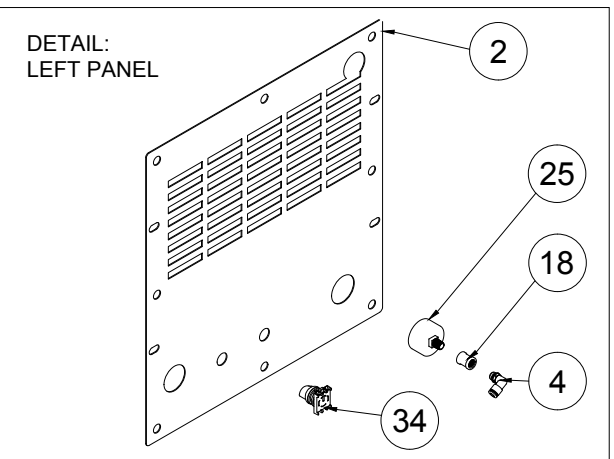
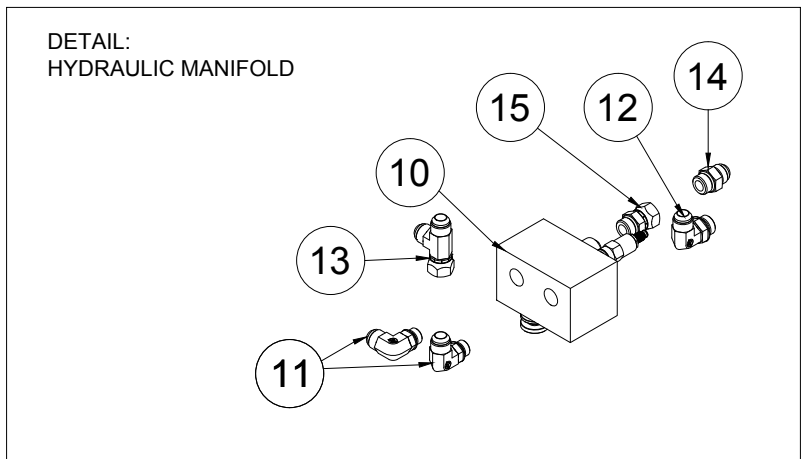
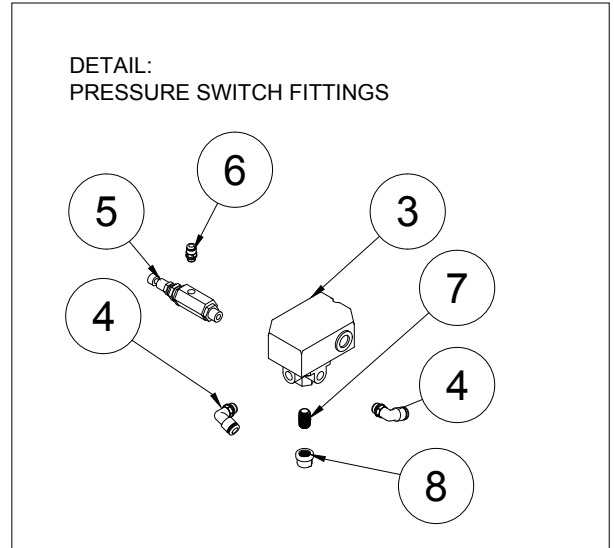
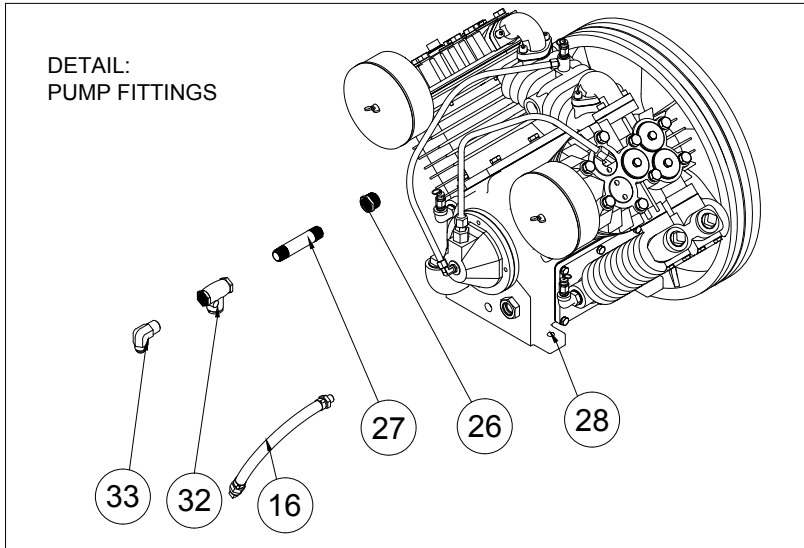

## H-BM40 Parts Breakdown

Item	QTY	Part Number	Description
1	1	IAT-56MP	56 FRAME MOTOR PLATE
2	1	IAT-H-BM40CA2	HYDRAULIC CA2 ENCLOSURE
3	1	IAT-LF10-4H2	PRESSURE SWITCH UNL 4P 145-175
4	4	IAT-BPC-2501-06-04	1/4 P X 3/8 COMP PUSH LOK 90
5	1	IAT-RCB-M-DC-160	PILOT VALVE 160 PSI
6	1	IAT-BPC-2404-04-02	1/8 P X 1/4 COMP PUSH LOC ST
7	1	IAT-PF1/4"CL	1/4" CLOSE NIPPLE GALV
8	1	IAT-PF1/4CAP	1/4" GALV CAP
9	1	IAT-HYD-2.5-R-34	HYDRAULIC MOTOR 2.5 CU/IN
10	1	HYDRAULIC MOTOR 2.5 CU/IN	HYDRAULIC MANIFOLD
11	2	IAT-6801-12-10-NWO	3/4" MJIC X 5/8" ADJ O-RING
12	1	IAT-6801-12-12-NWO	3/4" MJIC X 3/4" ADJ O-RING
13	1	IAT-6602-12-12-12	3/4 JIC M X 3/4 JIC M X 3/4 F
14	1	IAT-Y-6400-12-12	3/4" M ORING X 3/4JIC
15	1	IAT-Y-6402-12-12	5/8"BOSS X 3/4JICSWIVEL
16	1	IAT-OIL-DRAIN	OIL DRAIN
17	1	IAT-PF1/4"CL-SS	SS 1/4" CLOSE NIPPLE
18	2	IAT-PF1/4COUPLING	1/4" COUPLING
19	2	IAT-2700-12-12	3/4" x 3/4" MALE JIC STRAIGHT
20	1	IAT-2706-08-08	1/2" JIC BH X 1/2"NPT STRAIGHT
21	1	IAT-0306-08	1/2" BH LOCKNUT
22	2	IAT-0306-12	3/4" BH LOCKNUT
23	1	IAT-PF1/2COUPLER	1/2" COUPLER GALV
24	1	IAT-2404-08-08-H	1/2"MP X 1/2"M JIC STR WITH 1/4"
25	1	IAT-716010	2" BACK MT.LIQ.FILLED
26	1	IAT-PF3/4X1/2REDUCE	3/4" X 1/2" REDUCER GALV
27	1	IAT-PF1/2X4NIP	IAT-PF1/2X4NIP
28	1	IAT-CA2-U-S	10 HP BARE PUMP
29	1	IAT-2BK100X7/8 V2	FIXED BORE PULLEY
30	2	IAT-B68	V BELT
31	1	IAT-BG5X20X32EU	BELT GUARD 5HP ELEC. #2EU
32	1	IAT-CB50	1/2" INLINE CHECK VALVE
33	1	IAT-2501-08-08	1/2" MPT X 1/2" MJIC 90
34	1	IAT-M22M-WKV	ON/OFF SWITCH





## Certificate of Limited Warranty Reciprocating Compressors and Parts

All component parts on this compressor, installed by the manufacturer, are warranted to be free of defects in workmanship and material for a period of one year. Transportation charges are the responsibility of the purchaser. This warranty extends to the original purchaser of the compressor only. The purchaser must use Synthetic Reciprocating Compressor Oil, Part Number 30100, in the compressor for the duration of the compressor warranty. There are NO express warranties other than those contained in this limited warranty statement. Covered in the one year period of the warranty are defective parts and labor only. Part defects are limited to original parts only. The compressor warranty is void in the case of abuse, lack of proper service, incorrect application, incorrect installation, and neglect. Industrial Electric stationary compressors may be repaired on site as long as the compressor is not located further than 50 miles from the service center. The purchaser is responsible for any additional travel expense beyond 50 miles from the service center. Gas/Diesel Engine Driven, Single Stage Stationary, and Contractor Series compressors must be repaired at the closest service center to the compressor. The purchaser is responsible for any travel expense if they do not wish to bring the compressor to the service center. ALL "SPECIALTY COMPRESSOR" WARRANTY SERVICE MUST BE PERFORMED AT THE CLOSEST SERVICE CENTER TO THE COMPRESSOR. A "SPECIALTY COMPRESSOR" is any compressor packaged with options other than those that apply to the standard models in the catalog. Warranty labor for the first year is only covered for work performed Monday-Friday 8am-5pm excluding all major US holidays. BEFORE WARRANTY SERVICE IS PERFORMED, CONTACT THE MANUFACTURER TECH SUPPORT FOR FASTEST SOLUTION AND APPROVAL (800-531-9656 or 972-352-6304). Warranty repairs must be authorized by the manufacturer prior to work being performed. Unauthorized work may void the package warranty. The warranty claim form MUST be submitted for any potential warranty claim to be reviewed. A copy of the original invoice must be sent in with the warranty claim form.

**The limited warranty is not active until the installation sheet, included with the compressor manual, is properly filled out and returned. Failure to return the installation sheet will prevent the warranty from being active.**

## Certificate of Limited Warranty Parts Warranty

New parts purchased are warranted to be free from defects for a period of 1 year. Parts warranty is repair or replace only. Parts warranty is limited to the repair or replacement of the defective part only. No labor allowed for parts warranty. The defective part will be repaired or replaced. Freight and labor are not covered under the parts warranty. FOR A DEFECTIVE PART, CONTACT THE WARRANTY SERVICE CENTER (800-531-9656 or 972-352-6304).

## Certificate of Limited Warranty Rotary Screw Compressors

All component parts on this compressor, installed by the manufacturer, are warranted to be free of defects in workmanship and material for a period of one year. Transportation charges are the responsibility of the purchaser. This warranty extends to the original purchaser of the compressor only. The purchaser must use Synthetic Rotary Screw Oil, Part Number RS8000, in the compressor for the duration of the compressor warranty. There are NO express warranties other than those contained in this limited warranty statement. Covered in the one year period of warranty are defective parts and labor. Part defects are limited to original part only. The compressor warranty is void in the cases of abuse, lack of proper service, incorrect application, incorrect installation and neglect. Industrial Electric stationary compressors may be repaired on site as long as the compressor is not located further than 50 miles from the service center. The purchaser is responsible for any additional travel expense beyond 50 miles from the service center. Gas/Diesel Engine Driven compressors must be repaired at the closest service center to the compressor. The purchaser is responsible for any travel expense if they do not wish to bring the compressor to the service center. ALL "SPECIALTY COMPRESSOR" WARRANTY SERVICE MUST BE PERFORMED AT THE CLOSEST SERVICE CENTER TO THE COMPRESSOR. A "SPECIALTY COMPRESSOR" is any compressor packaged with options other than those that apply to the standard model in the catalog. The AIREND is covered by a 2 year warranty to be free from defects from manufacturing. This does not cover abuse, neglect, improper service, misapplication, or improper installation. An oil sample must be submitted with any AIREND warranty claim for verification. An "AIREND" is the rotors and bearings of the compressor. Warranty labor for the first year is only covered for work performed Monday-Friday 8am-5pm excluding all major US holidays. BEFORE WARRANTY SERVICE IS PERFORMED, PLEASE CONTACT MANUFACTURER TECH SUPPORT FOR FASTEST SOLUTION AND AUTHORIZATION (800-531-9656 or 972-352-6304). Warranty repairs must be authorized by the manufacturer prior to work being performed. Unauthorized work may void the package warranty. The warranty claim form MUST be submitted for any potential warranty claim to be reviewed. A copy of the original invoice must be sent in with the warranty claim form.

**The limited warranty is not active until the installation sheet, included with the compressor manual, is properly filled out and returned. Failure to return the installation sheet will prevent the warranty from being active.**

THIS POLICY IS LIMITED TO THE ITEMS ON THE INVOICE, WHICH IS ATTACHED WITH THIS DOCUMENT.

**THIS INSTALLATION SHEET MUST BE FILLED OUT AND RETURNED FOR WARRANTY TO BEGIN**

**Hydraulic Rotary Screw and Reciprocating Compressor Installation Sheet**

**Compressor & Installer**

Compressor Model # \_\_\_\_\_ Compressor Serial # \_\_\_\_\_

Installation Company: \_\_\_\_\_ Installation Technician: \_\_\_\_\_

Technician Signature: \_\_\_\_\_ Date: \_\_\_\_\_

**Hydraulic System & Installation Status**

Hydraulic Flow Rate: \_\_\_\_\_ GPM Operating Pressure: \_\_\_\_\_ PSI (Hydraulic)

Hydraulic Line Size - Pressure Line: \_\_\_\_\_ Hydraulic Line Size - Return Line: \_\_\_\_\_

Location of Install:  Truck Body (Open)  Van  Trailer  Box Truck  Other: \_\_\_\_\_

Vibration Pads Properly Installed:  Yes  No

**Performance**

Max Operating Pressure: \_\_\_\_\_ PSI Tank Drain Functional:  Yes  No  N/A

Checked All Air Fittings for Leaks:  Yes  No Checked Unit for Oil Leaks:  Yes  No

Checked Belt Tension After Start-Up:  Yes  No

Tank Fill Time: 0-125 PSI: \_\_\_\_\_ *Write N/A if pressure not applicable to unit*

0-150 PSI: \_\_\_\_\_ *Write N/A if pressure not applicable to unit*

0-175 PSI: \_\_\_\_\_ *Write N/A if pressure not applicable to unit*

All Install Steps Completed:  Yes  No *If No, Explain:* \_\_\_\_\_

**Send a copy of this completed installation sheet to manufacturer to begin warranty.**

**Include the following:**

- 1 image of the full install
- 1 image from each end of the compressor

Sales@industrialgold.com  
 Fax 972-352-6304  
 Or mail to  
 Industrial Gold  
 600 S. 2nd Ave Mansfield, TX, 76063



**Industrial Gold**

600 S 2nd Ave  
Mansfield, TX, 76063

**1-800-531-9656**

Fax 972-352-6364

**Quality Air Compressor at a Great Price.**