

Reciprocating Engine Driven Compressor/Generator Compressor/Generator/Welder

Owner's Manual

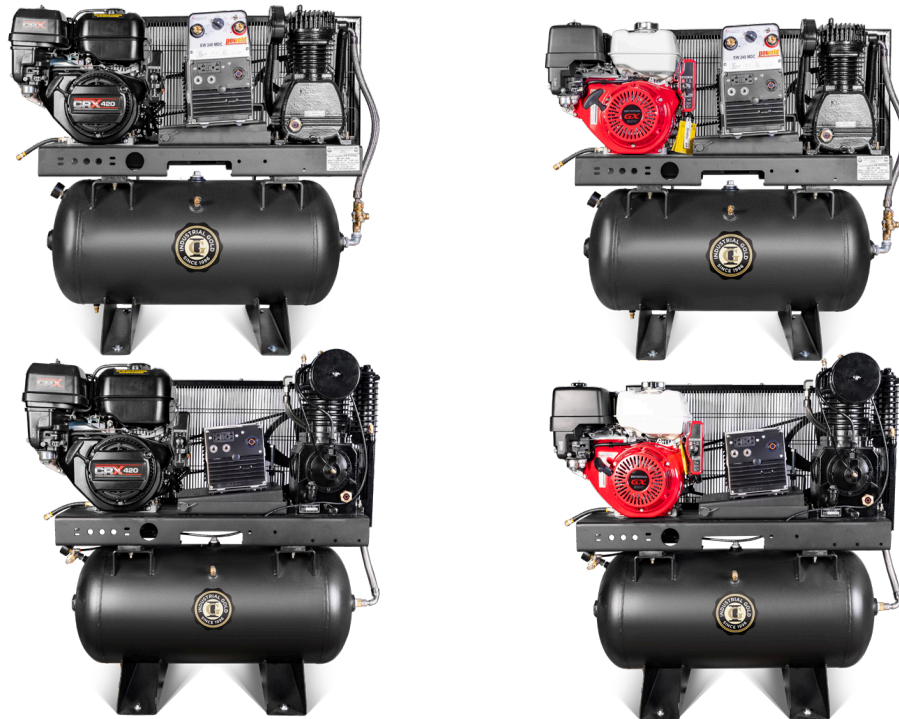

Introduction: Congratulations on the purchase of your new air compressor. The air compressor is precision built from the finest materials using the finest state of the art design, and high tech engineering available today. Quality, performance and trouble free operation will assure you a dependable supply of air power on demand.

Check industrialgold.com for most up to date manual and compressor service and technical information

CAUTION: Read this manual carefully before operating or servicing this air compressor, to familiarize yourself with the proper safety, operation, and standard operating procedures of this unit. **FAILURE TO COMPLY WITH INSTRUCTIONS IN THIS MANUAL COULD RESULT IN THE VOIDING OF YOUR WARRANTY, AND PERSONAL INJURY, AND/OR PROPERTY DAMAGE. THE MANUFACTURER OF THIS AIR COMPRESSOR WILL NOT BE LIABLE FOR ANY DAMAGE BECAUSE OF FAILURE TO FOLLOW THE INSTRUCTIONS IN THIS MANUAL.** By following the instructions and recommendations in this manual you will ensure a longer and safer service life of your air compressor.

NOTICE: All air compressors must be installed by a qualified and trained technician. If you need a qualified technician, call 800-531-9656 or 972-352-6304. Improper installation may result in damage to the compressor, personal injury, and will void the warranty of the compressor package.

If you have questions or need clarification about this manual or your compressor call 800-531-9656

Do not operate compressor outdoors in wet weather

Industrial Gold

Quality Air Compressors at a Great Price.

industrialgold.com ■ 1-800-531-9656 ■ Fax 972-352-6364

© Industrial Gold



Scan to visit our website



Contents

Additional Information.....	2
Safety Precautions and Warnings.....	3

Installation

Receiving and Uncrating Your Compressor	8
Compressor Installation.....	9
Startup Preparation and Procedures.....	10

Maintenance

Stopping for Maintenance or Service	11
Maintenance Procedures.....	12
Daily	12
Weekly	12
Monthly.....	12
Every 3 Months/500 Hours	12
Elite Units	12
Long Term Storage.....	12
Maintenance Log.....	13
Adjusting Belt Tension & Pulley Alignment	14
Self Tensioning Belt Rocker Plates.....	15

Other

Troubleshooting Common Issues	16
Notes.....	19
Parts Diagrams	21
Warranty	26
Installation Sheet.....	27

Additional Information

For compressor pump information see pump specific manual.

For installation instructions see Install Guide.

For compressor package wiring diagram contact manufacturer.

For compressor parts breakdown see website (industrialgold.com) or contact compressor manufacturer.

On electric driven compressors always follow NEC (National Electric Code) and any local applicable code that exceeds NEC guidelines.

On gas/diesel engine driven packages follow engine manufacturer guide for proper placement and installation of engine driven equipment.

NOTICE: Air compressors must be installed by trained installation personnel. Installation sheets must be sent back in for warranty activation. If you need help finding a qualified technician to properly perform installation, call 800-531-9656 or 972-352-6304.

WARNING: Read all installation steps in install guide, and compressor package manual prior to uncrating or installing compressor package. Failure to do so can result in personal injury or damage to compressor package.

NOTICE: All compressor air receivers should be inspected by a certified pressure vessel technician at least once per year, to check for leaks, weak points in the metal or any other deformity of the air receiver. If at any time a receiver appears out of conformance with ASME/CRN certification or a deformity is believed to have developed, no matter how minor it may appear the tank should be locked out of service immediately and replaced with a certified ASME/CRN certified air receiver immediately before the compressor can be put back into service. The receivers should have a general inspection weekly as part of normal service.

SAFETY PRECAUTIONS AND WARNINGS

Listed are some, but not all safety precautions that must be observed with compressors and compressed air systems. Failure to follow any of these warnings may result in severe personal injury, death, property damage and/or compressor damage.

Air from this compressor will cause severe injury or death if used for breathing or food processing.

Air used for these processes must meet OSHA 29 CFR 1910 or FDA 21 178.3570 regulations.

This compressor is designed for use in the compression of normal atmospheric air only.

No other gases, vapors or fumes should be exposed to the compressor intake, nor processed through the compressor.

Disconnect all power supplies to the compressor plus any remote controllers prior to servicing the unit.

Relieve all pressure internal to the compressor prior to servicing.

Do not depend on check valves to hold system pressure.

A properly sized safety valve must be installed in the discharge piping ahead (upstream) of any shut-off valve (block valve), heat exchanger, orifice or any potential blockage point. Failure to install a safety relief valve could result in rupturing or explosion of some compressor or safety component.

Do not change the pressure setting of the safety relief valve, restrict the function of the safety relief valve, or replace the safety valve with a plug.

Over pressurization of some system or compressor component can occur, resulting in severe personal injury, death and property damage.

Never use plastic pipe, rubber hose, or soldered joints in any part of the compressed air system.

Failure to ensure system compatibility with compressor piping is dangerous.

Never use a flammable or toxic solvent for cleaning the air filter or any parts.

Do not attempt to service any parts while the compressor is operating.

Do not operate the compressor at pressures in excess of its rating.

Do not remove any guards while the compressor is operating.

Observe gauges daily to ensure compressor is operating properly.

Follow all maintenance procedures and check all safety devices on schedule.

Compressed air is dangerous, do not play with it.

Use the correct lubricant at all times.

Always wear proper safety equipment when using compressed air.

Always install compressor to all local applicable electric codes.

WARNING: Always wear proper protective eye wear, hearing protection and safety clothing when working around the compressor package. No loose or baggy clothing should be worn around compressor package at any time.

WARNING: On electric motor powered air compressors make sure electrical system is up to National Electric Code (NEC) prior to installing compressor system. Failure to install a compressor with a proper NEC electrical system can cause personal injury, compressor package damage and void compressor package warranty.

NOTICE: To ensure full compressor tank warranty all tank mounted compressor packages must be mounted on factory approved vibration isolation pads. A compressor should NEVER be installed while still on or in its original packaging. Failure to properly install the compressor system with approved vibration isolation pads will result in the compressor tank warranty being void.

WARNING: Industrial Gold compressors can operate at pressures from 0-250 PSI depending on the compressor package design and build specifications. Always verify that the system the compressor is installed into can handle the maximum operational pressure the compressor. NEVER install a compressor in a system that can not handle the compressors maximum operating pressure.

WARNING: Compressed air is extremely dangerous when not properly used or installed. Always make sure a trained compressed air professional has looked over the air system prior to use. Improper installation or use of compressed air can cause bodily injury or death. NEVER pressurize an object that was not designed to be pressurized. Pressurizing objects not properly engineered for the maximum operating pressure of the compressor system can cause bodily injury or death.

WARNING: Never apply air pressure to compressor crank case, always make sure crank case vent is clear and free from obstructions. Adding pressure to the crank case can cause serious bodily injury or death.

WARNING: Never operate a compressor in a moving vehicle or towable object in motion. Doing so can damage the compressor, compressor drive components, or auxiliary parts on the compressor package. Operating the compressor in a moving vehicle or towable object can cause serious bodily injury or death.

WARNING: Check function of safety valves, weekly to insure proper function, replace immediately if faulty or damaged.

WARNING: (Compressors Packaged with NEMA 7 Components)

Industrial Gold certifies that the electric motor, electrical enclosure and electrical conduit are rated for NEMA7/hazardous locations. (Only for applicable packages with NEMA7 added components)

Air compressors have multiple moving parts and potential points of contact that could create an ignition source. The compressor pumps are manufactured with ferrous metals and in some cases multiple moving parts can come in contact with one another causing an ignition source.

Industrial Gold does not guarantee this will not occur. Lack of maintenance or care can result in conditions that could also cause ignition sources.

Industrial Gold only guarantees that the electric motor, electrical enclosure and electrical conduit are rated for NEMA7 hazardous location. Industrial Gold accepts no other responsibility for the rating of the package.

NOISE

Noise is a potential health hazard that must be considered. There are local and federal laws specifying maximum acceptable noise levels that must not be exceeded. Most of the noise from a reciprocating compressor originates from the air inlet point. Excessive noise can be greatly reduced by installing an intake noise silencer. Intake noise silencers are available from the compressor manufacturer.

PIPING FITUP

Care must be taken to avoid assembling the piping in a strain with the compressor. It should line up without having to spring or twist into position. Adequate expansion loops or bends should be installed to prevent undue stresses at the compressor resulting from the changes between hot and cold conditions. Pipe support should be mounted independently of the compressor and anchored as necessary to limit vibration and prevent expansion strains.



DANGER

Safety valves are to protect system integrity in accordance with ASME Codes and ANSI B19.3 safety standards. Failure to use safety valves of the proper capacity and pressure will cause severe personal injury or death.

NOTE: Standard motors are open drip proof with a maximum ambient temperature rating of 104°F. They are not suitable for salt laden, corrosive, dirty, wet, or explosive environments.

SAFETY VALVES: Safety valves are pressure relief valves and should be sized and purchased with a pressure setting to protect the weakest link in the system. Never change the pressure setting, only the safety valve manufacturer is qualified to make a change. Safety valves are to be placed ahead of any potential blockage point which includes but is not limited to, shutoff valves, heat exchangers, pulsation dampeners, and discharge silencers.



CAUTION

Failure to properly size, set and install pressure relief valves can be fatal.

Removal or painting over safety labels will result in uninformed conditions. This may result in personal injury or property damage. Warnings signs and labels must be provided with enough light to read, conspicuously located and maintained for legibility. Do not remove any warning, caution, or instructional material attached.

Provisions should be made to have the instruction manual readily available to the operator and maintenance personnel. If for any reason any part of the manual becomes illegible or if the manual is lost, have it replaced immediately. The instruction manual should be periodically read to refresh one's memory, it may prevent a serious or fatal accident.

NOTICE: Air compressors must be installed by trained installation personnel. Installation sheets must be sent back in for warranty activation. If you need help finding a qualified technician to properly perform installation, call 800-531-9656 or 972-352-6304.

	<p>ASME coded pressure vessels must not be modified, welded, repaired, reworked or subjected to operation conditions outside the nameplate ratings. Such actions will negate code status, effect insurance status and may cause severe personal injury, death, and property damage.</p>
--	--

PRESSURE VESSELS

Air receiver tanks and other pressure containing vessels such as, but not limited to, pulsation bottles, heat exchangers, moisture separators and traps, must be in accordance with ASME Boiler and Pressure Vessel Code Section VIII and ANSI B19.3 Safety Standards.

	<p>Relieve compressor and system air pressure by opening the appropriate manual relief valve prior to servicing.</p> <p>Failure to relieve all system pressure may result in severe personal injury, death and property damage.</p>
--	---

MANUAL RELIEF AND SHUTOFF VALVES

Install a manual relief valve to vent the compressor to atmosphere. In those instances where the air receiver tank services a single compressor, the manual relief valve can be installed on the receiver. When a manual shut-off valve, and a safety relief valve installed upstream from the manual relief valve. These valves are to be designed and installed as to permit maintenance to be performed in a safe manner. Never substitute a check valve for a manual shut-off valve (block valve) if the purpose is to isolate the compressor from a system for servicing.

	<p>Guards must be fastened in place before starting the compressor and never removed before cutting off and locking out the main power supply.</p>
--	---

GUARDS

All mechanical action or motion is hazardous in varying degrees and needs to be guarded.

Guarding must be in compliance with OSHA Safety and Health Standards 29 CFR 1910.219 in OSHA manual 2206 and any state or local code.

	<p>Excessive speed of the compressor or driver can be lethal. Never operate the compressor beyond the manufacturer's recommendation.</p> <p>Bursting of the flywheel may be the greatest threat because the normal guard may not contain all the pieces.</p> <p>Crankshaft and connecting rod breakage is a possibility and compressor efficiency, valve life and bearing life will be abnormally reduced.</p>
--	---

DRIVES

It is important that the compressor and motor pulleys are aligned properly and the V belt is correctly tensioned. Improper pulley alignment and belt tension are causes for motor overloading, excessive vibration, and premature belt and/or bearing failure.



CAUTION

Generator System Information



CAUTION

Always allow generator to reach operating speed before connecting load.

Always contact the factory before performing repairs.

Never overload the generator. Overloading can and will damage generator.

Never fuel engine while generator is running or plugged in.

The generator is an electrical device and should never be operated in rainy or damp conditions, Severe Electrocutation can occur causing severe injury or death.

Never plug in frayed, damaged, exposed or broken wires, or cords to generator. Severe electrical shock can occur.

Only plug in approved UL, CSA or ETL devices.

If the generator or package appears to be damaged do not operate and contact the manufacturer for assistance.

Do not modify or change the generator from its original state. Doing so can cause serious injury and void warranty.

NOTICE: Air compressors must be installed by trained installation personnel. Installation sheets must be sent back in for warranty activation. If you need help finding a qualified technician to properly perform installation, call 800-531-9656 or 972-352-6304.

Receiving and Uncrating of your Compressor

BEFORE UNCRATING THE COMPRESSOR THE FOLLOWING STEPS SHOULD BE TAKEN.

1. Immediately upon receipt of the equipment, it should be inspected for damage that may have occurred during shipment. If any damage is found, demand an inspection immediately by an inspector from the carrier. Ask them how to file a claim for damages.
2. Insure that adequate lifting equipment is available for moving the machinery. Never attempt to move compressor without proper lifting equipment.
3. Read the compressor nameplate to be sure the compressor is the model and size ordered.
4. Read the motor nameplate to be sure the motor is compatible with your conditions.

NOTE: Standard motors are open drip proof with a maximum ambient temperature rating of 104°F. They are not suitable for salt laden, corrosive, dirty, wet, or explosive environments.



CAUTION

Improper lifting can result in component or system damage or personal injury.

Follow good shop practices and safety procedures.



CAUTION

Under no circumstances should a compressor be placed in an area that may be exposed to a flammable, toxic, volatile or corrosive atmosphere nor should flammable, toxic, volatile or corrosive agents be stored near the compressor.

NOTICE: Air compressors must be installed by trained installation personnel. Installation sheets must be sent back in for warranty activation. If you need help finding a qualified technician to properly perform installation, call 800-531-9656 or 972-352-6304.

Compressor Installation

LOCATION

Locate the compressor in an indoor area that is clean, dry, well lit, and well ventilated, with sufficient space for safe and proper inspection and maintenance. Ambient temperatures should not exceed 104°F or fall below 30°F unless an electric motor rated for a higher temperature is used. Inspection and maintenance checks are required daily, therefore, ample space is required around the compressor.

The compressor must not be installed closer than 18 inches from a wall or from another compressor to allow ample circulation of air across the compressor cylinders and head, and through the coolers if they are part of the system. Additional safety can be achieved by locating the pulley guard next to the wall.

MOUNTING

The use of the factory supplied rubber vibration isolation pads, or other factory supplied vibration isolation mounting equipment is required for tank warranty from the original tank manufacturer. The compressor should never be left on original shipping material for installation. If a shim is required to level the unit, place it between the pad and floor. If you bolt the unit to the floor, use the bolts as guide pins and do not tighten the bolts. The rubber pads are used to absorb machine vibration and cannot work effectively if bolted tightly.

INDUCTION SYSTEM

Do not locate the compressor where it could ingest or ignite toxic, explosive or corrosive vapors, ambient air temperatures exceeding 110°F, water, or extremely dirty air. Ingestion of any of the above noted atmospheres by the compressor could jeopardize the performance of the equipment and all personnel exposed to the total compressed air system.

Destructive pulsations can be induced by reciprocating compressors that will damage walls and break windows. Pulsation can be minimized by adding a pulsation dampener on the inlet side of the compressor.

For compressor tank to have full manufacturer warranty. The tank must be installed properly on manufacturer supplied vibration pads per compressor manual. Failure to do so can void compressor tank warranty and cause tank cracks or failures.

On Electric compressors all electrical connections must be wired and installed per NEC (National Electric Code) (See the back of the manual for NEC code) and all local applicable codes for full electric component warranty. Failure to do so can void compressor electrical warranty.

Start Up Preparation & Procedures

The following check list shall be adhered to before putting the compressor into operation.

FAILURE TO PERFORM THE CHECKS MAY RESULT IN SERIOUS INJURY OR DEATH, PROPERTY DAMAGE AND/OR MECHANICAL FAILURE.

DISCONNECT AND LOCK OUT POWER/FUEL SUPPLY.

1. Remove all loose pieces and tools around the compressor installation.
2. Check oil level in crankcase, add as necessary.
3. Check all pressure connections for tightness and leaks.
4. Check to make sure all safety relief valves are in place and operational.
5. Check to be sure all guards are in place and securely mounted.
6. Check fuses, circuit breakers and thermal overloads for proper size.
7. Open all manual shut-off valves (block valves) at and beyond the compressor discharge.

The following procedures should be followed for start-up of a new installation, or after changes have been made to an existing installation, and/or after service repair work has been performed.

1. Instructions in addition to those contained within this manual, supplied by manufacturers of supporting equipment, must also be read and understood before start-up.
2. Check oil level in crankcase.
3. Drain moisture from air receiver and traps.
4. Start compressor and watch for excessive vibration or strange noises.
If either is observed, stop the compressor immediately and correct.
5. Check air receiver or system pressure.
6. Manually activated safety relief valves by pulling ring or lever.
7. Check operation of controls.
8. Run the compressor for one half hour, unloaded and change the oil after the first 8 hours of use.
9. After two days of operation check belt tension, air piping for leaks, and crankcase oil level.

NOTICE: Air compressors must be installed by trained installation personnel. Installation sheets must be sent back in for warranty activation. If you need help finding a qualified technician to properly perform installation, call 800-531-9656 or 972-352-6304.

Stopping for Maintenance or Service



Never assume the compressor is ready for maintenance or service because it is stopped.

The automatic stop-start control may start the compressor at any time!

THE FOLLOWING PROCEDURE SHOULD BE FOLLOWED TO MAXIMIZE SAFETY WHEN PREPARING FOR MAINTENANCE OR SERVICE.

1. Turn compressor drive engine key switch off and remove key from compressor.
2. Close shut-off valve (block valve) between receiver and compressor, or receiver and
3. air system, to prevent any back-up of air flow into the area to be serviced.
4. Disconnect battery connection to compressor drive engine
5. Lock open manual vent valve and wait for the pressure in the area to be serviced (compressor, receiver, etc.) to be completely relieved before starting service. The Manual vent valve may be the drain valve in the receiver. NEVER remove a plug to relieve the pressure.
6. Open all manual drain valves within the area to be serviced.
7. Wait for the unit to cool before starting service, (temperatures at 125 degrees F can burn the skin), some surface temperatures exceed 400 degrees F when the compressor is working).
8. Clean up all oils spills immediately to prevent slipping. (Mark spill area accordingly.)

Common Maintenance Parts

CA1(U) PUMP	Part Number
Reciprocating Pump Oil	IAT-30100
Air Filter Element	IAT-CA-712114
Air Filter Housing	IAT-CA-712140

CA2(U) PUMP	Part Number
Reciprocating Pump Oil	IAT-30100
Air Filter Element	IAT-CA-712114
Air Filter Housing	IAT-CA-712140

CA3 PUMP	Part Number
Reciprocating Pump Oil	IAT-30100
Air Filter Element	IAT-CA-712114
Air Filter Housing	IAT-CA-712140

PUMP OIL CAPACITIES	Quarts
CA1(U)	2.5
CA2(U)	3.5
CA3	5.5
HV30	8
LH4	2
LH3	2
LH2	1
LH1	1

Maintenance Procedures Review

DAILY:

- Drain the receiver - condensation will accumulate in the tank daily, and should be drained at least once a day. This is done to reduce corrossions of the tank from the inside. Always wear protective eye wear when draining the tank.
- Check pump oil level - For the units that have a sight glass the oil level, non running units should be no lower than the ½ way on the sight glass. If it is lower then the ½ way, add oil until it is at least ½ way up the sight glass.
- Check unit for any unusual noise or vibrations.

WEEKLY:

- Clean air filter- this will ensure that no dirt or heavy particulate makes its way into the compressors valve assemblies.
- Clean external parts of compressor and electric motor - this helps to ensure proper cooling and prevents rust and corrosion on critical parts.
- Check safety valves - this is don't to ensure they are not stuck in place and operating properly.
- **Elite Units-** Check auto tank drain for proper function

MONTHLY:

- Inspect complete air system for leaks - this is done to make sure the compressor does not get out of its duty cycle due to air leak in the system.
- Inspect oil for contamination - this is done to ensure that harmful deposits do not build up in the oil.
- Check belt tension - this is done to ensure the belt do not fail pre-maturely, tighten them as needed to ensure they do not slip. If belts are loose, tighten per instructions on next page. Failure to tighten can cause pre-mature belt failure.

EVERY 3 MONTHS OR 500 HOURS:

(WHICHEVER COMES FIRST)

- Change oil - this is done to ensure that the compressor is adequately lubricated and that the oil in the machine does not deteriorate past factory specifications.
- Inspect valve assemblies - this is done to prevent premature failure and clean out and carbon that can form in older valves.

- **Elite Units** - Clean auto tank drain strainer and check for proper function.
- Inspect pressure switch for proper function.
- Inspect check valve for proper function and remove any carbon accumulation to prevent premature failure.
- *Clean belt guard coolers (if equipped).

LONG TERM STORAGE PROCEDURES:

(COMPRESSORS THAT WILL NOT BE USED FOR 60 DAYS OR MORE)

1. **Electric Powered Units-** Turn off power and disconnect power from main compressor disconnect panel.
Gas/Diesel/Natural Gas Powered Units- Drain any fuel from package/disconnect any fuel source from system.
2. Drain compressor oil and change filters, refill oil. If engine driven drain engine oil, change filters, refill with oil.
3. Check compressor intake for debris, clean out if needed (Cover compressor intake to prevent debris, insects, etc. from entering compressor intake).
4. Clean off compressor package.
5. Drain all moisture from air compressor tank.
6. Cover compressor to prevent debris from collecting on compressor and store in a location out of direct sunlight/rain/weather. Do not seal compressor cover as moisture may form and prematurely rust parts due to humidity not being able to escape.
7. If storage last 90 days or more every 30 days manually rotate compressor pump/airend 1/4 turn.
8. Before putting compressor back into operation drain oil, change all filters, and check belt tension if belt driven. If compressor stored longer than 120 days inspect compressor intake and discharge valves on reciprocating, intake and MPV valve on rotary screws. If reciprocating check compressor check valve for operation.
9. Follow install guide and proper start up procedures prior to putting air compressor back into service. (Fill out a new compressor install data sheet at time of re-installation or initial installation).

NOTE: Maintaining proper oil level and performing oil changes at proper intervals is necessary for the proper function of the air compressor system. The best oil for you air compressor is **CAS30100 full synthetic reciprocating compressor oil.**

Reciprocating Compressor Maintenance Log

MAINTENANCE TO BE PERFORMED EVERY 3 MONTHS OR 500 HOURS (WHICHEVER COMES FIRST)

DATE PUT INTO SERVICE:								
SERVICE INTERVALS	TECH'S INITIALS	DATE	CHANGE		INSPECT		CLEAN	
			OIL IAT-30100	AIR FILTER	VALVES	PRESSURE SWITCH	TANK DRAIN	AIR COOLER IF EQUIPPED
Q1								
Q2								
Q3								
Q4								
Q5								
Q6								
Q7								
Q8								
Q9								
Q10								
Q11								
Q12								
Q13								
Q14								
Q15								
Q16								

- Service intervals are based on operating no more than 5 days per week 8 hours per day at 50% duty cycle.
- Increase frequency if operated more than above recommendations.
- Refer to owners manual prior to performing maintenance and for service item part numbers.
- Failure to perform recommended maintenance may cause damage to compressor and void warranty.

Adjusting Belt Tension

Proper belt tension and pulley alignment must be maintained for maximum drive efficiency and for maximum belt life. The correct tension exists if a deflection of 1/2 inch occurs by placing 10lbs of force midway between the motor pulley and the compressor flywheel. This deflection can be adjusted by the following procedure. The pulley should be carefully aligned with the flywheel and set screws should be kept tight.

1. Remove the belt guard
2. Loosen the motor mounting bolts
3. Shift the motor to the point where the correct deflection exists
4. Retighten the motor mounting belts
5. Check to ensure that the tension remain correct after tightening
6. Re-install the belt guard. All moving parts must be guarded

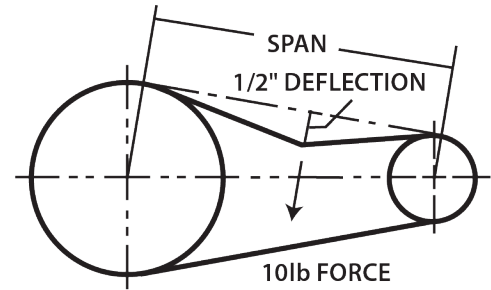

NOTE: Drive belt tension and pulley alignment are done at the same time. They are discussed separately for clarity.

Pulley Alignment

The figure to the side shows 3 examples of misaligned pulleys. To check pulley alignment, remove the belt guard and place a straightedge against the compressor flywheel, measure and record the distance from the straightedge to the edge of the drive belt. Then measure the distance to the edge of the drive belt on the motor pulley at the same edge. As long as both points measure the same distance the pulleys will be aligned if not you will need to move the pulley until its in alignment this may take a few tries. To re-align the pulley follow the steps below

1. Loosen the motor mounting bolts
2. Remove the belt guard
3. Loosen the set screw on the motor pulley
4. Align the motor pulley with the compressor flywheel
5. Re-tighten the motor pulley set screws
6. Adjust the proper belt tension
7. Re-tighten the motor mounting bolts
8. Re-install the belt guard

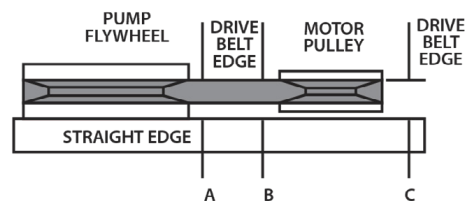
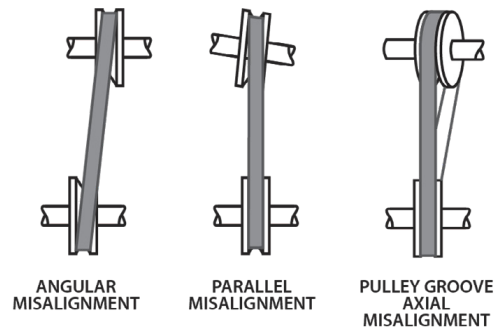

NOTICE: Air compressors must be installed by trained installation personnel. Installation sheets must be sent back in for warranty activation. If you need help finding a qualified technician to properly perform installation, call 800-531-9656 or 972-352-6304.

Illustration A

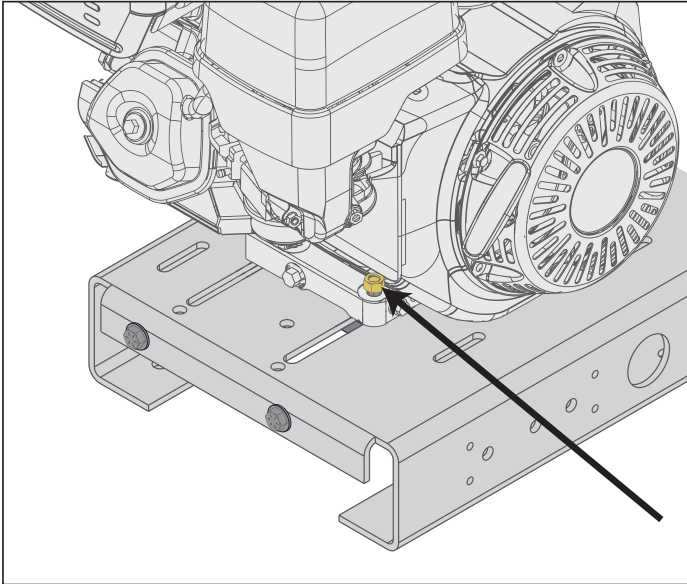
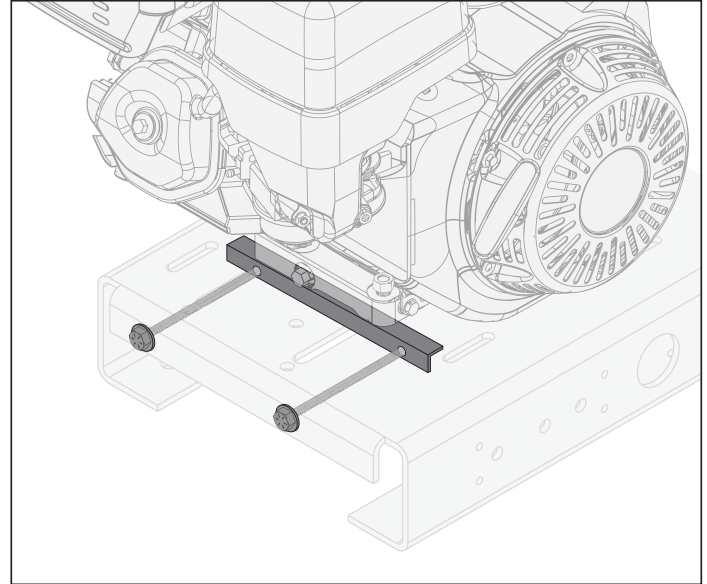

Illustration B



Belt Tensioning System for Engine Driven Units

Some engine driven units are equipped with an adjustable belt tension system. Proper belt tension is critical to performance and reliability. Follow the steps below to make adjustments:

1. Loosen the four bolts that secure the engine to the baseplate, highlighted in Illustration A. This will allow the engine to move during adjustment.
2. Use the adjustment bolts shown in Illustration B to adjust belt tension.
 - To tighten the belt, turn the bolts clockwise. To loosen, turn them counter-clockwise.
 - Alternate between the adjustment bolts. Never crank one side all at once. Turn each bolt only one full rotation at a time.
 - Continue adjusting until the belt has the proper deflection. (Refer to the Adjusting Belt Tension section of this manual for correct specifications.)
3. Once proper tension is reached, retighten the four engine mounting bolts firmly to lock the engine in position.

NOTICE: Air compressors must be installed by trained installation personnel. Installation sheets must be sent back in for warranty activation. If you need help finding a qualified technician to properly perform installation, call 800-531-9656 or 972-352-6304.

Troubleshooting Chart

NOTE: Troubleshooting problems may have similar causes and solutions

You should always contact an authorized service center before attempting to fix or repair your air compressor.

Always make sure electrical power is off before removing any inspection covers or plates or before servicing compressor.

Always make sure compressor drive engine key switch is off and removed from the compressor

Problem	Possible causes	Solutions
Compressor stalls and dies	Drive engine low on fuel Compressor check valve not functioning Compressor pilot valve not functioning Spark plug in engine bad Drive engine low on oil	Check fuel level in drive engine Inspect compressor check valve Check drive engine spark plug Check oil level on compressor drive engine Check oil on compressor pump
Compressor is running and is not compressing air	Compressor air filter is stopped up Compressor solenoid is malfunctioning Compressor intake valve is malfunctioning Compressor belts loose Compressor separator is loose	Check compressor air filter Replace compressor solenoid Check and clean compressor intake valve Check compressor belts Check compressor separator
Compressor does not idle up for compression	Throttle control valve (bullwhip) not engaging Throttle control valve cable broken Drive engine throttle linkage damaged	Check throttle control valve (bullwhip) for proper function Replace throttle control valve Check drive engine throttle linkage
Compressor air end bogs down while compressing air	Compressor belts loose Compressor pulley worn	Check belts for wear Check pulley for wear
Compressor pump knocking	Loose motor pulley or compressor flywheel Low oil level in compressor pump Carbon build up on valve and piston	Tighten pulley or flywheel Keep oil level at recommended level for proper operation Only use factory recommended oil

Troubleshooting Chart (continued)

NOTE: Troubleshooting problems may have similar causes and solutions

You should always contact an authorized service center before attempting to fix or repair your air compressor.

Always make sure electrical power is off before removing any inspection covers or plates or before servicing compressor.

Always make sure compressor drive engine key switch is off and removed from the compressor

Problem	Possible causes	Solutions
Excessive oil discharge in air (all compressors have a small amount of oil carry over in compression)	Compressor separator deteriorated Compressor runs unloaded for extended period of time Compressor scavenge line stopped up	Replace compressor separator Check unloaded time of compressor Check compressor scavenge line for blockage
Compressor overheating	Poor ventilation Dirty cooling surfaces Compressor is out of its operating duty cycle	Relocate compressor to any area with better ventilation (at least 18 inches from the nearest wall) Clean all cooling surfaces Reduce compressor duty cycle (repair leaks or add another unit to handle the excess demand)
Excessive belt wear	Pulley out of alignment Improper belt tension Pulley damaged or loose	Re-align pulley with flywheel Readjust belt tension
Compressor won't start in cold weather	Engine oil improper viscosity for temperature Control lines frozen	Check for proper viscosity for ambient temperature Move compressor to a warmer location
Compressor has excessive vibration	Compressor is not properly mounted on vibration isolation pads Compressor pulley is out of alignment Engine is low on fuel of throttle is out of adjustment	Properly mount compressor on vibration isolation pads Re-align pulleys Check drive engine oil and fuel level Readjust engine throttle control (bull whip)

Generator Troubleshooting Chart

NOTE: Troubleshooting problems may have similar causes and solutions

You should always contact an authorized service center before attempting to fix or repair your air compressor.

Always make sure electrical power is off before removing any inspection covers or plates or before servicing compressor.

Always make sure compressor drive engine key switch is off and removed from the compressor

Problem	Possible causes	Solutions
Voltage low	Engine speed too slow Generator overloaded	Replace or repair engine throttle device Reduce load on generator by unplugging components
Circuit breaker trips	Defective load connected to generator Defective receptacle Generator overloaded	Disconnect load Replace receptacle Reduce load on generator
Voltage too high	Drive engine speed too high	Reduce drive engine speed
Generator is overheating	Generator is overloaded Insufficient ventilation	Reduce load on generator Make sure adequate air flow to generator and engine
No output voltage	Defective load connected Broken or loose wire Defective receptacle Defective stator Defective rotor Defective capacitor Circuit breaker tripped	Disconnect load Have generator checked out by authorized generator technician Reset circuit breaker

13 HP LH4 Pump Parts Diagram

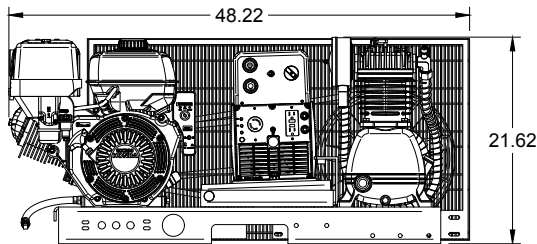
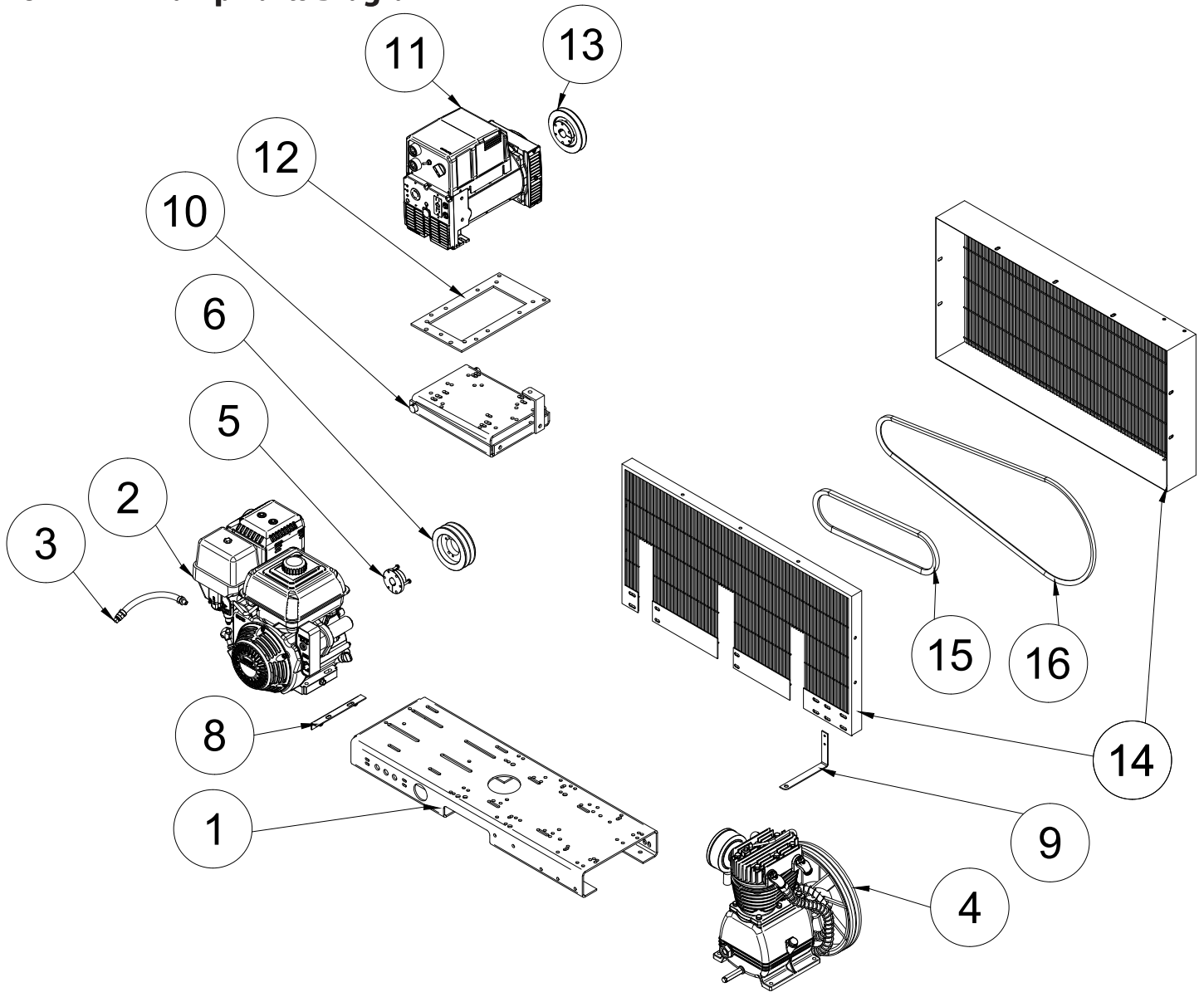

FRONT VIEW

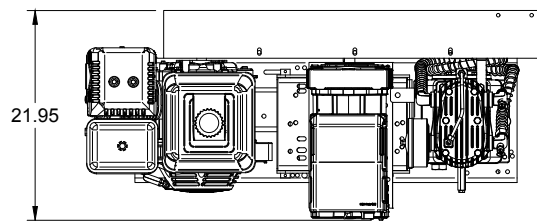

TOP VIEW

Dimensions are in inches. Part numbers may change. Depending on package figuration, parts may be different.

Item	QTY	Part Number	Description	Item	QTY	Part Number	Description
1	1	IAT-TP40BKWR	40" TOP PLATE	7	1	IAT-TCSP-H-5565-B	5.5 HP HONDA THROTTLE CONTROL
2	1	IAT-GX390K1QAE2	13HP ELE. START HONDA	8	1	IAT-MOTOR-ADJST BRKT	MOTOR ADJUSTMENT BRACKET
3	1	IAT-OIL-DRAIN	OIL DRAIN	9	1	IAT-1/8X1X12	STRAP BELT GUARD
4	1	IAT-LH4TB	5 HP BARE PUMP TWO STAGE	10	1	IAT-184-215TMP	184-215T MOTOR PLATE
5	1	IAT-LPH1HUB	1"H HUB	11	1	IAT-EW240MDC	240 AMP WELDER GENERATOR
6	1	H-2B54-S-1	PULLEY	12	1	IAT-GENWELDBRACKET-V3	NEWER GEN WELD BRACKET

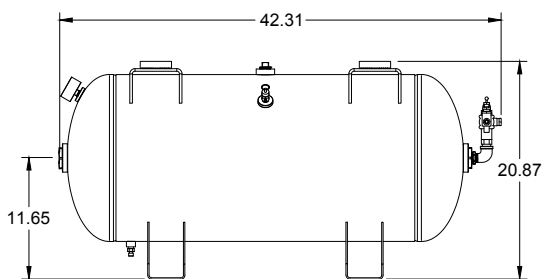
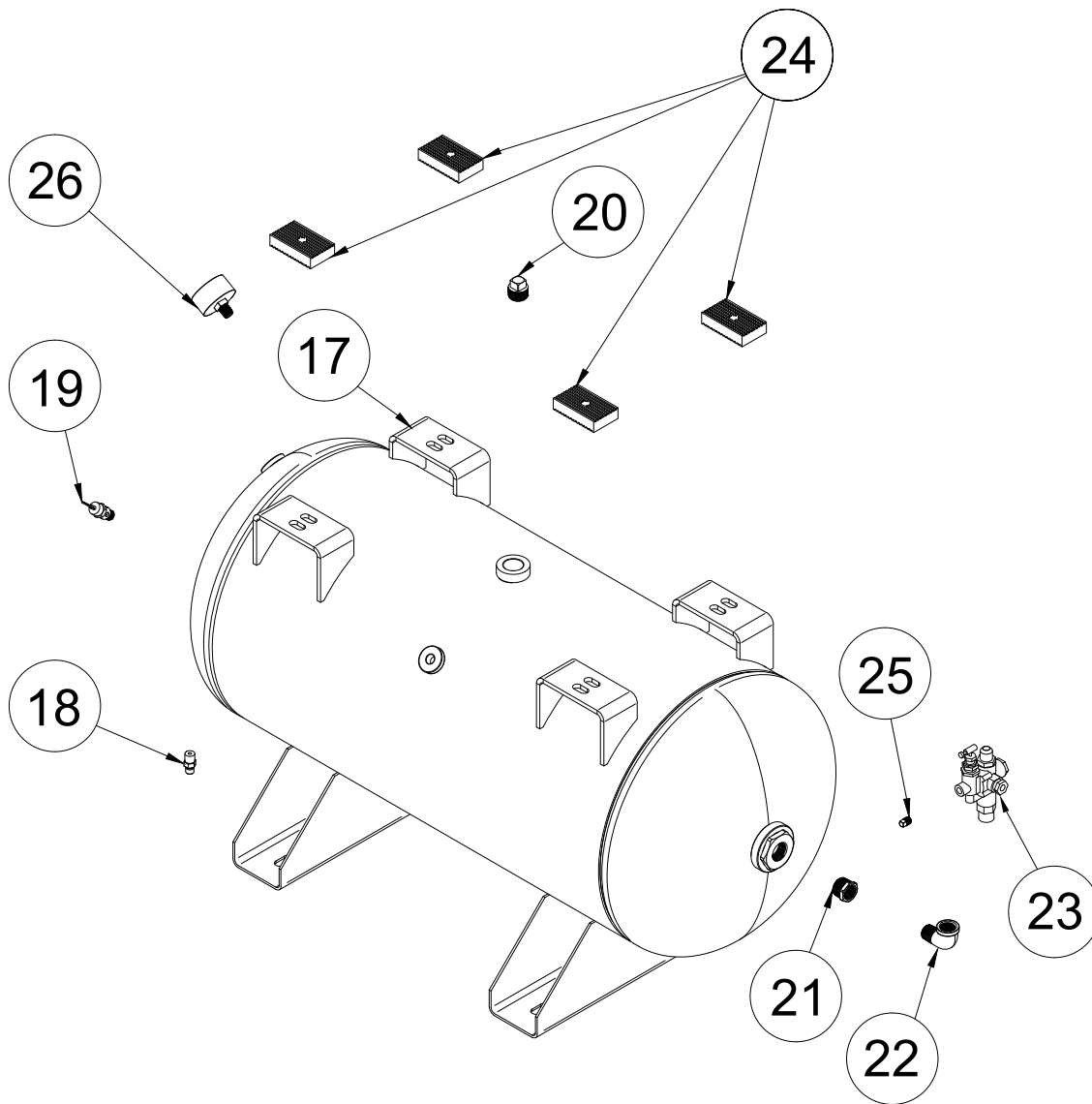

FRONT VIEW

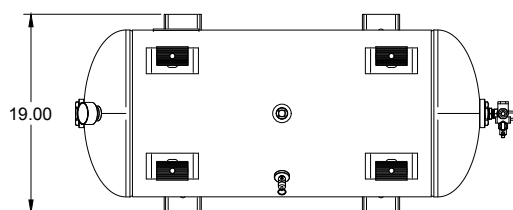

TOP VIEW

Item	QTY	Part Number	Description	Item	QTY	Part Number	Description
13	1	IAT-BK57H	PULLEY	20	1	IAT-PF3/4PLUG	3/4" PLUG
14	1	IAT-40X21X5-V1	BELTGUARDGEN/WELD #3-04	21	1	IAT-PF3/4X1/2REDUCE	3/4" X 1/2" REDUCER GALV
15	1	IAT-BX43	COGGED B BELT 43	22	1	IAT-PF1/2X90STREET	1/2" STREET 90 DEG
16	1	IAT-B82	BELT	23	1	IAT-NG-49-95-125	PILOT VALVE 95-125 1/2" JIC
17	1	IAT-30HNTP-BKWR-R4	30 GALLON TANK	24	1	IAT-3X1.8X.7D	RUBBER PAD FOR TOP PLATES
18	1	IAT-BDC604-04	1/4" PIPE DRAIN COCK	25	1	IAT-109-2	1/8" BRASS PLUG
19	1	IAT-ST25-200	SAFETY VALVE 200 PSI	26	1	IAT-PSB20	AIR GAUGE BACK MT 1/4"

13 HP CA1 Pump Parts Diagram

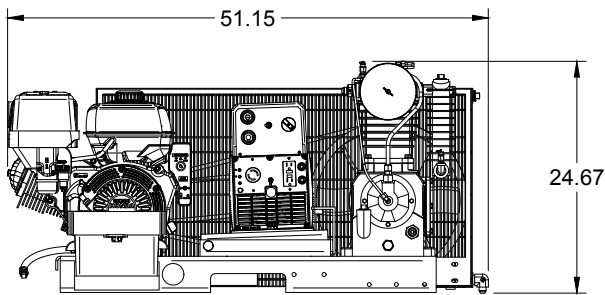
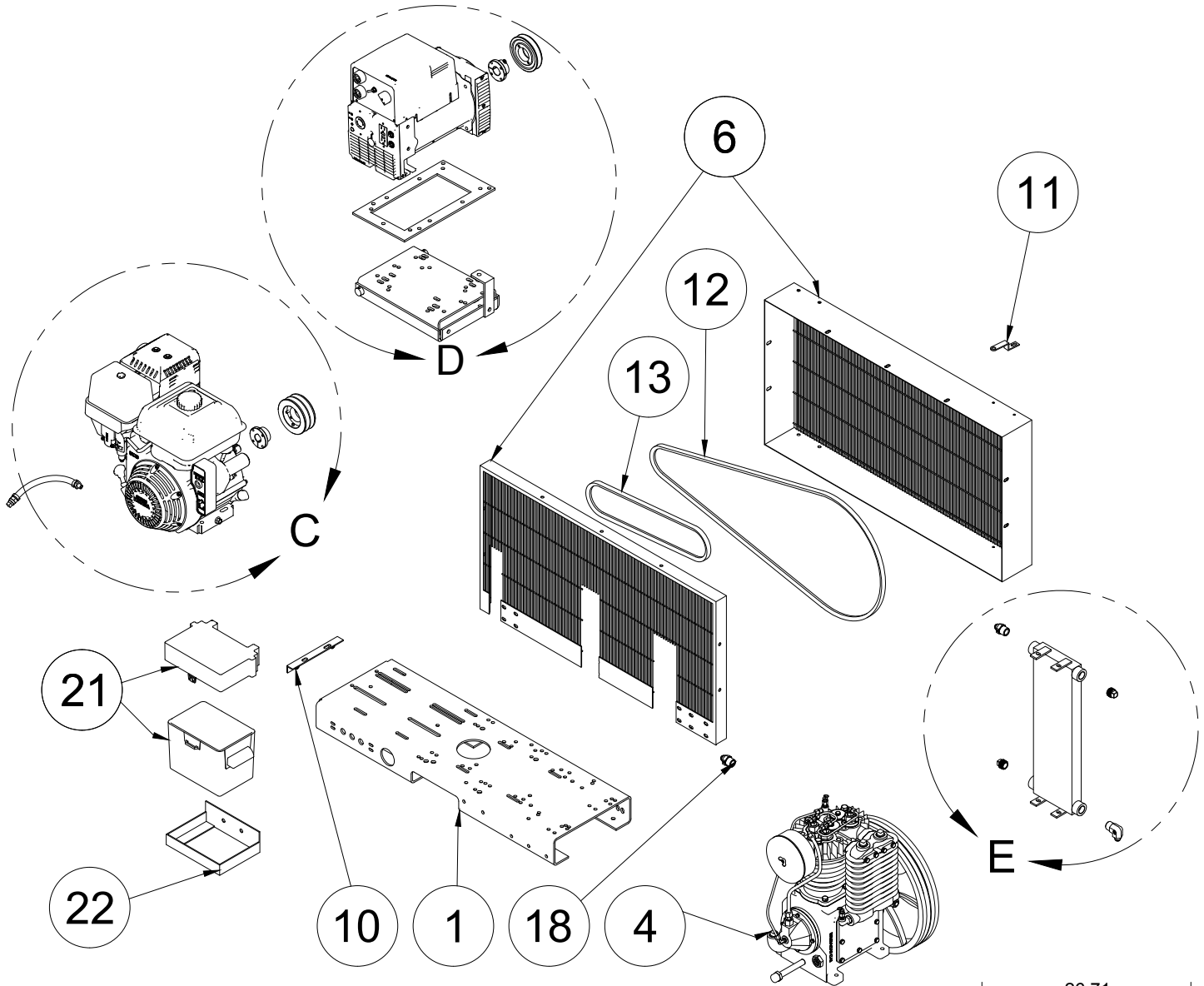

FRONT VIEW

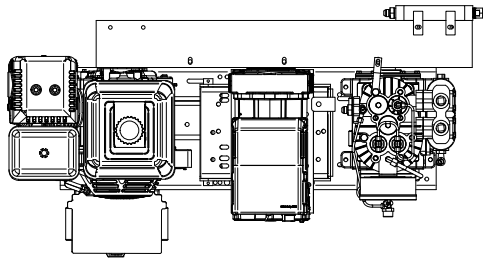

TOP VIEW

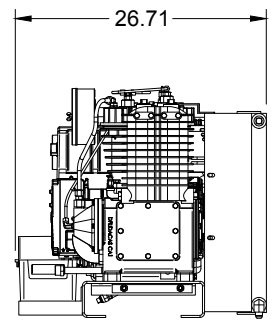

SIDE VIEW

Dimensions are in inches. Part numbers may change. Depending on package figuration, parts may be different.

Item	QTY	Part Number	Description	Item	QTY	Part Number	Description
1	1	IAT-TP40BKWR	40" TOP PLATE	7	1	IAT-GEN/WELDBRACKET1	NEWER GEN WELD BRACKET
2	1	IAT-GX390K1QAE2	13HP ELE. START HONDA	8	1	IAT-184-215TMP	184-215T MOTOR PLATE
3	1	IAT-EW240MDC	240 AMP WELDER GENERATOR	9	1	IAT-M-12-AL	BELT GUARD COOLER 48 CFM
4	1	IAT-CA1-B-U	5 HP W/CENT/UL H/U	10	1	IAT-MOTOR ADJST BRKT	MOTOR ADJUSTMENT BRACKET
5	1	IAT-OIL-DRAIN	ENGINE OIL DRAIN ASSY	11	1	IAT-BGST-CA-V3	BELT GUARD STRAP FOR CA1
6	1	IAT-BG40X21X5-V1	BELT GUARDGEN/WELD	12	1	IAT-B84	BELTS

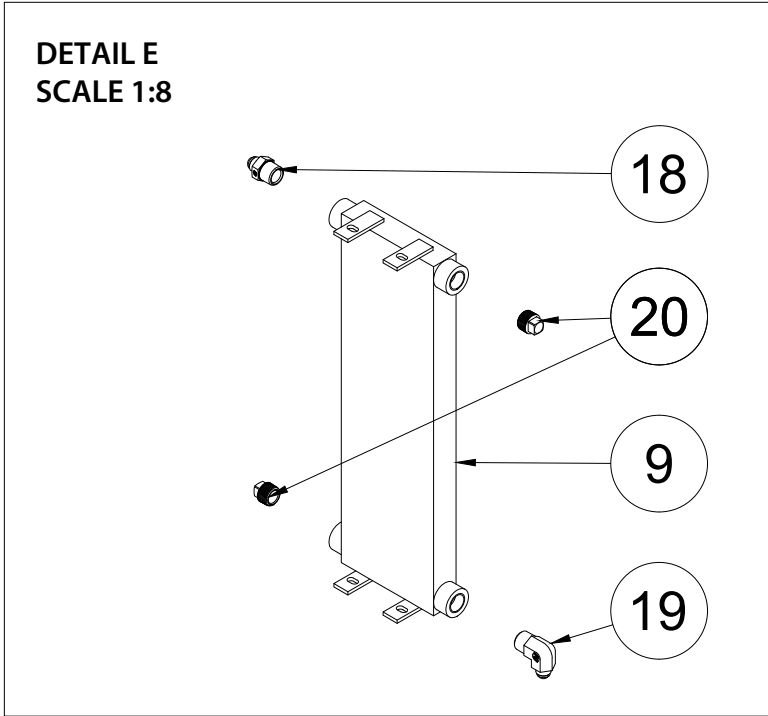
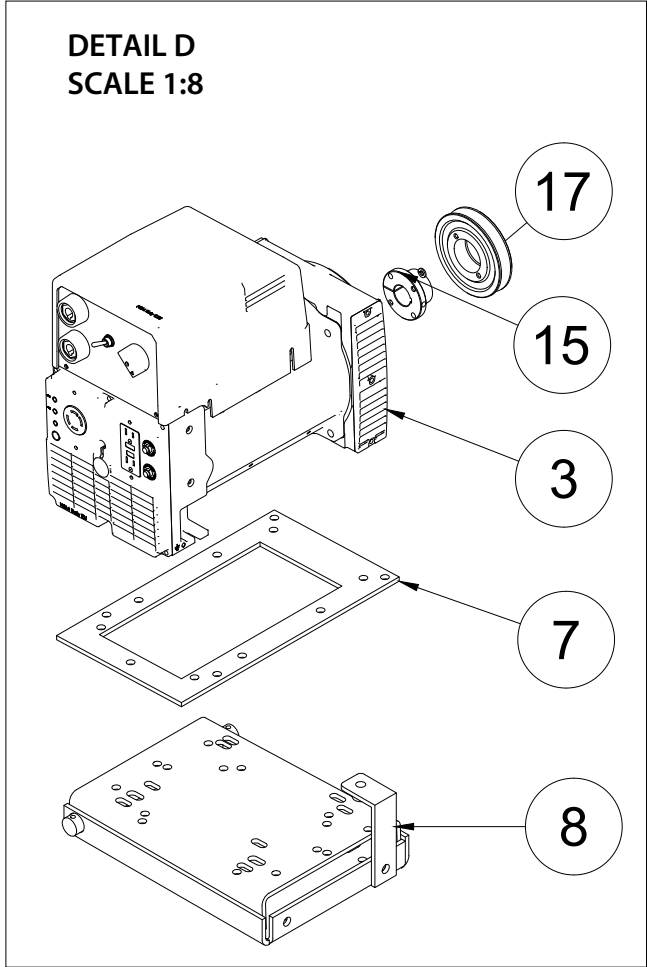
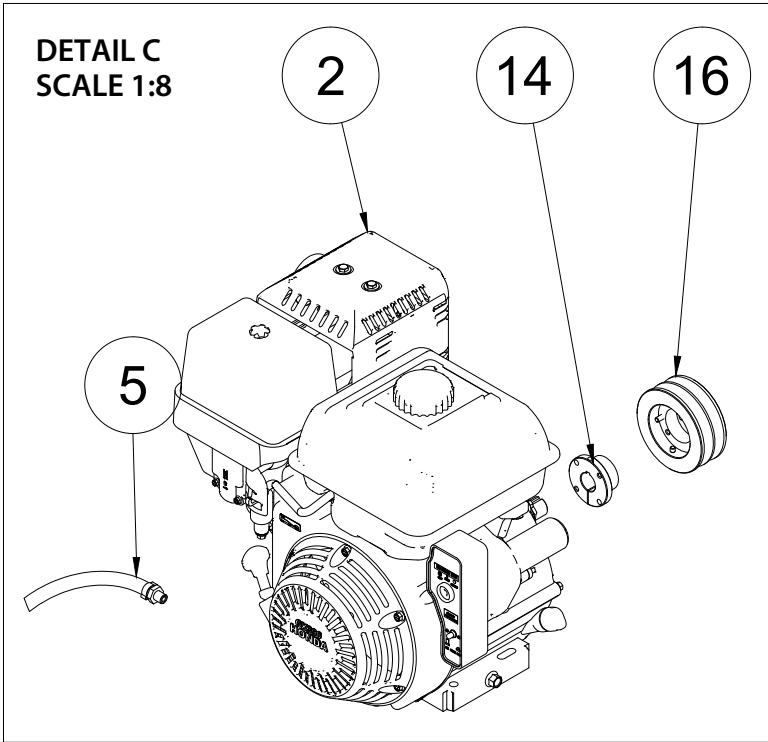

Item	QTY	Part Number	Description	Item	QTY	Part Number	Description
13	1	IAT-BX39	COGGED B BELT 43	18	2	IAT-2404-08-12-O	3/4" MP X 1/2" M JIC STRAIGHT OR
14	1	IAT-LPH1HUB	1"H HUB	19	1	IAT-2501-08-12-O	3/4" MP X 1/2" M JIC 90 DEG R IN
15	1	IAT-LX24MM	H24MM HUB	20	2	IAT-PF3/4PLUG	3/4" PLUG
16	1	IAT-LP2B445	PULLEY	21	1	IAT-BATTERY BOX SM	BATTERY BOX SMALL
17	1	IAT-MBL44	PULLEY	22	1	IAT-BATTERY PLATE	BATTERY PLATE

13 HP CA1 Pump Parts Diagram Continued

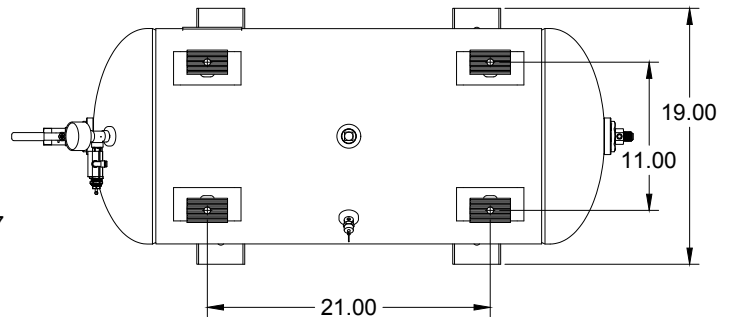
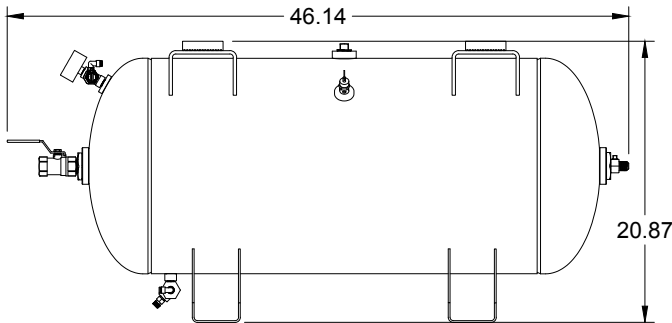
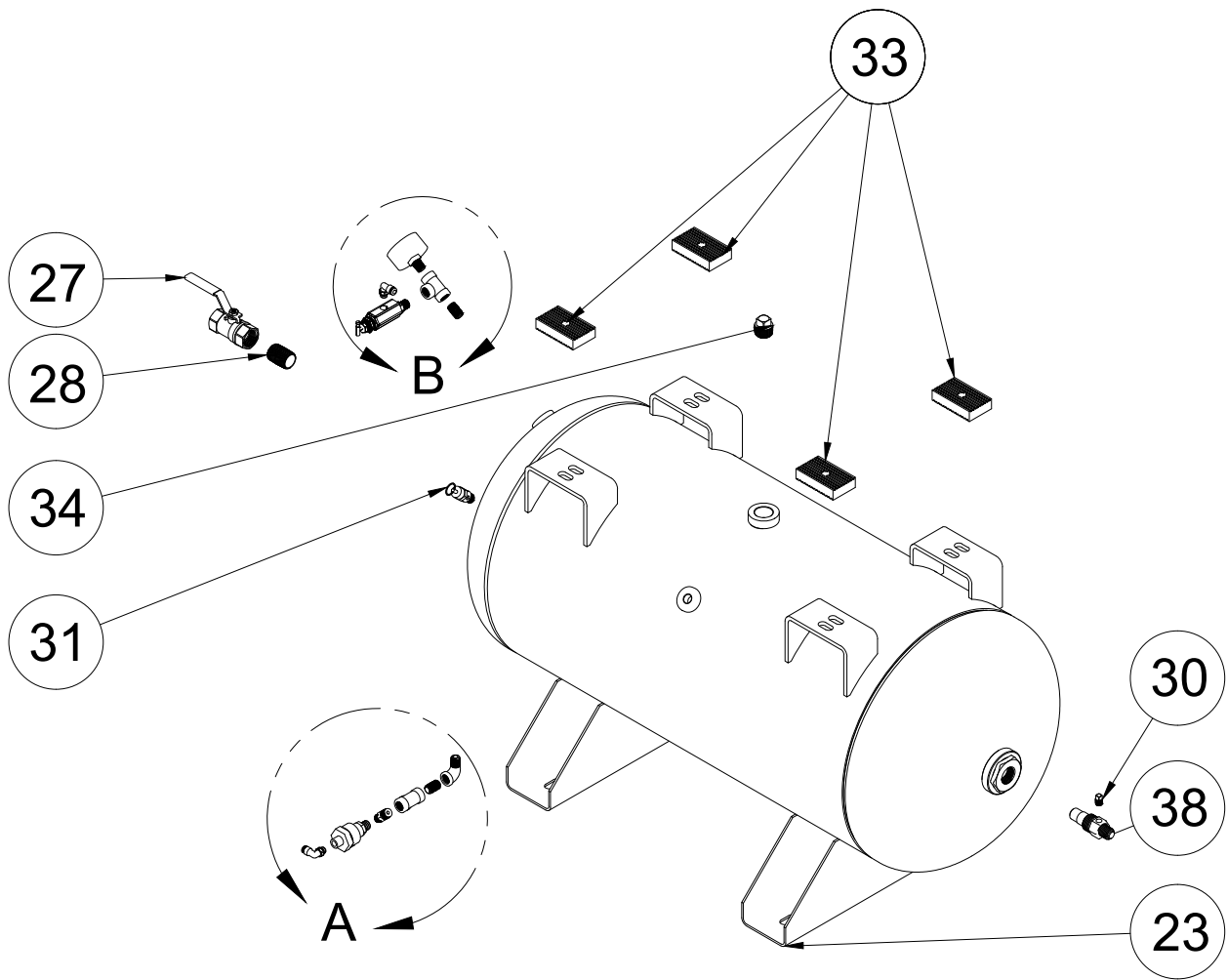

Dimensions are in inches. Part numbers may change. Depending on package figuration, parts may be different.

Item	QTY	Part Number	Description	Item	QTY	Part Number	Description
23	1	IAT-30HNTP-BKWR-R4	30 GALLON TANK	31	1	IAT-ST25-200	SAFETY VALVE 200 PSI
24	1	IAT-PF1/4" STR 90 B	1/4" STREET 90 GALV	32	1	IAT-PSB20	AIR GAUGE BACK MT 1/4"
25	2	IAT-PF1/4"CL	1/4" CLOSE NIPPLE GALV	33	4	IAT-3X1.8X.7D	RUBBER PAD FOR TOP PLATES
26	2	IAT-BPC-2501-04-02	1/8" P X 1/4" COMP PUSH LOK 90	34	1	IAT-PF3/4PLUG	3/4" PLUG
27	1	IAT-716116	BALLVALVE 3/4	35	1	IAT-RCB-MHU160/175	PILOT VALVE160/175
28	1	IAT-PF3/4"CL	3/4" CLOSE NIPPLE BL	36	1	IAT-BDC604-04	1/4" PIPE DRAIN COCK
29	2	IAT-PF1/4" T BLACK	1/4" T GALV	37	1	IAT-WV-1	AIR OPERATED AUTO TANK DRAIN
30	1	IAT-109-2	1/8" BRASS PLUG	38	1	IAT-CTJ1234	JIC CHECK VALVE

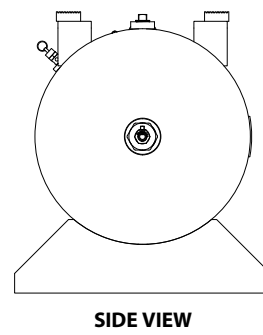
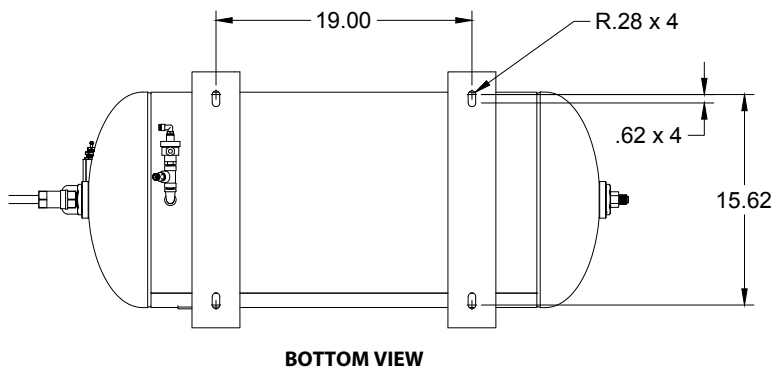
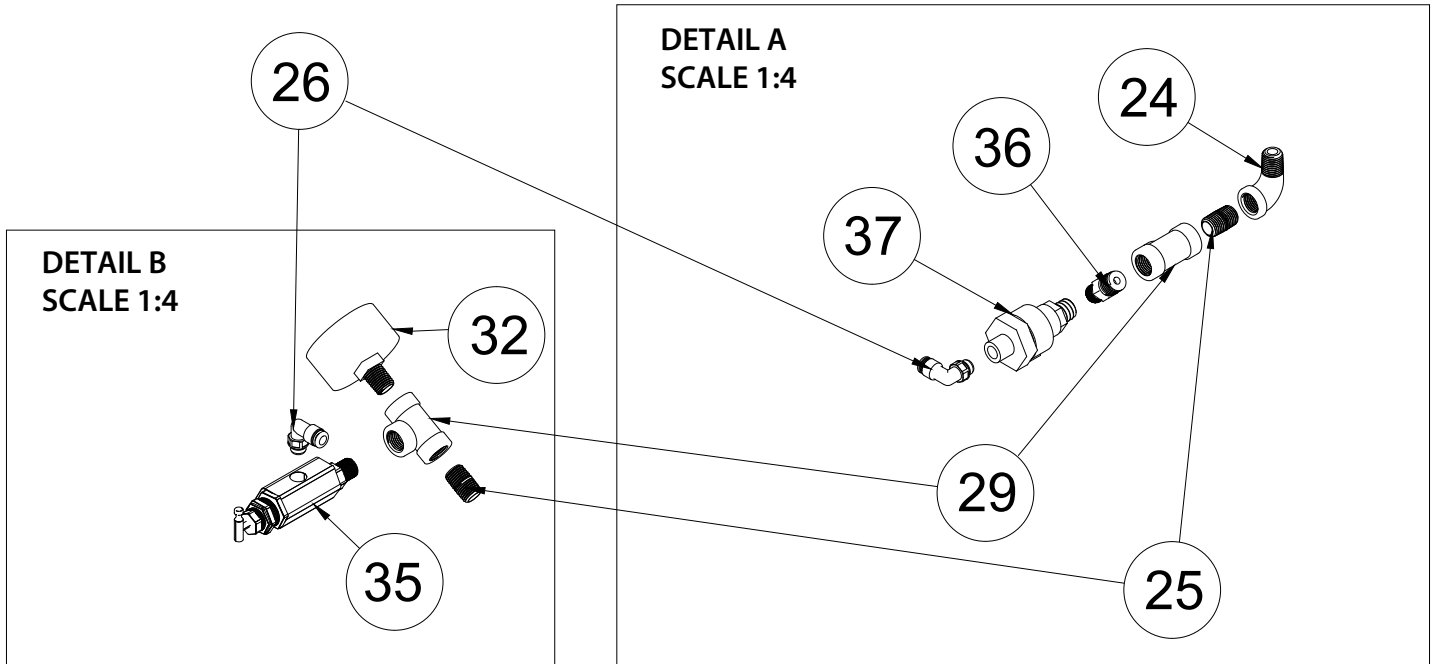

Certificate of Limited Warranty Reciprocating Compressors and Parts

All component parts on this compressor, installed by the manufacturer, are warranted to be free of defects in workmanship and material for a period of one year. Transportation charges are the responsibility of the purchaser. This warranty extends to the original purchaser of the compressor only. The purchaser must use Synthetic Reciprocating Compressor Oil, Part Number 30100, in the compressor for the duration of the compressor warranty. There are NO express warranties other than those contained in this limited warranty statement. Covered in the one year period of the warranty are defective parts and labor only. Part defects are limited to original parts only. The compressor warranty is void in the case of abuse, lack of proper service, incorrect application, incorrect installation, and neglect. Industrial Electric stationary compressors may be repaired on site as long as the compressor is not located further than 50 miles from the service center. The purchaser is responsible for any additional travel expense beyond 50 miles from the service center. Gas/Diesel Engine Driven, Single Stage Stationary, and Contractor Series compressors must be repaired at the closest service center to the compressor. The purchaser is responsible for any travel expense if they do not wish to bring the compressor to the service center. ALL "SPECIALTY COMPRESSOR" WARRANTY SERVICE MUST BE PERFORMED AT THE CLOSEST SERVICE CENTER TO THE COMPRESSOR. A "SPECIALTY COMPRESSOR" is any compressor packaged with options other than those that apply to the standard models in the catalog. Warranty labor for the first year is only covered for work performed Monday-Friday 8am-5pm excluding all major US holidays. BEFORE WARRANTY SERVICE IS PERFORMED, CONTACT THE MANUFACTURER TECH SUPPORT FOR FASTEST SOLUTION AND APPROVAL (800-531-9656 or 972-352-6304). Warranty repairs must be authorized by the manufacturer prior to work being performed. Unauthorized work may void the package warranty. The warranty claim form MUST be submitted for any potential warranty claim to be reviewed. A copy of the original invoice must be sent in with the warranty claim form.

The limited warranty is not active until the installation sheet, included with the compressor manual, is properly filled out and returned. Failure to return the installation sheet will prevent the warranty from being active.

Certificate of Limited Warranty Parts Warranty

New parts purchased are warranted to be free from defects for a period of 1 year. Parts warranty is repair or replace only. Parts warranty is limited to the repair or replacement of the defective part only. No labor allowed for parts warranty. The defective part will be repaired or replaced. Freight and labor are not covered under the parts warranty. FOR A DEFECTIVE PART, CONTACT THE WARRANTY SERVICE CENTER (800-531-9656 or 972-352-6304).

Certificate of Limited Warranty Rotary Screw Compressors

All component parts on this compressor, installed by the manufacturer, are warranted to be free of defects in workmanship and material for a period of one year. Transportation charges are the responsibility of the purchaser. This warranty extends to the original purchaser of the compressor only. The purchaser must use Synthetic Rotary Screw Oil, Part Number RS8000, in the compressor for the duration of the compressor warranty. There are NO express warranties other than those contained in this limited warranty statement. Covered in the one year period of warranty are defective parts and labor. Part defects are limited to original part only. The compressor warranty is void in the cases of abuse, lack of proper service, incorrect application, incorrect installation and neglect. Industrial Electric stationary compressors may be repaired on site as long as the compressor is not located further than 50 miles from the service center. The purchaser is responsible for any additional travel expense beyond 50 miles from the service center. Gas/Diesel Engine Driven compressors must be repaired at the closest service center to the compressor. The purchaser is responsible for any travel expense if they do not wish to bring the compressor to the service center. ALL "SPECIALTY COMPRESSOR" WARRANTY SERVICE MUST BE PERFORMED AT THE CLOSEST SERVICE CENTER TO THE COMPRESSOR. A "SPECIALTY COMPRESSOR" is any compressor packaged with options other than those that apply to the standard model in the catalog. The AIREND is covered by a 2 year warranty to be free from defects from manufacturing. This does not cover abuse, neglect, improper service, misapplication, or improper installation. An oil sample must be submitted with any AIREND warranty claim for verification. An "AIREND" is the rotors and bearings of the compressor. Warranty labor for the first year is only covered for work performed Monday-Friday 8am-5pm excluding all major US holidays. BEFORE WARRANTY SERVICE IS PERFORMED, PLEASE CONTACT MANUFACTURER TECH SUPPORT FOR FASTEST SOLUTION AND AUTHORIZATION (800-531-9656 or 972-352-6304). Warranty repairs must be authorized by the manufacturer prior to work being performed. Unauthorized work may void the package warranty. The warranty claim form MUST be submitted for any potential warranty claim to be reviewed. A copy of the original invoice must be sent in with the warranty claim form.

The limited warranty is not active until the installation sheet, included with the compressor manual, is properly filled out and returned. Failure to return the installation sheet will prevent the warranty from being active.

THIS POLICY IS LIMITED TO THE ITEMS ON THE INVOICE, WHICH IS ATTACHED WITH THIS DOCUMENT.

THIS INSTALLATION SHEET MUST BE FILLED OUT AND RETURNED FOR WARRANTY TO BEGIN

Gas/Diesel Engine Reciprocating Compressor Installation Sheet

Compressor & Installer

Compressor Model # _____ Compressor Serial # _____

Installation Company: _____ Installation Technician: _____

Technician Signature: _____ Date: _____

Drive Engine & Installation Status

Drive Engine: Gasoline Diesel Natural Gas Battery Powered

Location of Install: Truck Body (Open) Van Trailer Box Truck Other: _____

Unit Installed in Weather-Proof Enclosure: Yes No

Auxiliary Fuel Tank Needed: Yes No

Auxiliary Fuel Pump Needed: Yes No

Wiring Extension Added: Yes No

Wiring Extension Technician: _____

Performance

Max Operating Pressure: _____ PSI

Tank Drain Functional: Yes No

Checked All Air Fittings for Leaks: Yes No

Checked Unit for Oil Leaks: Yes No

Checked Belt Tension After Start-Up: Yes No

Vibration Pads Properly Installed: Yes No

Tank Fill Time: 0-125 PSI: _____ *Write N/A if pressure not applicable to unit*

0-150 PSI: _____ *Write N/A if pressure not applicable to unit*

0-175 PSI: _____ *Write N/A if pressure not applicable to unit*

All Install Steps Completed: Yes No *If No, Explain:* _____

Send a copy of this completed installation sheet to manufacturer to begin warranty.

Include the following:

- 1 image of the control panel wired up
- 1 image of the full install
- 1 image from each end of the compressor

Sales@industrialgold.com

Fax 972-352-6304

Or mail to

Industrial Gold

600 S. 2nd Ave Mansfield, TX, 76063



Industrial Gold

600 S 2nd Ave
Mansfield, TX, 76063

1-800-531-9656

Fax 972-352-6364

Quality Air Compressor at a Great Price.