

# Plato Touchscreen Duplex Reciprocating Control Panel

## Owner's Manual



Congratulations on the purchase of your new air compressor. It is precision-built from the finest materials, using state-of-the-art design and the most advanced engineering available today. Expect reliable operation, consistent performance, and air power exactly when you need it.

Check [www.industrialgold.com](http://www.industrialgold.com) for most up to date manual and compressor service and technical information

Read this manual carefully before operating or servicing this air compressor to familiarize yourself with the proper safety, operation, and standard operating procedures of this unit.

**Failure to comply with instructions in this manual could result in the voiding of your warranty, and personal injury, and/or property damage.**

The manufacturer of this air compressor will not be liable for any damage because of failure to follow the instructions in this manual.

By following the instructions and recommendations in this manual you will ensure a longer and safer service life of your air compressor.

**NOTICE: All air compressors must be installed by a qualified and trained technician.**

If you need a qualified technician, call 800-531-9656 or 972-352-6304. Improper installation may result in damage to the compressor, personal injury, and will void the warranty of the compressor package.

If you have questions or need clarification about this manual or your compressor call 800-531-9656

**Do not operate compressor outdoors in wet weather**

## Industrial Gold

**Quality Air Compressors at a Great Price.**

industrialgold.com ■ 1-800-531-9656 ■ Fax 972-352-6364

© Industrial Gold 04-2026



Scan to visit our website



## Contents

Additional Information and Warnings ..... 2

## Overview

Login Username and Password ..... 3  
Home Screen ..... 3  
Main Menu ..... 4  
Setting Up Email Reminders ..... 5

## Trouble Shooting

Transducer Error ..... 6  
Transducer Open ..... 7  
Transducer Fail ..... 8  
Contactor Stuck ..... 9  
Motor Overload ..... 10  
Oil Temperature Error ..... 11  
Air Temperature Error ..... 12  
Air Temperature Failure ..... 13  
Contact Coil Failure ..... 14  
Trouble Shooting Chart ..... 15

## Diagrams

Wiring Diagrams ..... 17

### IMPORTANT:

This manual is intended to provide instructions for operating and using the Plato Touchscreen Control Panel, not the air compressor unit itself. Compressor package comes with its own manual. Refer to owners manual for any specifications or troubleshooting issues with the air compressor. For compressor package information see specific owners manual. For compressor pump information see pump specific owners manual. For installation instructions see Install Guide.



**CAUTION**

The installation, wiring, and all electrical controls must be in accordance with ANSI C1 National Electric Code, ANSE C2 National Electric Safety Code, state and local codes. All electrical work should be performed by a qualified electrician. Failure to abide by the national, state and local codes may result in physical and/or property damage.



**Warning:** Always wear proper protective eye ware, hearing protection and safety clothing when working around the compressor package. No loose or baggy clothing should be worn around compressor package at any time.



**Notice:** Compressed Air Systems compressors can operate at pressures from 0-250 PSI depending on the compressor package design and build specifications. Always verify that the system the compressor is installed into can handle the maximum operational pressure of the compressor. NEVER install a compressor in a system that can not handle the compressors maximum operating pressure.

## Setting Adjustment Login

Username: Admin

Password: 1980

## Home Screen

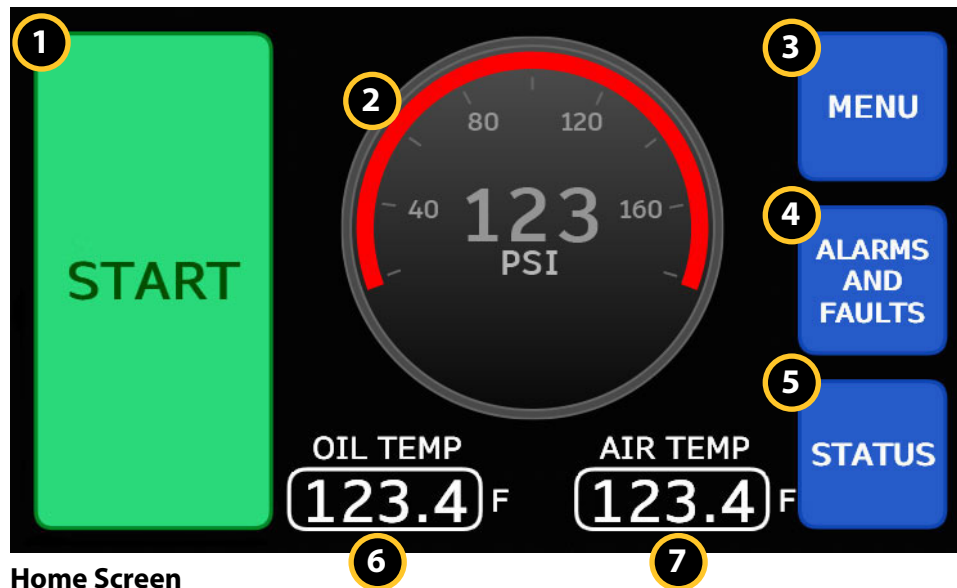

**Home Screen:** Upon powering on, the Plato Touchscreen displays the Home screen, which provides essential system information at a glance, and options for navigation.

1. **Start:** Press the Start button to initiate the compressor operation. Ensure all safety checks are completed before starting the unit.
2. **Pressure Gauge:** A digital pressure gauge that displays the current operating pressure in real time
3. **Menu:** Select the Menu button to access additional settings and configuration options for the control panel. This includes advanced machine settings, communication preferences, and more.
4. **Alarms and Faults:** Tap the Alarms and Faults button to view active and past alerts and system faults. This screen provides detailed information on any issues that require attention or maintenance.
5. **Status:** The status screen displays real-time information about the compressor's operation, including total run time, pressure, oil temperature, and air temperature.
6. **Oil Temperature Indicator:** The oil temperature indicator displays the current temperature of the compressor's oil, helping monitor proper cooling and lubrication levels for optimal performance.
7. **Air Temperature Indicator:** The air temperature indicator shows the current temperature of the compressed air output.

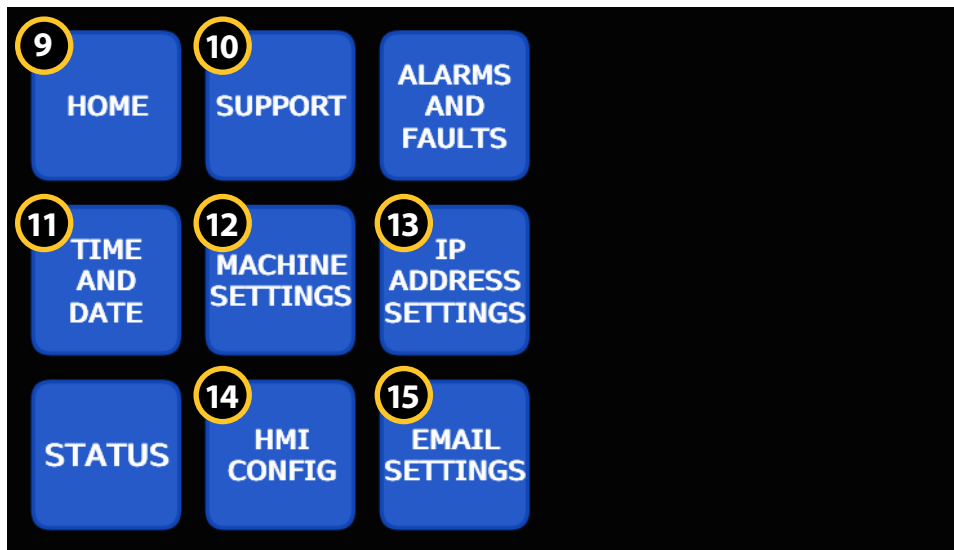

Menu

**9. Home:** Select the Home button to return to the Home screen.

**10. Support Page:** Access the Support page to view compressor model details, including the model number, serial number, and company contact details. For assistance, use the listed phone number to reach technical support directly.

**11. Time and Date:** Displays the current time and date, ensuring accurate logging of events and maintenance reminders.

**12. Machine Settings:** View system configuration options by selecting the Machine Settings button. The load/unload levels are pre-set by the manufacturer but can be modified by the user to suit specific operational needs. Other settings require manufacturer approval for modification, ensuring proper configuration and safe operation of the system.

**13. IP Address Settings:** Displays the current IP address of the Plato Touchscreen control panel. Users can connect an Ethernet cable to enable remote access to operational details, allowing for monitoring and management.

**14. HMI Config:** Provides access to configuration settings for the control panel, including options to reboot/shutdown, change the screen brightness level, and view current firmware version.

**15. Email Settings:** Open the Email Settings page to configure maintenance reminder notifications. Users can add up to three email addresses to receive alerts directly. By default, notifications are also sent to the manufacturer to assist with proactive support and maintenance tracking. **Note: Email notifications are only enabled when connected to the internet via ethernet.**

**MENU**      **HOME**

**PRESS TO SEND  
TEST EMAIL TO  
VERIFY SETTINGS**

**Service reminder return contact information.**

Email sent from:

@ Domain name:

Return phone #: (optional)

**Service reminders emails sent to the following email addresses. By default, always sent to "service-reminder@compressed-air-systems.com". Add up to 3 additional emails to send the service reminder email.**

#1 Email sent to:

@ Domain name:

#2 Email sent to:

@ Domain name:

#3 Email sent to:

@ Domain name:

### Email Settings

**Email Settings:** Open the Email Settings page to configure maintenance reminder notifications. Users can add up to three email addresses to receive alerts directly. By default, notifications are also sent to the manufacturer to assist with proactive support and maintenance tracking. **Note: Email notifications are only enabled when connected to the internet via ethernet.**

**To Enter an Email Address:** Type the first part of the email address (before the "@" ) into the field labeled "Email sent to." Then, type the second part of the email address (the domain) into the "@ Domain Name" field. Repeat for additional addresses as needed, up to a maximum of three.

**Test Email:** Located in the top right corner, this button allows users to send a test email to verify that the entered email settings are correct. Use this feature to confirm that notifications will be received as expected.

## Transducer Error



### Fault Description

This fault occurs only during initial start-up when the pressure transducer fails to detect air pressure within a set time.

- Default delay time: 5 seconds
- If no pressure is sensed in this time, the compressor will time out and shut off

## TROUBLE SHOOTING INSTRUCTIONS

### 1. Increase the Transducer Delay Time

- Power ON the compressor.
- Access the machine settings menu.
- Navigate to the “Transducer Delay Time” setting.
- Change the delay time from 5 seconds to 10 seconds.
- Confirm and save the new setting.
- Start the compressor again and check if the fault is cleared.

### 2. Check Airflow to the Transducer (if fault persists)

- Turn OFF the compressor.
- Locate the air signal line connected to the pressure transducer.
- Carefully disconnect the air signal line from the transducer.
- Ensure the open end of the air signal line is accessible and safe to check.
- Start the compressor with the line disconnected.
- Observe the disconnected tube:
  - Air is coming out:*
    - The compressor is producing air.
    - The pressure transducer may be faulty (see Step 3).
  - No air is coming out:*
    - The issue is with the compressor output, not the transducer.
    - Check for mechanical or control faults.

### 3. Test or Replace the Pressure Transducer (if needed)

- If air is present but the fault still triggers:
  - Turn OFF the compressor.
  - Disconnect and remove the pressure transducer.
- Test the transducer using a multimeter (if electrical output is available), or a calibrated pressure source to see if it responds.
- If the transducer fails the test or gives no response, replace it with a known good or new pressure transducer.
- Reconnect the air signal line and wiring.
- Start the compressor again and confirm the fault does not trigger.

## Notes:

- Always ensure power is off before disconnecting or replacing electrical components.
- If the issue persists after replacing the transducer, contact technical support or refer to the full compressor service manual.

## TROUBLE SHOOTING CHART

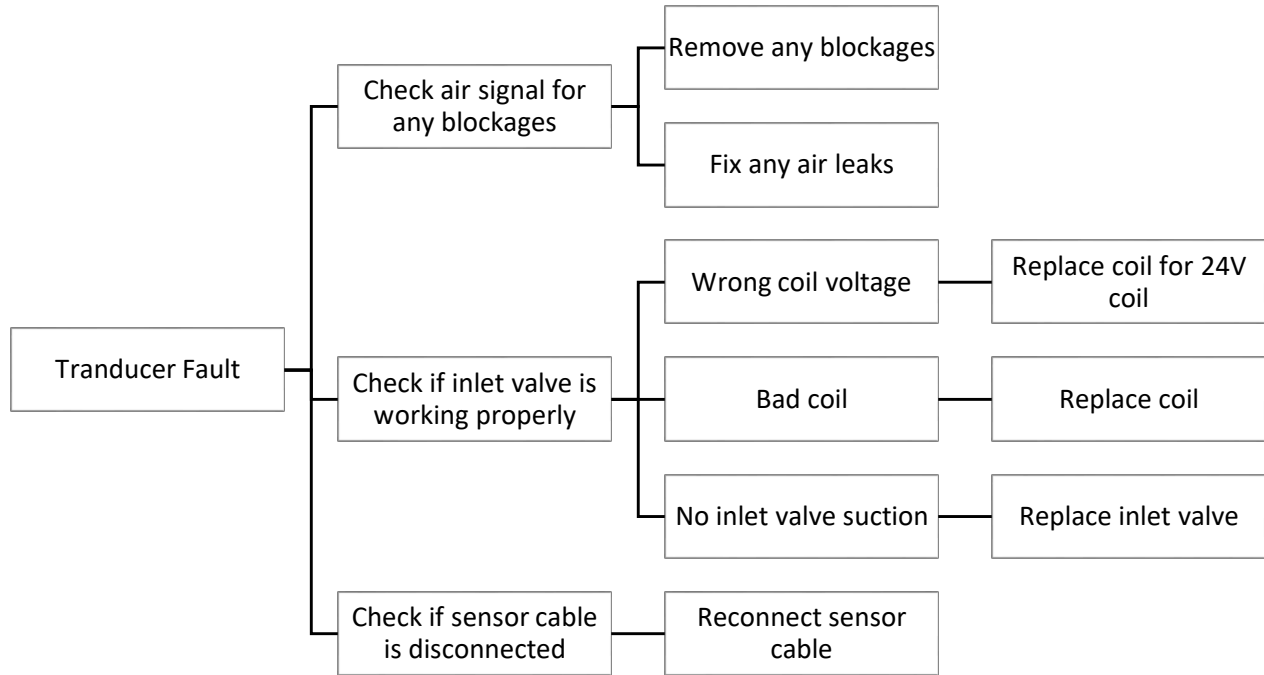

## Transducer Open



## Fault Description

This fault occurs when the PLC does not receive a signal from the pressure transducer. This typically indicates that the transducer wiring is disconnected, loose, or not making proper contact with the PLC terminals.

## TROUBLE SHOOTING INSTRUCTIONS

## 1. Power Down the System

- Turn OFF the compressor and PLC to ensure safety while inspecting wiring.

## 2. Inspect Transducer Wiring

- Visually check the wires between the pressure transducer and the PLC for any obvious damage or disconnection.

## 3. Check and Reconnect Wires

- If any wires are disconnected, reconnect them securely.
- Make sure wires are fully inserted into connectors or terminals.

#### 4. Verify PLC Terminal Connections

- Locate the PLC terminals for the pressure transducer wiring:  
AI1 (Analog Input 1)  
GND (Ground)  
24VDC (Power)
- Check each terminal for loose or poorly seated wires.
- Tighten terminal screws or reinsert wires to ensure good contact.

#### 5. Power Up and Test

- Turn ON the compressor and PLC.
- Monitor if the fault clears and if the pressure transducer signal is received by the PLC.

#### 6. Test Wiring Continuity

- If the fault persists, use a multimeter to test for:  
Continuity of each wire from transducer to PLC.  
Proper voltage supply (24VDC) at the PLC terminal.
- Replace or repair wiring if any issues are detected.

#### 7. Further Action

- If all wiring checks out and the fault remains:  
Consider testing or replacing the pressure transducer.  
Consult technical support or service manual for advanced diagnostics.

#### Notes:

- Always ensure power is off before disconnecting or replacing electrical components.
- If the issue persists after replacing the transducer, contact technical support or refer to the full compressor service manual.

### TROUBLE SHOOTING CHART

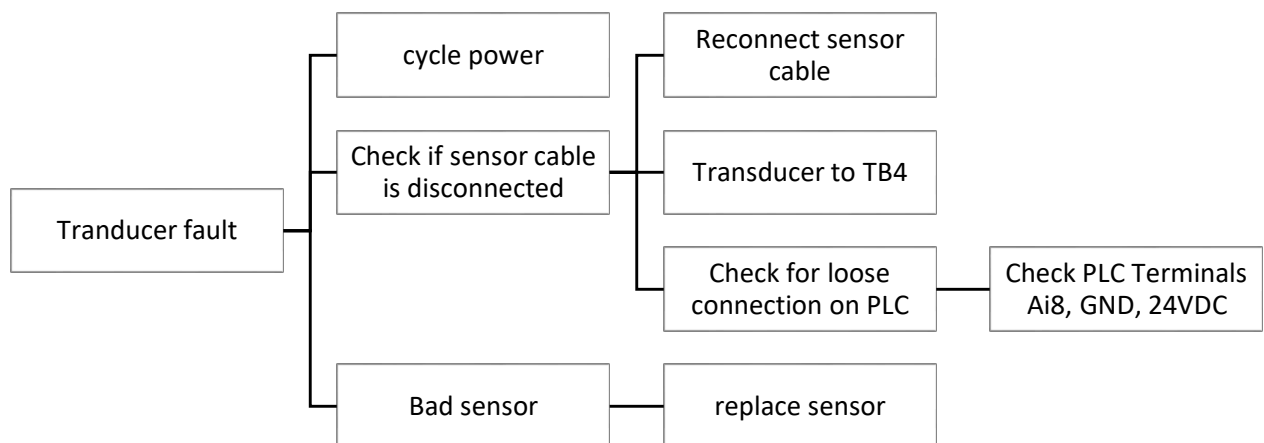

## Transducer Fail



### Fault Description

This fault occurs when the actual pressure is outside the operating range of the pressure transducer.

- The transducer range is 0–200 PSI.
- If the system pressure is below 0 PSI or above 200 PSI, this fault will be triggered.

## TROUBLE SHOOTING INSTRUCTIONS

### 1. Power Down the Unit (for Safety)

- Turn OFF the compressor before inspecting components.
- Ensure the system is depressurized if necessary.

### 2. Measure Actual System Pressure

- Connect an auxiliary pressure gauge to the system.
- Check the current pressure reading.
- Compare the reading to the transducer range: 0–200 PSI.

#### If pressure is:

- Above 200 PSI:  
Reduce system pressure using the compressor controls or manually bleed air.
- Below 0 PSI (vacuum):  
This may indicate a sensor error or a system malfunction—continue to Step 3

### 3. Inspect Pressure Transducer Cable

- Locate the pressure transducer and its cable.
- 2. Check that the cable is securely connected to the PLC or controller.
- 3. Inspect for:
  - o Loose terminals
  - o Damaged wires
  - o Corroded connectors
- 4. Reseat connectors if needed and tighten terminal screws.

### 4. Verify Compressor Unloading Operation

- Restart the unit.
- Observe if the compressor unloads when it reaches the set pressure.
- If the compressor does not unload properly:  
Access the machine settings.  
Check the unload/set pressure values to ensure they are within the 0–200 PSI range.

### 5. Confirm Settings with Manufacturer

- If the pressure and wiring are correct but the fault persists:  
Contact the factory or technical support.  
Provide them with the current machine settings for review and confirmation.

### 6. Replace the Pressure Transducer (if needed)

- The pressure transducer may be faulty if:  
Actual pressure is within range,  
Wiring is good, and  
Settings are confirmed correct,
- Replace the transducer with a new or tested unit.
- Restart the system and monitor for alarms.

### TROUBLE SHOOTING CHART

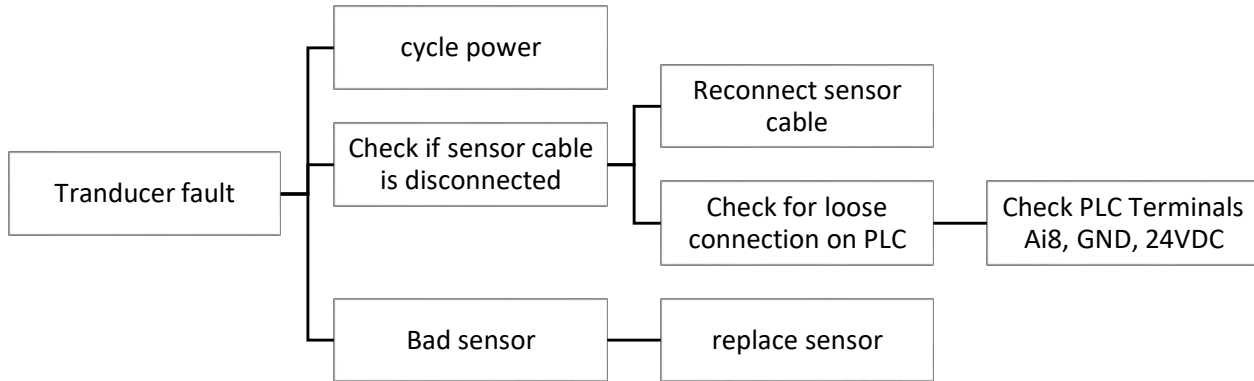

## Contactor Stuck



### Fault Description

This fault occurs when the motor contactor is engaged (closed) without receiving a command from the controller/PLC. This may indicate a stuck or welded contactor, or a wiring issue related to signal monitoring.

### TROUBLE SHOOTING INSTRUCTIONS

#### 1. Check if the Contactor is Stuck Closed

- Power down the machine completely.
- Locate the motor contactor in the control panel.
- Check if the contactor is physically stuck in the closed position.  
You may hear or feel if the contacts are welded or not springing back.

#### 2. Attempt to Unstick the Contactor

- With power still off, try to manually disengage the contactor.
- If the contactor cannot be unstuck, it is likely welded closed.  
In this case, the contactor must be replaced.

#### 3. If the Contactor is Not Engaged

- If the contactor is not stuck and appears normal, but the fault still occurs:  
Check the signal going to the PLC input AI6.
- Use a multimeter to verify if there is 24VDC present at AI6.

#### 4. Trace the 24VDC Signal

- If no 24VDC is present at Ai6:  
Refer to the wiring diagram.  
Trace the circuit from Ai6 back to the power supply.
- Check for:  
Loose or disconnected wires  
Damaged terminals  
Broken connections

#### 5. Repair and Reset

- Repair or reconnect any faulty wiring found.
- If a replacement was made (e.g. contactor), ensure all wiring is correct.
- Power the system back on.
- Test the compressor to verify normal operation.

### TROUBLE SHOOTING CHART

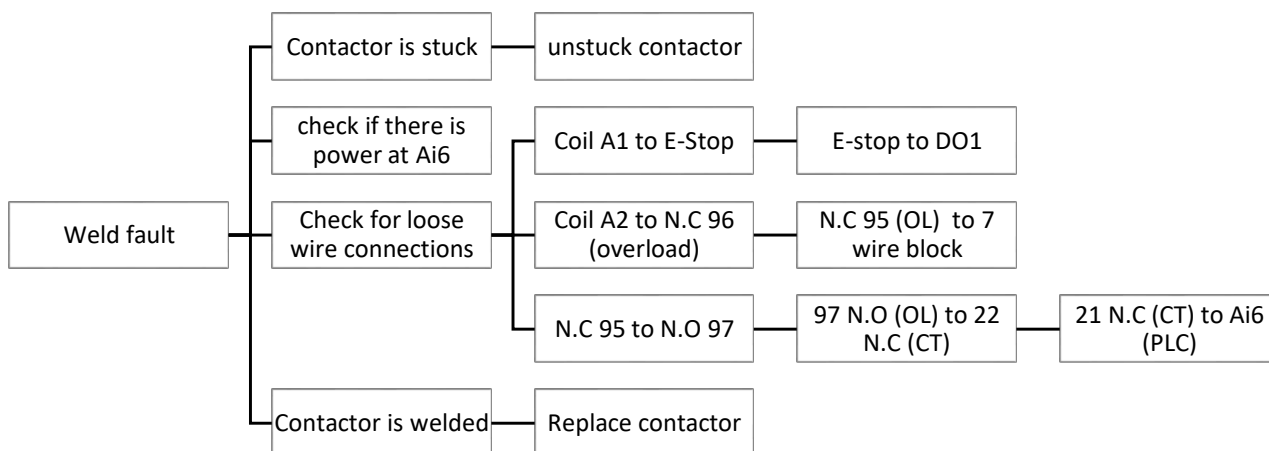

## Motor Overload

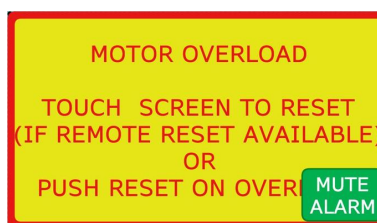

### Fault Description

This fault occurs when the motor overload relay trips due to overcurrent (excessive amperage). The overload is designed to protect the motor from overheating or damage due to high current draw.

## TROUBLE SHOOTING INSTRUCTIONS

### 1. Reset the Overload

- Locate the overload relay in the control panel.
- Reset the overload by:  
Pressing the manual reset button on the overload, or  
Touching the reset icon on the HMI screen, only if the panel is equipped with a remote reset function.

## 2. Check Overload Amp Setting

- Do not restart the unit yet
- Inspect the overload setting and compare it to the motor's Full Load Amps (FLA) from the motor nameplate.
- Adjust the overload setting as follows:  
*For motors with a service factor of 1.15 or greater:*  
Set overload to 125% of the FLA.  
*For all other motors (service factor less than 1.15):*  
Set overload to 115% of the FLA

## 3. Restart and Monitor the System

- Start the compressor.
- Monitor the current draw (amperage) on each motor leg.
- Check for continued tripping or abnormal behavior.

## 4. Check Wiring Between Overload and PLC

- If the fault persists even after resetting:  
Check for loose or damaged wiring between the overload relay and the PLC input AI8.  
Ensure good contact at all terminals and verify against the wiring diagram.

## 5. Check Voltage and Current During Operation

- Measure the voltage supply to ensure it matches the motor's required voltage.
- Measure the amperage while the compressor is running.
- Compare both readings to the motor's nameplate values.

## 6. Identify Possible Causes of Overcurrent

- If amperage is consistently high, inspect the following:  
Low Voltage:  
A drop in supply voltage can cause motors to draw more current.  
Confirm that the incoming voltage is within specification.  
Belt Tension:  
Belts that are too tight can cause excessive load on the motor.  
Check belt tension and adjust to manufacturer specifications.

## 7. Final Test and Observation

- After making adjustments, restart the compressor.
- Monitor current and system operation.
- Ensure the fault does not return.

## 8. Replace the Overload (if necessary)

- If the current and voltage are normal, but the overload continues to trip, the overload relay may be faulty.
- Replace the overload with a new one rated correctly for the motor.

## TROUBLE SHOOTING CHART

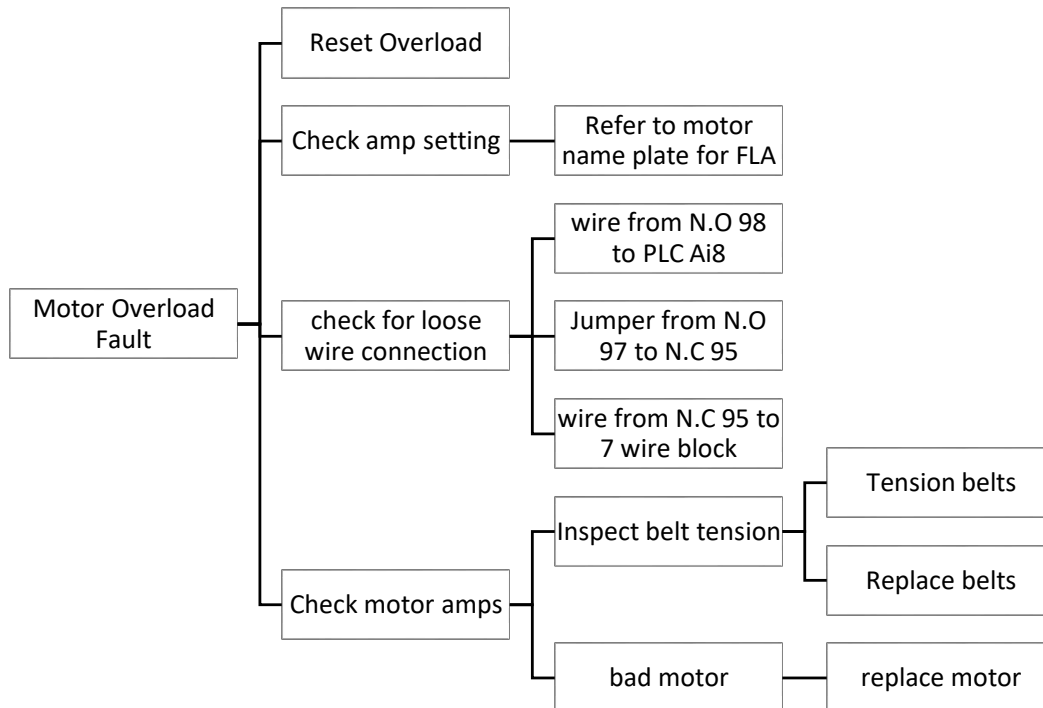

## Oil Temperature Error



## Fault Description

This fault occurs when the PLC does not receive a signal from the oil temperature RTD sensor. This could be due to loose wiring, a disconnected sensor, or a failed RTD.

## TROUBLE SHOOTING INSTRUCTIONS

## 1. Power Down the System

- Turn off power to the unit before inspecting wiring to ensure safety.

## 2. Inspect RTD Wiring

- Look for any loose, cut, or disconnected wires.
- Pay special attention to any quick-disconnect connectors. Ensure all plugs are fully inserted and secure.

## 3. Check PLC Terminal Connections

- Find the wires connected to the PLC terminals AI3 (Analog Input 3) and GND (Ground).
- Make sure the wires are:
  - Fully inserted into the terminals
  - Tightened securely
  - Free of corrosion or damage

#### 4. Test the RTD Sensor

- With the RTD disconnected, use a multimeter to measure resistance across the RTD wires.
- Compare the measured resistance to standard RTD values:  
For a PT1000 sensor, expect ~1000 ohms at 0°C and ~1385 ohms at 100°C.
- If the reading is open, shorted, or outside the expected range, the RTD may be faulty.

#### 5. Replace the RTD (if needed)

- If the RTD is not functioning correctly, replace it.
- Ensure the new RTD is correctly installed and wired.

#### 6. Power Up and Test

- Restore power to the system.
- Monitor the HMI or controller to confirm that the oil temperature signal is now detected.
- Observe system operation to confirm normal behavior.

### TROUBLE SHOOTING CHART

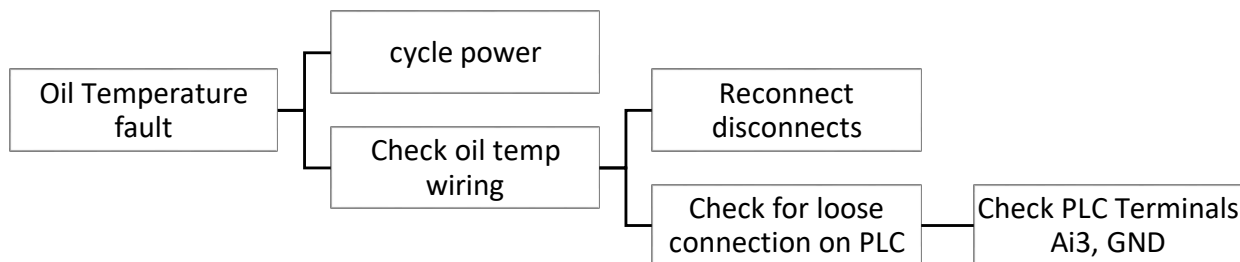

## Oil Temp Failure

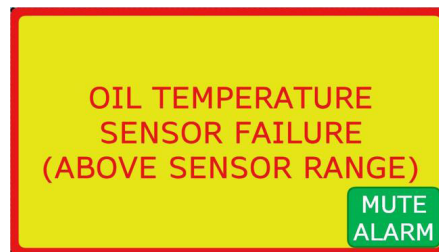

### Fault Description

This fault indicates that the oil temperature reading is outside the sensor's normal operating range.

### TROUBLE SHOOTING INSTRUCTIONS

#### 1. Measure Actual Temperature

- Use a temperature gun or calibrated temperature measuring device to measure the actual oil temperature at the sensor location.

#### 2. Compare Readings

- Compare the measured temperature to the reading reported by the RTD sensor in the system.

#### 3. Evaluate the RTD Sensor

- If the actual (measured) temperature is within normal limits, but the RTD sensor reading is inaccurate or outside the operating range, the sensor may be faulty.

#### 4. Inspect Sensor and Wiring

- Visually inspect the RTD sensor and its wiring for damage, corrosion, or loose connections.
- Repair or reconnect as necessary.

## 5. Test the RTD Sensor

- If available, use a multimeter or an RTD tester to check the resistance of the sensor at the measured temperature. Compare the value to the manufacturer's RTD chart.
- If the sensor does not match expected resistance values, it is likely defective.

## 6. Replace the Sensor (if needed)

- If the RTD sensor is found to be faulty, replace it with a new one of the same type and specification.

## TROUBLE SHOOTING CHART

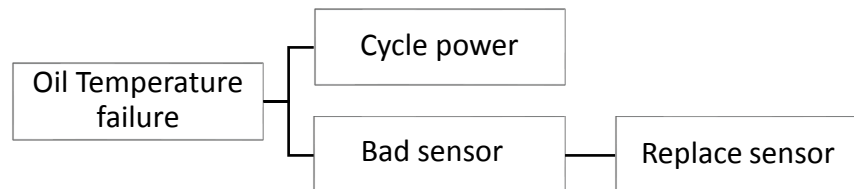

## Air Temperature Error



### Fault Description

This fault occurs when the PLC does not receive a signal from the air temperature RTD sensor. This could be due to loose wiring, a disconnected sensor, or a failed RTD.

## TROUBLE SHOOTING INSTRUCTIONS

### 1. Power Down the System

- Turn off power to the unit before inspecting wiring to ensure safety.

### 2. Inspect RTD Wiring

- Locate the air temperature RTD and its wiring.
- Look for any loose, cut, or disconnected wires.
- Pay special attention to any quick-disconnect connectors:  
Ensure all plugs are fully inserted and secure.

### 3. Check PLC Terminal Connections

- Find the wires connected to the PLC terminals AI4 (Analog Input 4) and GND (Ground).
- Make sure the wires are:  
Fully inserted into the terminals  
Tightened securely  
Free of corrosion or damage

### 4. Test the RTD Sensor

- With the RTD disconnected, use a multimeter to measure resistance across the RTD wires.
- Compare the measured resistance to standard RTD values:  
For a PT1000 sensor, expect ~1000 ohms at 0°C and ~1385 ohms at 100°C.
- If the reading is open, shorted, or outside the expected range, the RTD may be faulty.

### 5. Replace the RTD (if needed)

- If the RTD is not functioning correctly, replace it.
- Ensure the new RTD is correctly installed and wired.

### 6. Power Up and Test

- Restore power to the system.
- Monitor the HMI or controller to confirm that the air temperature signal is now detected.
- Observe system operation to confirm normal behavior.

## TROUBLE SHOOTING CHART

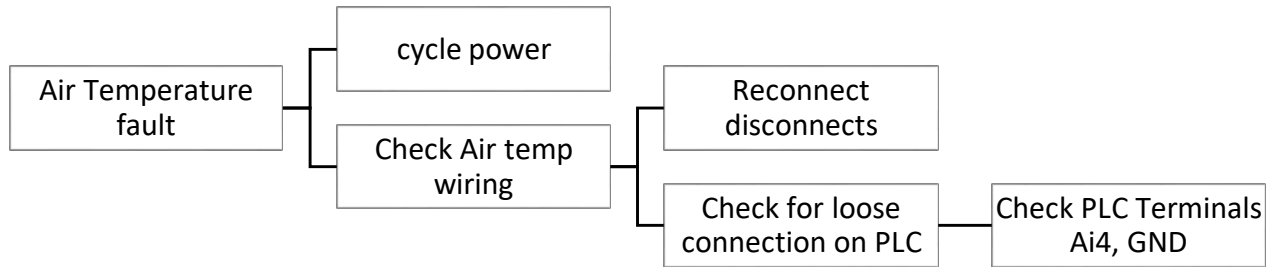

## Air Temperature Failure



### Fault Description

This fault indicates that the air temperature reading is outside the sensor’s normal operating range.

## TROUBLE SHOOTING INSTRUCTIONS

### 1. Measure Actual Temperature

- Use a temperature gun or calibrated temperature measuring device to measure the actual oil temperature at the sensor location.

### 2. Compare Readings

- Compare the measured temperature to the reading reported by the RTD sensor in the system.

### 3. Evaluate the RTD Sensor

- If the actual (measured) temperature is within normal limits, but the RTD sensor reading is inaccurate or outside the operating range, the sensor may be faulty.

### 4. Inspect Sensor and Wiring

- Visually inspect the RTD sensor and its wiring for damage, corrosion, or loose connections.
- Repair or reconnect as necessary.

### 5. Test the RTD Sensor

- If available, use a multimeter or an RTD tester to check the resistance of the sensor at the measured temperature. Compare the value to the manufacturer’s RTD chart.
- If the sensor does not match expected resistance values, it is likely defective.

## 6. Replace the Sensor (if needed)

- If the RTD sensor is found to be faulty, replace it with a new one of the same type and specification.

## TROUBLE SHOOTING CHART

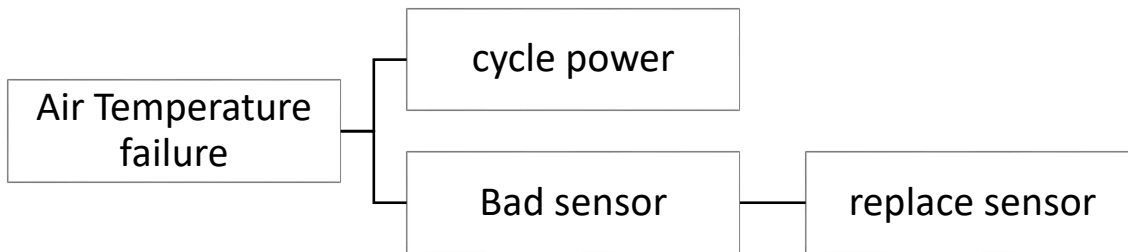

## Contact Coil Failure

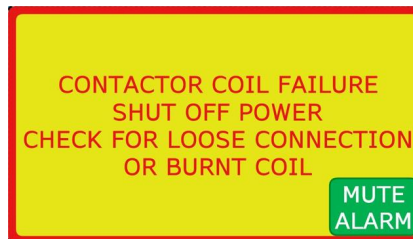

### Fault Description

This fault indicates that the motor contactor coil does not energize after the PLC sends a start command to the compressor. The issue may be due to a burnt coil, loose wiring, or a faulty connection.

## TROUBLE SHOOTING INSTRUCTIONS

### 1. Verify PLC Output

- Confirm that the PLC is sending a start command (check output signal at DO1).
- Ensure the E-stop is not active (i.e., in a released/normal state).

### 2. Check Coil Terminal A1

- Trace the connection from coil terminal A1 → E-stop → PLC DO1.
- Make sure all wiring is secure and not damaged.

### 3. Check Coil Terminal A2

- Check the connection from coil terminal A2 → N.C. 96 on the overload relay.
- Ensure tight and clean connections.

### 4. Check Overload Relay to Terminal Block

- Confirm that N.C. 95 on the overload relay is properly connected to:
  - Terminal 7 on the terminal block.
  - N.O. 97 on the overload relay.

### 5. Check Contactor Feedback Circuit

- Check the connection from:
  - N.O. 97 (overload relay) → N.C. 22 (motor contactor).
  - N.C. 21 → AI6 on the PLC (used for contactor feedback).

### 6. Inspect Wiring

- Visually and physically inspect all wires along the above paths.
- Look for:
  - Loose or corroded terminals
  - Damaged insulation
  - Broken or disconnected wires

### 7. Test the Contactor Coil

- Use a multimeter to measure resistance across the contactor coil (A1 and A2).
- A good coil should show measurable resistance.
- An open (infinite resistance) reading indicates a burnt or faulty coil.

### 8. Replace the Motor Contactor (if needed)

- If the coil is found to be faulty, replace the entire motor contactor with the correct model and rating.

### TROUBLE SHOOTING CHART

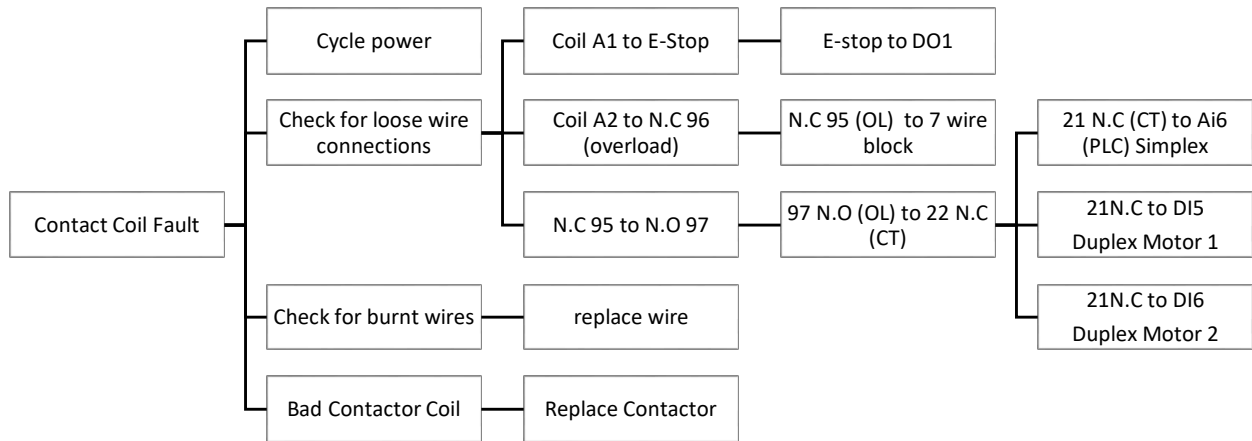

## Troubleshooting Chart

**NOTE:** After an alarm has been cleared, cycle the power off/on or wait approximately 15 seconds before starting the compressor.

**You should always contact an authorized service center before attempting to fix or repair your air compressor. Always make sure electrical power is off before removing any inspection covers or plates or before servicing compressor.**

| Alarm                         | Indicates  | Solutions   |
|-------------------------------|--|---|
| High Oil Temperature Warning  | The oil temperature has met or exceeded 225°F which may impact system performance.   | Allow the oil to cool. Relocate compressor to any area with better ventilation (at least 18 inches from the nearest wall). Clean all cooling surfaces. Reduce compressor duty cycle (repair leaks or add another unit to handle the excess demand)                          |
| High Oil Temperature Shutdown | The oil temperature has met or exceeded 240°F. The system has shut down due to high oil temperature that has exceeded safe operating limits. | Allow the system to cool down fully. Ensure that the cooling fans, vents, and radiator are free from dust, dirt, or obstructions. Check the oil level and replace it if necessary, following the manufacturer's specifications.   |
| High Air Temperature Warning  | The air temperature has met or exceeded 225°F which may impact system performance.   | Confirm that the air intake area is clear and that the cooling system is functioning correctly. Allow the system to cool before restarting.   |
| High Air Temperature Shutdown | The air temperature has met or exceeded 240°F. The system has shut down due to high oil temperature that has exceeded safe operating limits. | Let the compressor cool down completely before attempting a restart. Excessive load or extended continuous operation can lead to high temperatures. Consider reducing load or allowing cool-down periods during heavy usage.  |
| Transducer Fail               | A complete failure of the pressure transducer, which may prevent accurate pressure readings.   | Power cycle the system to reset. If the alarm remains, contact support to replace the transducer.   |
| Transducer Error              | An issue with the transducer, which may affect pressure monitoring accuracy.   | Check the wiring connections to the transducer for any visible issues, then reset the control panel. If the error persists, arrange for service.  |
| Oil Temperature Sensor Fail   | The oil temperature sensor is not functioning, which could prevent proper temperature monitoring.  | Inspect the sensor connections and power cycle the system. If the alarm continues, the sensor may need replacement. Excessive load or extended continuous operation can lead to high temperatures. Consider reducing load or allowing cool-down periods during heavy usage. |
| Oil Temperature Sensor Error  | There may be an issue with the oil temperature sensor, which may impact the system's ability to monitor and regulate oil temperature.        | Verify that the sensor's wiring connections are secure and undamaged. Reset the control panel. If the error persists, contact technical support, as the sensor may need replacement.  |

| Alarm                        | Indicates   | Solutions  |
|------------------------------|---|--|
| Air Temperature Sensor Fail  | A malfunction in the air temperature sensor, impacting the system's ability to monitor air temperature.                                     | Check for loose or damaged sensor wiring. If unresolved after restarting, contact technical support for assistance.  |
| Air Temperature Sensor Error | A malfunction with the air temperature sensor, potentially effecting accurate temperature readings.   | Inspect the sensor and its wiring for visible damage or loose connections. Reset the control panel. If the alarm continues, contact support for further diagnostics or sensor replacement.   |
| Door Open                    | Access door is open, potentially exposing internal components.  | Ensure all doors are securely closed. Restart the system to clear the alarm if the door is properly latched but the alarm remains active.  |
| Motor Overload               | The compressor motor is operating beyond its rated capacity, or the power supply does not match the motor's specifications.                 | Ensure that the power supply matches the motor's specifications and that there are no voltage fluctuations. Ensure that the compressor is not being overutilized beyond its designed capacity. Reduce the load if necessary. Allow the motor to cool down before restarting the system. If the alarm persists after these checks, contact technical support for a detailed inspection and possible motor maintenance or replacement. |
| Contactor Stuck              | The contactor, which controls the electrical power to the motor, is stuck in the closed or open position, preventing normal operation.      | Turn off power to the compressor. Visually examine the contactor for any signs of damage, wear, or debris that might cause it to stick. Attempt to manually operate the contactor to ensure it moves freely. Ensure all electrical connections to the contactor are secure and free from corrosion or damage. If the contactor remains stuck after these steps, contact technical support to replace the faulty component.           |
| Over Pressure Alarm          | The system pressure has met or exceeds the maximum safe operating limit of 200 PSI, which could lead to equipment damage or safety hazards. | Check that the pressure relief valve is functioning properly and not obstructed. Allow the compressor to cool down and stabilize before restarting. If the alarm continues, contact technical support for a comprehensive system check and potential component repairs.  |
| Emergency Stop               | The emergency stop (E-Stop) has been activated, halting all compressor operations immediately for safety reasons.                           | Reset the emergency stop. After the alarm has been cleared, cycle the power off/on or wait approximately 15 seconds before starting the compressor.  |
| Contact Failure              | A failure in the electrical contacts within the control panel.  | Turn off power to the compressor. Open the control panel and press the reset buttons on the overloads. Check for loose or damaged wire. Close the control panel and restart the compressor.  |

# Duplex Reciprocating Compressor Panel Diagram

Plato Touchscreen Control Panel

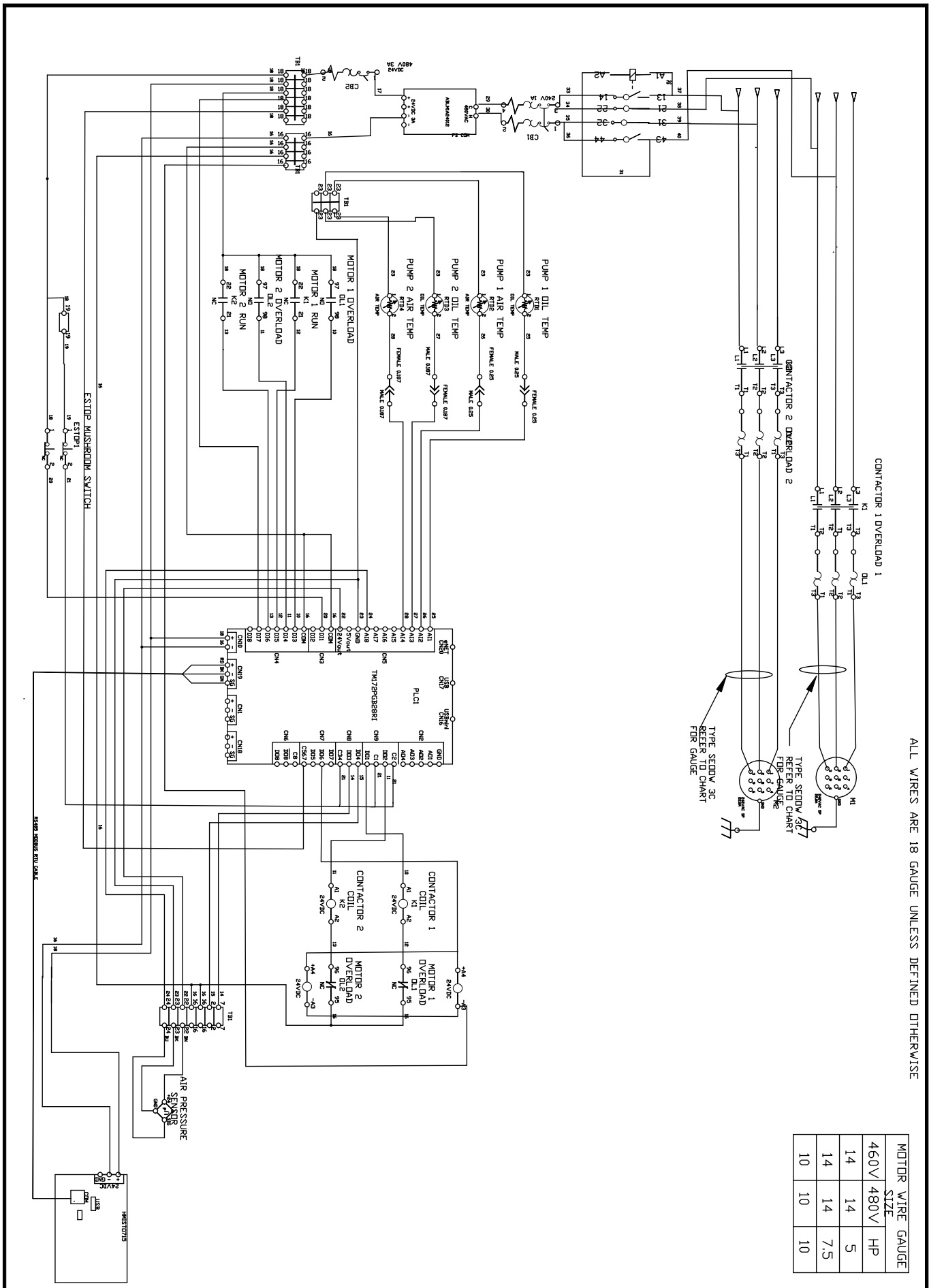







**Industrial Gold**

600 S 2nd Ave  
Mansfield, TX, 76063

**1-800-531-9656**

Fax 972-352-6364

**Quality Air Compressor at a Great Price.**