

TAG:

Submittal

**2.5 / 3 Ton Wall-Mount
Air Handler - 1 Phase
DWM5P301B00*
DWM5P361B00***

Standard Features:

- Multi-speed PSC motor design.
- Drain pan with bottom primary and secondary drain connections..
- Built-in wall-hanging bracket.
- Optional electric heater kits: 5, 7.5, 10kW.
- All-aluminum heat exchanger prevent for formicary corrosion.
- R32 refrigerant sensor is factory-installed, ensures safe operation.

FOR ILLUSTRATIVE PURPOSES ONLY

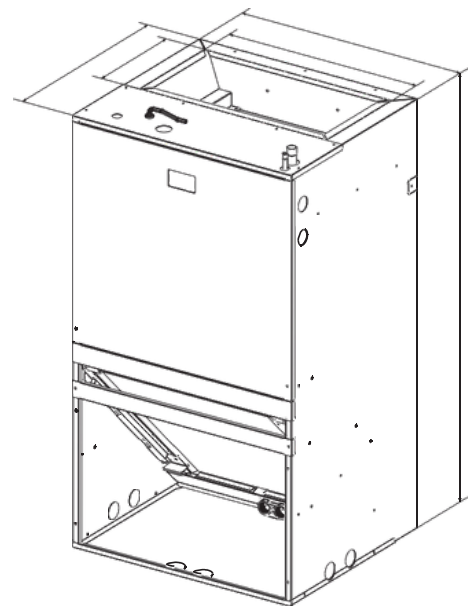

| Model | W - inch [mm] | H - inch [mm] | L - inch [mm] | GAS VALVE SIZE in. | LIQUID VALVE SIZE in. |
|--------------|---------------|---------------|---------------|--------------------|-----------------------|
| DWM5P301B00* | 22[559] | 39-3/5 [1006] | 19[485] | 3/4 | 3/8 |
| DWM5P361B00* | 22[559] | 39-3/5 [1006] | 19[485] | 3/4 | 3/8 |

PRODUCT SPECIFICATIONS

| NOMINAL RATING | 2.5 Ton | 3Ton |
|---|------------------|------------------|
| Cooling (BTU/h) | 26,800 | 33,000 |
| Rate CFM | 960 | 1,100 |
| External Static Pressure (in.w.c) [Pa] | 0.58[1 45] | 0.58 [145] |
| ELECTRICAL DATA | | |
| Voltage / Phase (60 Hz) | 208/230 / 1 | 208/230 / 1 |
| Min. / Max. Voltage | 187/253 | 187/253 |
| MCA | 2.79 | 2.79 |
| MOP | 3 | 3 |
| INDOOR UNIT COIL | | |
| Type | Tube & Fin | Tube & Fin |
| Material | ALL-Aluminum | ALL-Aluminum |
| Tube Size (in.) | 9/32 | 9/32 |
| FAN MOTOR | | |
| Motor Type | PSC | PSC |
| Capacitor(uF) | 15 | 15 |
| Horsepower (HP) | 3/10 | 3/10 |
| Full Load Amps (FLA) | 2.23 | 2.23 |
| BLOWER | | |
| Material | Metal | Metal |
| Diameter(in.) | 9 | 9 |
| Coil Drain Connection FPT (in.) | 3/4" | 3/4" |
| REFRIGERATION CONNECTION | | |
| Liquid Line Size ("O.D.) | 3/8" | 3/8" |
| Suction Line Size ("O.D.) | 3/4" | 3/4" |
| SHIPPING DIMMENTION - (IN.) [mm] | | |
| Width | 24-5/8[625] | 24-5/8[625] |
| Height | 42-15 /16[10 90] | 42-15 /16[10 90] |
| Length | 22-1/4[565] | 22-1/4[565] |
| SHIPPING WEIGHT | | |
| Shipping (LBS.) [kg] | 119[53 .9] | 119 [53.9] |



Note: Product specifications change from time to time as product improvements and developments are released and may vary from those in this document.

PRODUCT SPECIFICATIONS

| Heater Kit Model | Electric Heater (kW) | Min. Circuit Ampacity | | Max. Fuse or Breaker (HACR) Ampacity | | REFERENCE AIR HANDLER USE | Min. Heating Blower Speed (AC/HP) PSC MOTOR | | |
|------------------|----------------------|-----------------------|------|--------------------------------------|------|---------------------------|---|--------|-----------|
| | | 208V | 230V | 208V | 230V | | LOW | MEDIUM | HIGH |
| | | AEHK-05(WM) | 5 | 22.8 | 24.9 | | 25 | 25 | 30K (PSC) |
| | | | | | | 36K (PSC) | • | • | • |
| AEHK-08(WM) | 7.5 | 34.8 | 37.9 | 35 | 40 | 30K (PSC) | × | • | • |
| | | | | | | 36K (PSC) | × | • | • |
| AEHK-10(WM) | 10 | 45.4 | 49.8 | 50 | 50 | 30K (PSC) | × | • | • |
| | | | | | | 36K (PSC) | × | • | • |

× = Not available, • = Available

| Heater Kit Model | Electric Heater (kW) | Min. Circuit Ampacity | | Max. Fuse or Breaker (HACR) Ampacity | | REFERENCE AIR HANDLER USE | Min. Heating Blower Speed (AC/HP) ECM MOTOR | | | |
|------------------|----------------------|-----------------------|------|--------------------------------------|------|---------------------------|---|----|-----------|---|
| | | 208V | 230V | 208V | 230V | | 2 | 3 | 4 | 5 |
| | | AEHK-05(WM) | 5 | 22.8 | 24.9 | | 25 | 25 | 30K (ECM) | • |
| | | | | | | 36K (ECM) | • | • | • | • |
| AEHK-08(WM) | 7.5 | 34.8 | 37.9 | 35 | 40 | 30K (ECM) | × | • | × | • |
| | | | | | | 36K (ECM) | × | • | • | • |
| AEHK-10(WM) | 10 | 45.4 | 49.8 | 50 | 50 | 30K (ECM) | × | • | × | • |
| | | | | | | 36K (ECM) | × | • | • | • |

× = Not available, • = Available



Note: Product specifications change from time to time as product improvements and developments are released and may vary from those in this document.

PRODUCT SPECIFICATIONS

| AIR HANDLER MODEL | Motor Speed Factory Default (*) | AIR FLOW PERFORMANCE (PSC MOTOR) | | | | | | | | | |
|-------------------|------------------------------------|--|------|----------|----------|----------|----------|----------|----------|----------|----------|
| | | External Static Pressure-Inches W.C. (kPa) | | | | | | | | | |
| | | | 0(0) | 0.1(.02) | 0.2(.05) | 0.3(.07) | 0.4(.10) | 0.5(.12) | 0.6(.15) | 0.7(.17) | 0.8(.20) |
| 30K (PSC) | Low | CFM | 1065 | 1048 | 1019 | 978 | 924 | 857 | 777 | 685 | 580 |
| | Medium (*) | CFM | 1296 | 1263 | 1221 | 1170 | 1109 | 1040 | 961 | 873 | 776 |
| | High | CFM | 1458 | 1415 | 1365 | 1308 | 1244 | 1173 | 1096 | 1011 | 919 |
| 36K (PSC) | Low | CFM | 1065 | 1048 | 1019 | 978 | 924 | 857 | 777 | 685 | 580 |
| | Medium | CFM | 1296 | 1263 | 1221 | 1170 | 1109 | 1040 | 961 | 873 | 776 |
| | High (*) | CFM | 1458 | 1415 | 1365 | 1308 | 1244 | 1173 | 1096 | 1011 | 919 |

(*) = Factory Default

Note:

1. Airflow ratings are based on dry coil operation at 230V, without electric heat or filter. Verify that line voltage remains stable at the rated 230V to ensure consistent air delivery.
2. Airflow performance is identical for both front-return and bottom-return configurations.
3. System airflow requirement: 300–450 CFM per ton. (Note: Indoor Units equipped with electric heat kits require 350–450 CFM per ton.)
4. Rated airflow must be maintained during full-load operation of the equipment.
5. The duct system has the greatest impact on delivered airflow. Since the duct system is fully controlled by the contractor, only industry-recognized procedures should be applied.
6. Duct design and installation must be performed carefully. Improper layout or poor workmanship can reduce system capacity and efficiency.
7. Supply ducts and diffusers must be properly sized and located along the perimeter of the conditioned space. Undersized or misapplied diffusers can cause noise, drafts, or inadequate ventilation. Return grilles must also be correctly sized to provide sufficient airflow back to the blower.
8. The installer must balance the air distribution system to ensure quiet, uniform airflow throughout all zones. Air balancing should be verified using appropriate test instruments.

Important:

1. When model 30 and 36 used with electrical heater kit 7.5kW and 10kW, you need to ensure that the air volume is not less than 1100 CFM.



Note: Product specifications change from time to time as product improvements and developments are released and may vary from those in this document.

PRODUCT SPECIFICATIONS

| AIR HANDLER MODEL | Motor Speed Factory Default (*) | AIR FLOW PERFORMANCE (ECM MOTOR) | | | | | | | | | |
|-------------------|------------------------------------|--|------|----------|----------|----------|----------|----------|----------|----------|----------|
| | | External Static Pressure-Inches W.C. (kPa) | | | | | | | | | |
| | | | 0(0) | 0.1(.02) | 0.2(.05) | 0.3(.07) | 0.4(.10) | 0.5(.12) | 0.6(.15) | 0.7(.17) | 0.8(.20) |
| 30K (ECM) | 2 | CFM | 1048 | 1008 | 979 | 933 | 884 | 836 | 770 | 724 | 680 |
| | 3(*) | CFM | 1159 | 1121 | 1093 | 1059 | 1016 | 965 | 915 | 850 | 808 |
| | 4 | CFM | 1257 | 1231 | 1199 | 1169 | 1140 | 1095 | 1051 | 1000 | 943 |
| | 5 | CFM | 1472 | 1438 | 1404 | 1370 | 1336 | 1302 | 1268 | 1234 | 1200 |
| 36K (ECM) | 2 | CFM | 1048 | 1008 | 979 | 933 | 884 | 836 | 770 | 724 | 680 |
| | 3 | CFM | 1159 | 1121 | 1093 | 1059 | 1016 | 965 | 915 | 850 | 808 |
| | 4(*) | CFM | 1257 | 1231 | 1199 | 1169 | 1140 | 1095 | 1051 | 1000 | 943 |
| | 5 | CFM | 1472 | 1438 | 1404 | 1370 | 1336 | 1302 | 1268 | 1234 | 1200 |

(*) = Factory Default

Note:

- Airflow ratings are based on dry coil operation at 230V, without electric heat or filter. Verify that line voltage remains stable at the rated 230V to ensure consistent air delivery.
- Airflow performance is identical for both front-return and bottom-return configurations.
- System airflow requirement: 300–450 CFM per ton. (Note: Indoor Units equipped with electric heat kits require 350–450 CFM per ton.)
- Rated airflow must be maintained during full-load operation of the equipment.
- The duct system has the greatest impact on delivered airflow. Since the duct system is fully controlled by the contractor, only industry-recognized procedures should be applied.
- Duct design and installation must be performed carefully. Improper layout or poor workmanship can reduce system capacity and efficiency.
- Supply ducts and diffusers must be properly sized and located along the perimeter of the conditioned space. Undersized or misapplied diffusers can cause noise, drafts, or inadequate ventilation. Return grilles must also be correctly sized to provide sufficient airflow back to the blower.
- The installer must balance the air distribution system to ensure quiet, uniform airflow throughout all zones. Air balancing should be verified using appropriate test instruments.

Important:

- When model 30 and 36 used with electrical heater kit 7.5kW and 10kW, you need to ensure that the air volume is not less than 1100 CFM.



Note: Product specifications change from time to time as product improvements and developments are released and may vary from those in this document.