

## Force H3X Energy Storage System

### Quick Guide

(FH3X-8K/10K/12K/15K-HY-3P-10/15/20/25/30/35)

#### WARNING

Warning: Read the user manual for product information and safety precautions before installing the product. The personal injury or property damage caused by failure to use the product in accordance with the this document and the user manual is not covered by the product warranty.

## 01 System Introduction

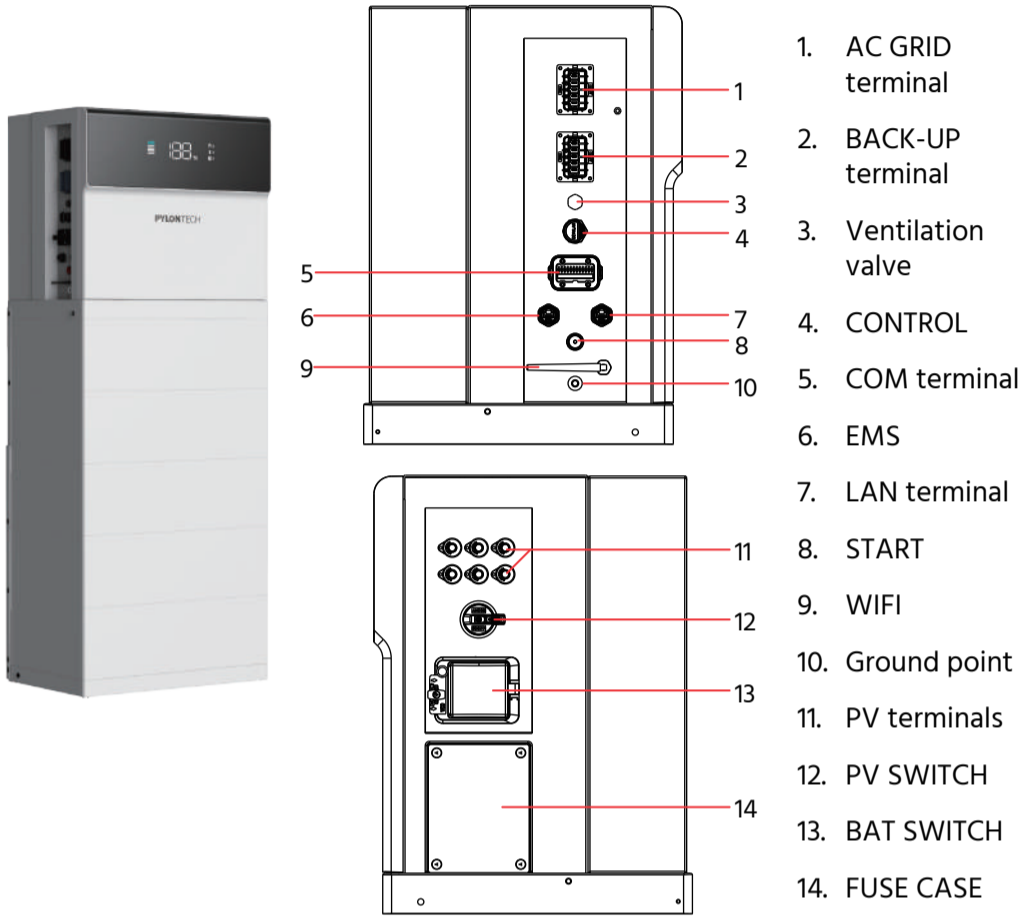

## 02 Installation Requirements

- FH3X system must not be immersed in water. The battery base cannot be exposed to rain or other water sources. As a suggestion, the base's height shall be 300 mm above the ground.
- The support surface should have sufficient load-bearing capacity to support a minimum weight of 300 kg. The system must be installed on a fixed and flat support surface.

## 03 Mounting the Base

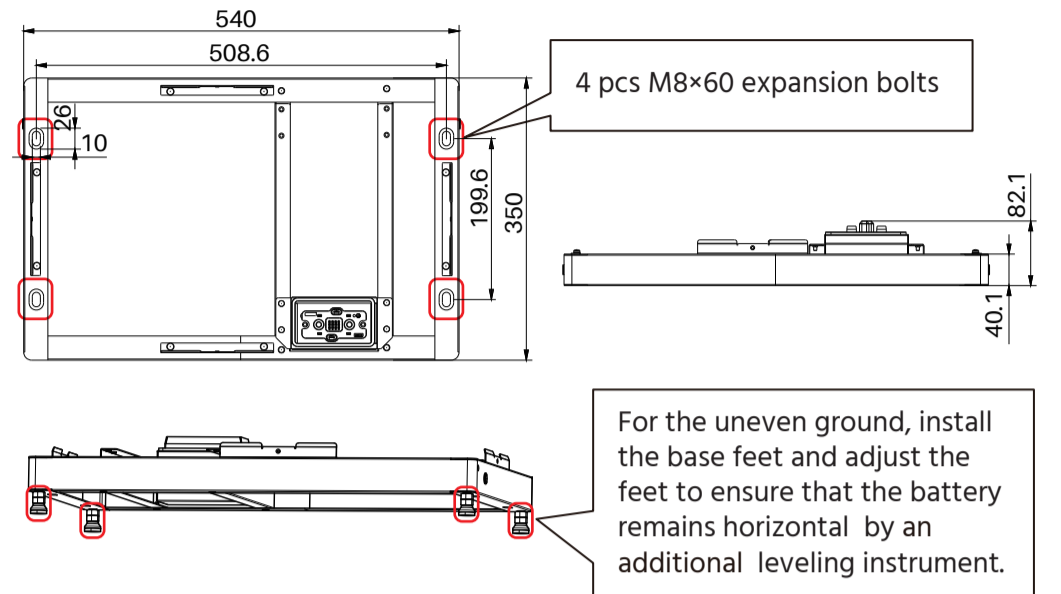

## 04 Installing the Battery Module onto the Base

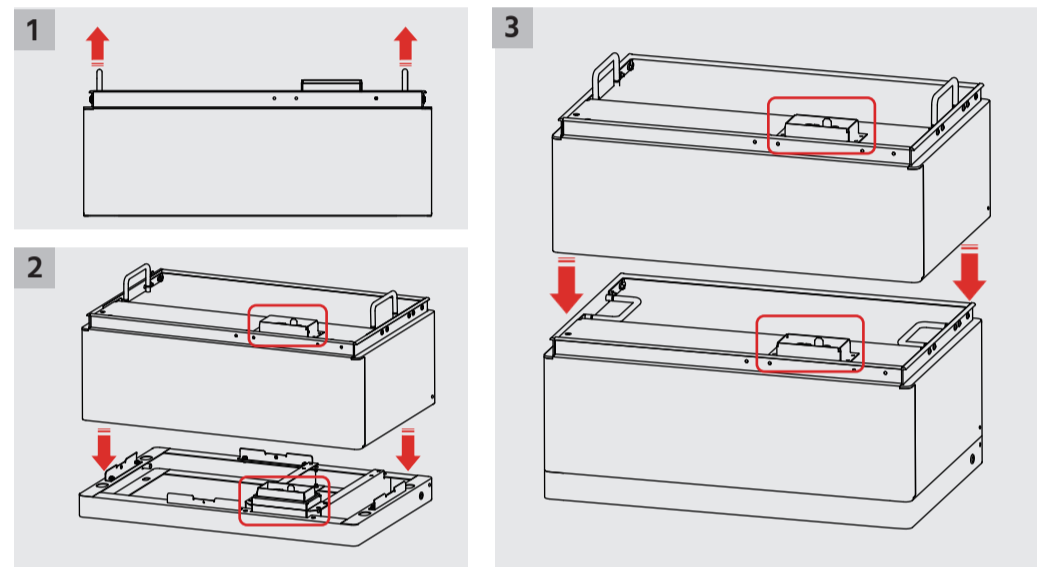

## 05 Installing the Power Controller onto the Battery Module

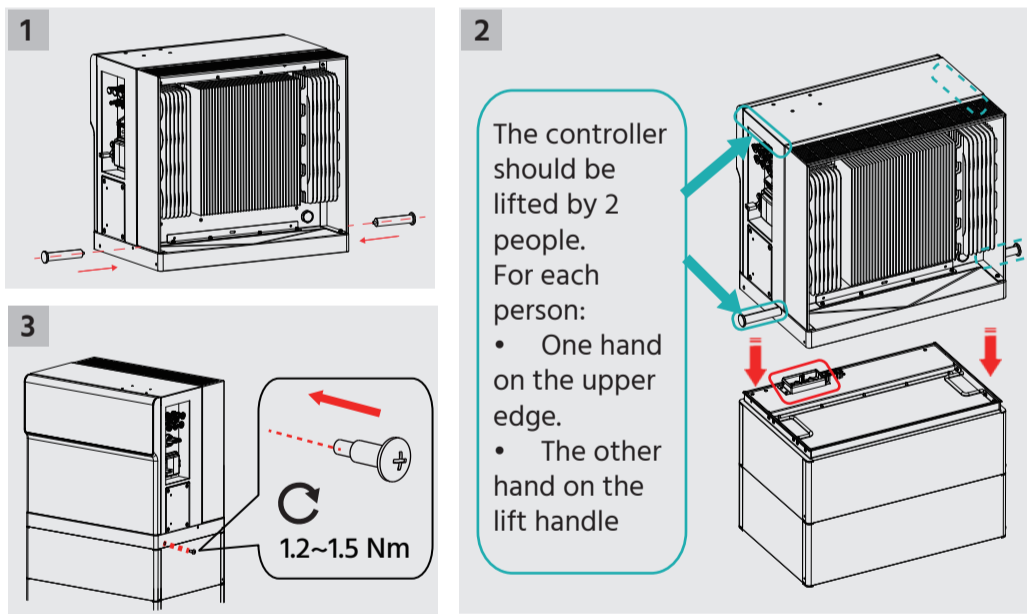

## 07 Installing the Anti-Topping Brackets for the System

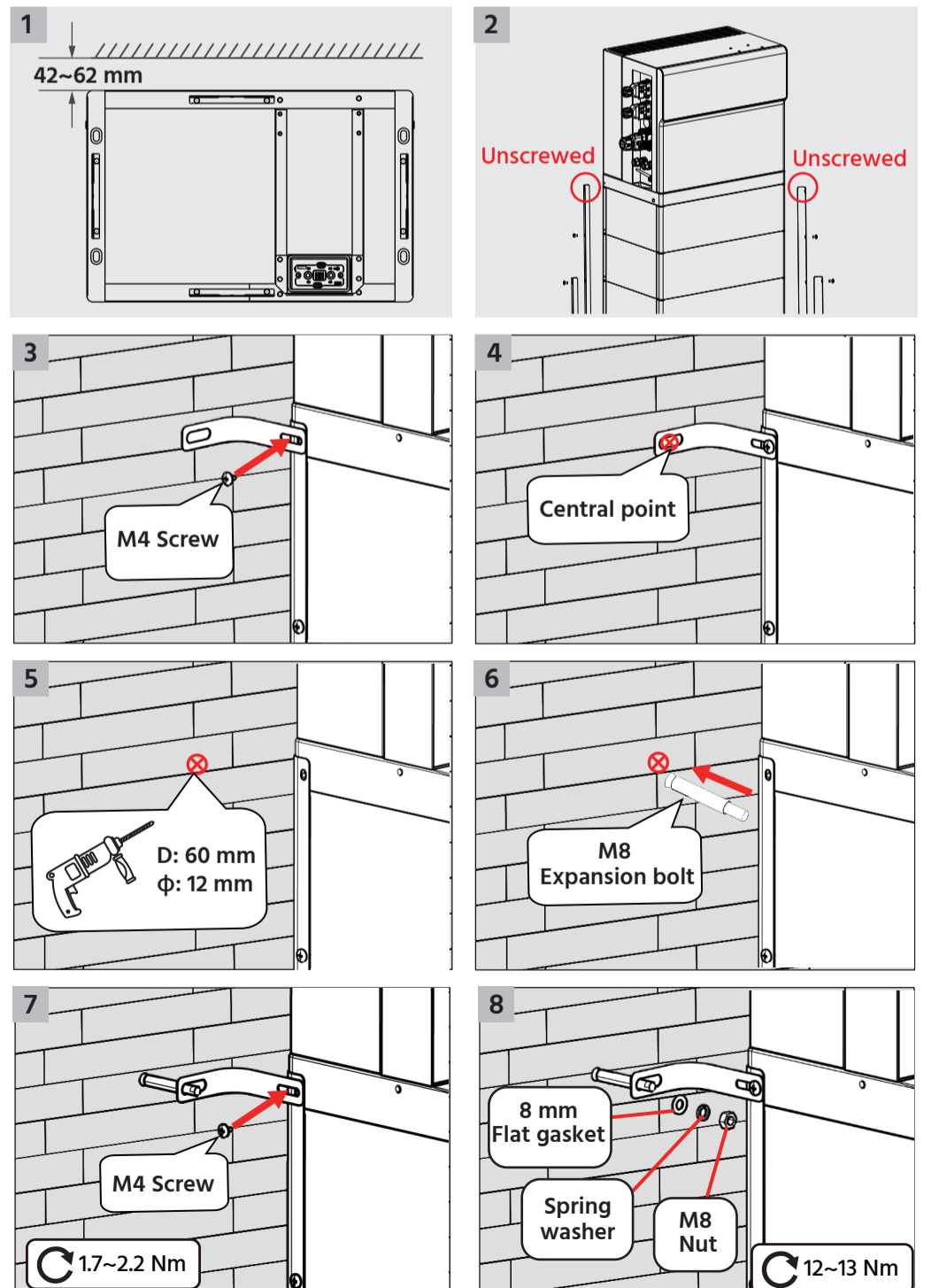

## 06 Installing the Metal Brackets for the System



## 08 Grounding

The system modules has 3 grounding points as follows. Any one of these grounding points can be used for grounding.

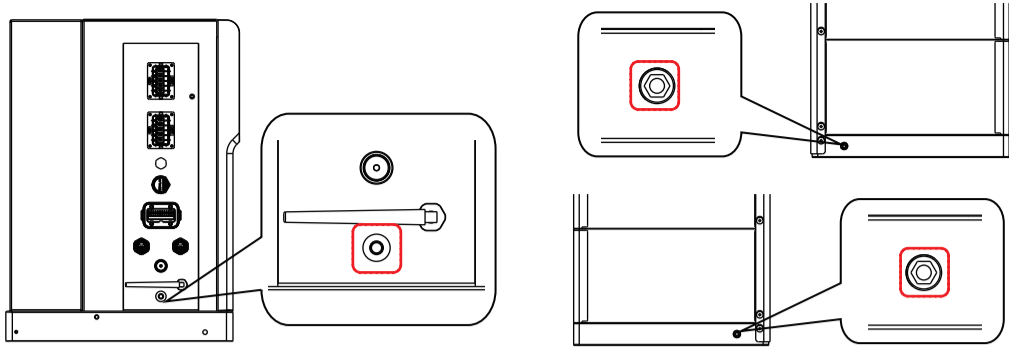

## 09 PV Connector Assembly and Connection

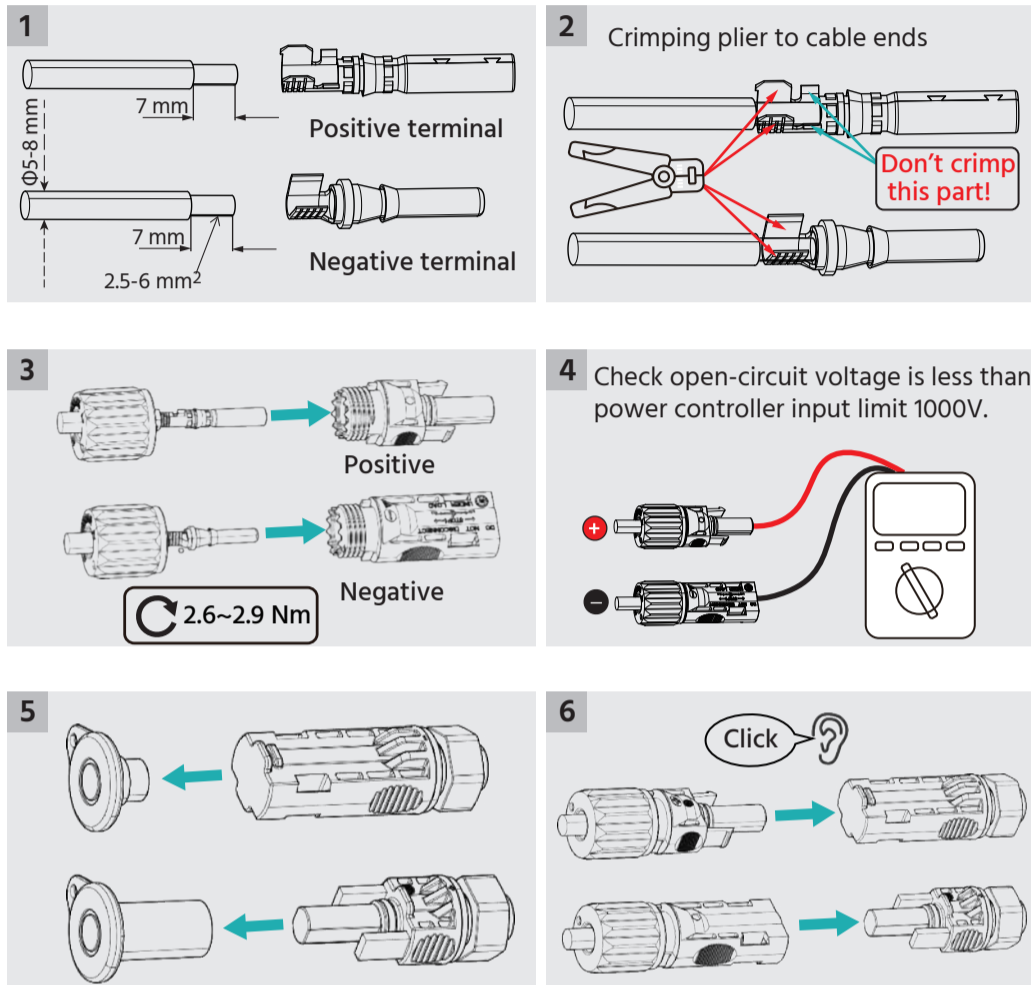

## 10 AC Connector Assembly and Connection

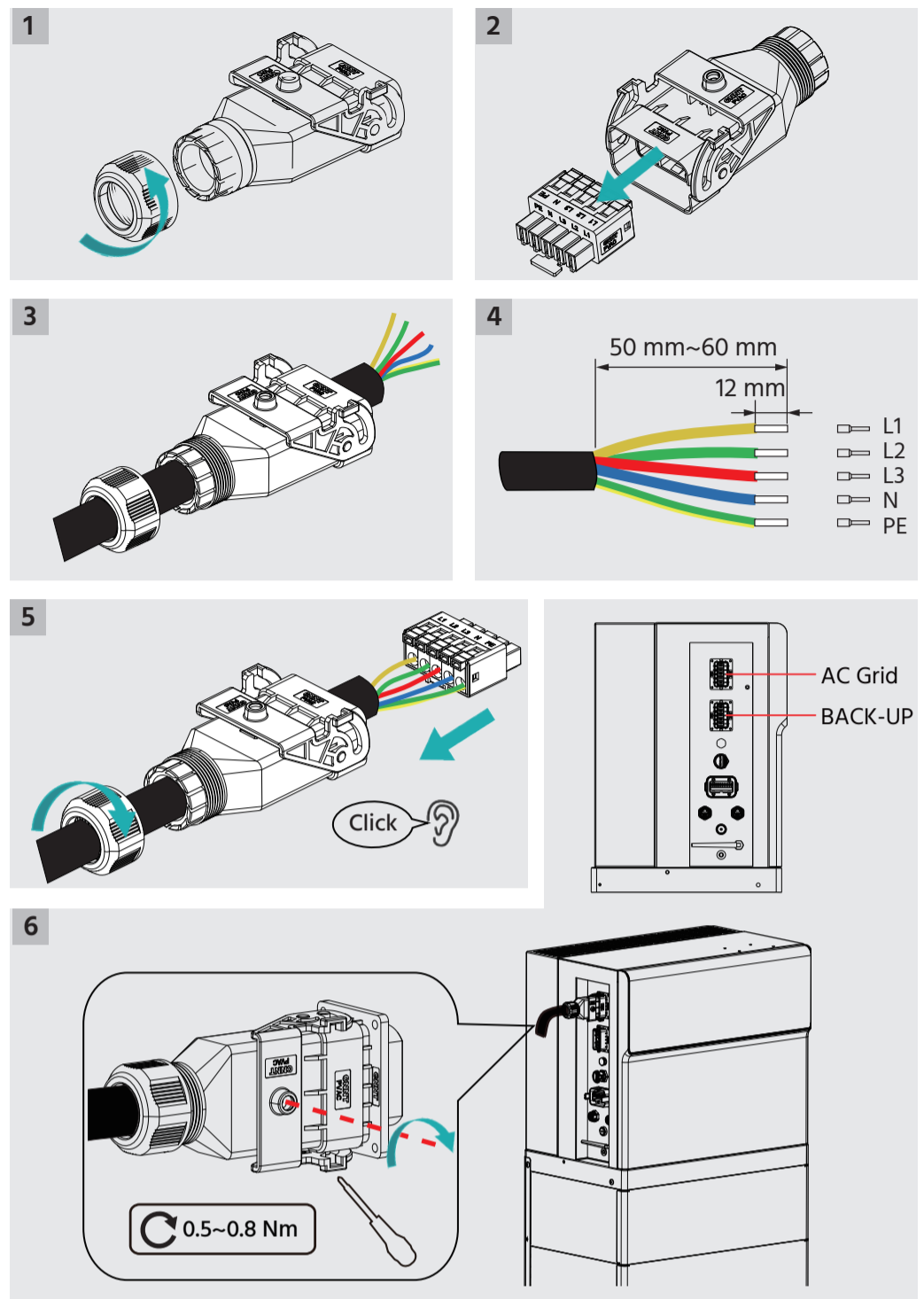

## 11 Communication Connector Assembly and Connection

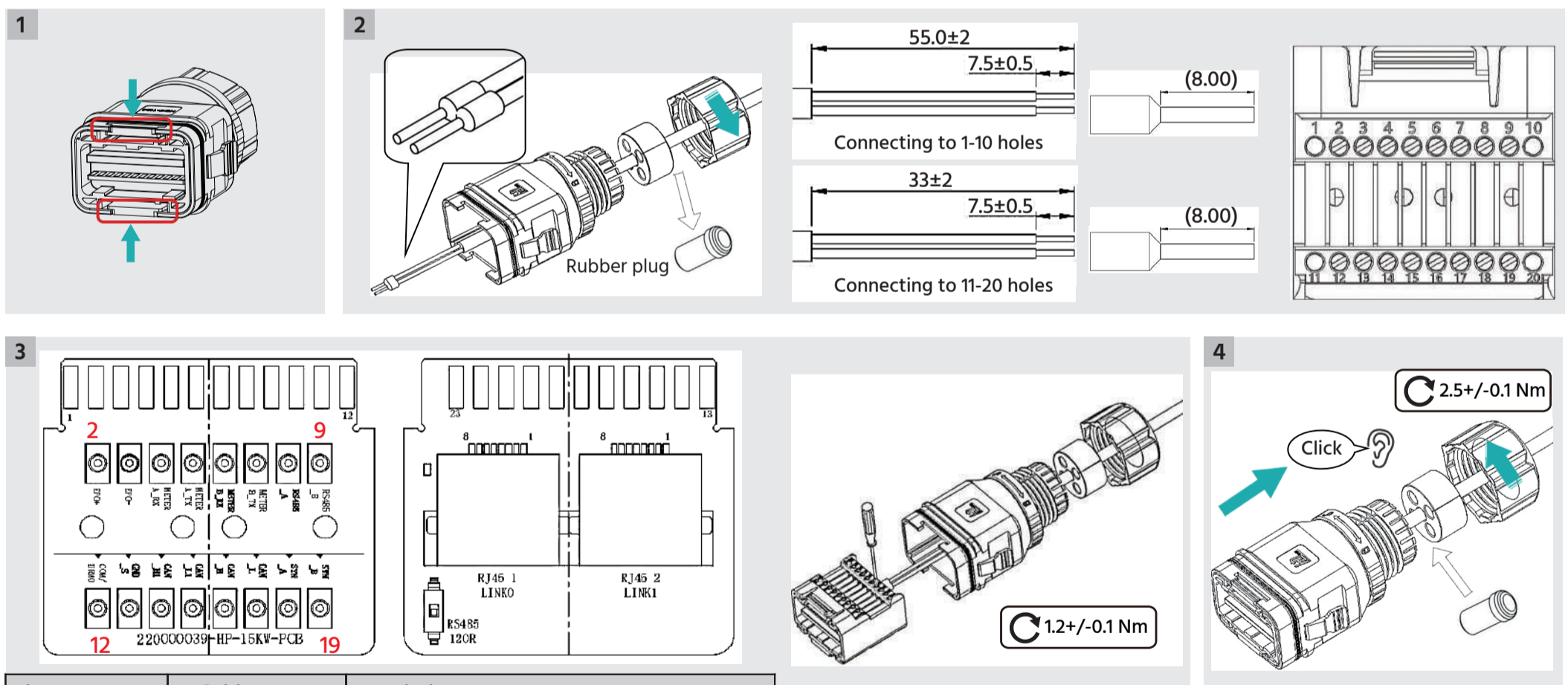

Pin	Definition	Description
Pin 2	EPO+	Emergency stop button signal, to be short-circuited via external switch, for manual quick stop in case of emergency
Pin 3	EPO-	
Pin 4	METERA_RX (CT+)	For communication connection to meter
Pin 5	METERA_TX (CT-)	
Pin 6	SHARE_I_R	
Pin 7	SHARE_I_S	
Pin 8	SHARE_I_T	For parallel connection
Pin 9	GNDS	
Pin 14	DRM0	
Pin 15	GNDS	For AS4777 standard (Only DRM0 is available)
RJ45-2	LINK0	
RJ45-2	LINK1	For parallel connection

