

Circular Interior Design Guide

A handbook for circular economy interior design

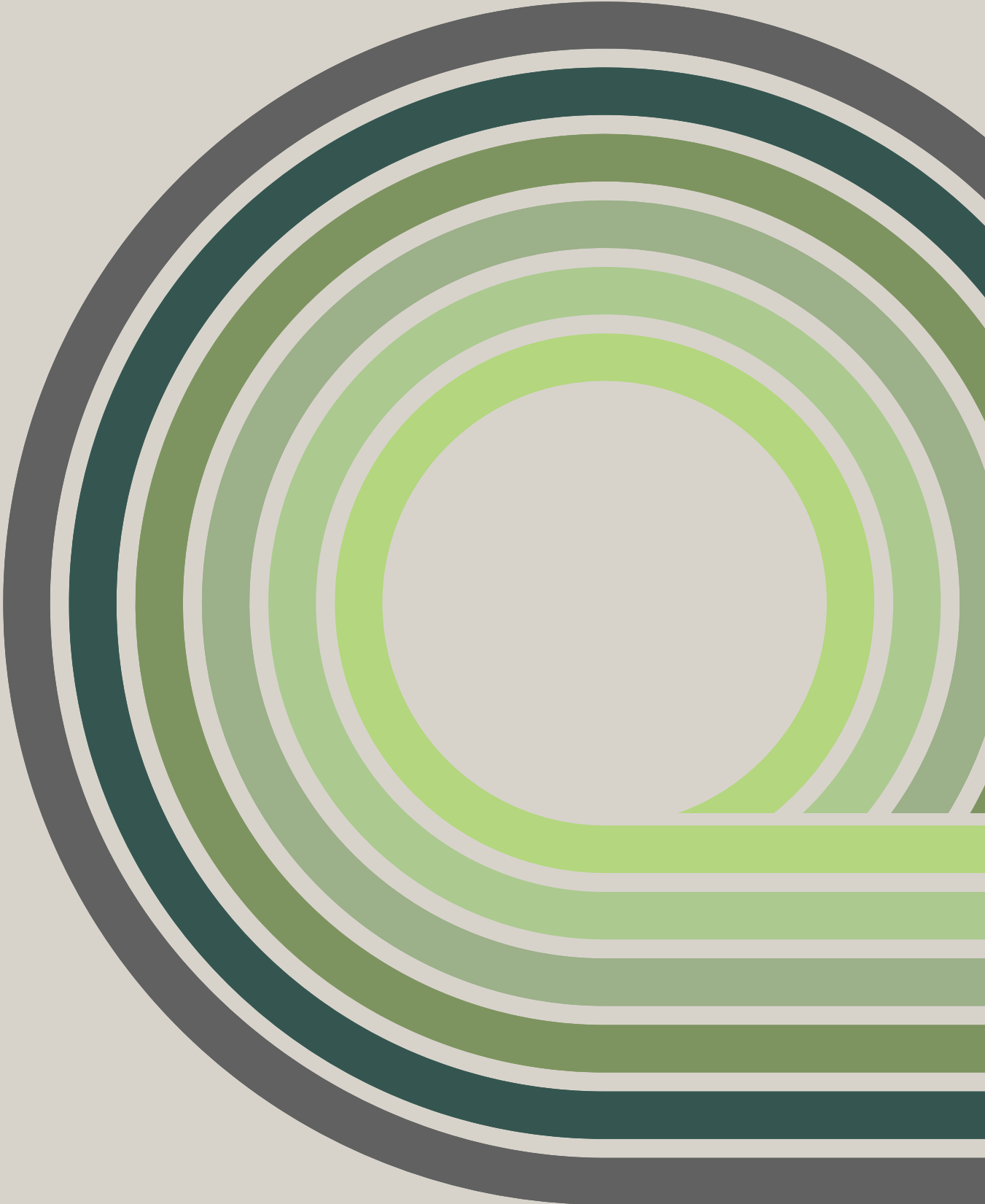



XFrame Circular Interior Design Guide | March 2023

Authored by G. Finch with support from K. Martin, L. Ransfield and B. Waddington.
XFrame | Wellington, New Zealand and Adelaide, Australia

All images are the exclusive property of XFrame PTY Ltd.

'XFrame' and the XFrame logo are registered trademarks of XFrame PTY Ltd.

All technical information supplied herewithin should be verified by independent professionals and/or XFrame.

For more information, please inquire at hello@xframe.com.au

**Designed for now,
built for later.**



Transforming Our Sector

The building and construction industry is the world's largest consumer of raw virgin materials while also being the largest producer of solid waste. Little thought is given to how building materials might be efficiently recovered and reused. Economic pressures mean that low quality and chemically modified composite materials dominate modern construction methods.

Urgent change is needed to reduce the impact of construction on the environment and ensure our buildings are designed for the future.

When to use this guide:

- × When designing interior spaces to meet Circular Economy requirements.
- × If planning to use XFrame in an interior setting.

Who is this guide for:

Architects, interior designers, developers, facility managers, project managers, draftspeople, building surveyors, builders and specifiers.

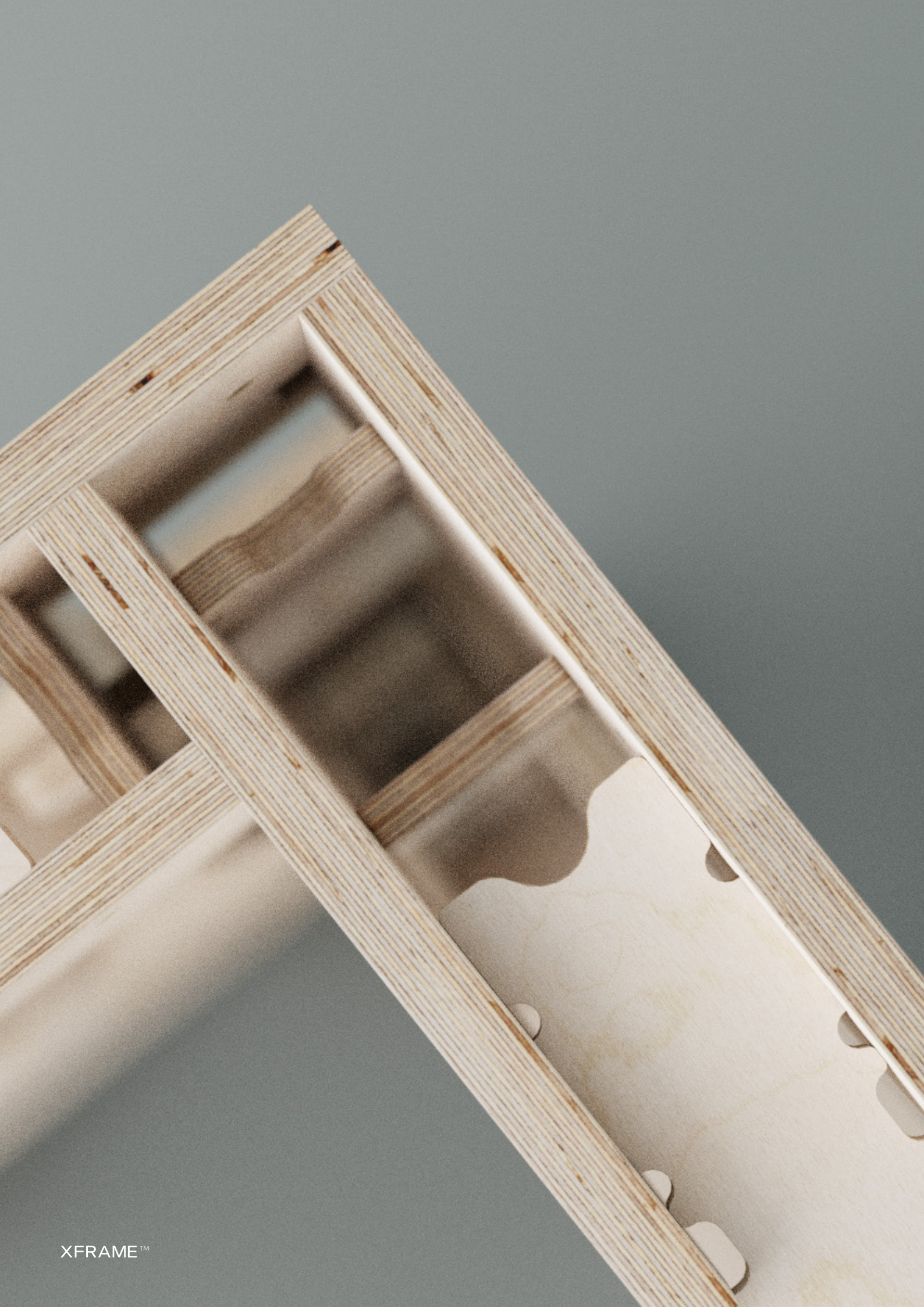

XFRAME™

Contents

A1. Circular Economy Interior Design

- × Introduction
- × The Circular Economy
- × 4 Pillars of Circular Interior Design
- × Circular Design Criteria
- × Buildings as Layers
- × Engineered Wood and the Circular Economy

A2. XFrame and the Circular Economy

- × Overview
- × Modular Logic
- × Circular Features

B1. XFrame Technical Design Guidance

- × Interior Applications
- × Technical Specifications
- × System Anatomy
- × Modular Planning Rules
- × Guidance for Non-module-conforming Walls
- × Cheat-sheet
- × Openings
- × Finishes

C1. Engaging with XFrame

- × Design Process
- × Delivery Process
- × Approvals



A1.

The Circular Economy

The Circular Economy (circularity) is a collection of design and specification criteria that aim to improve the ability of a product's (or building's) constituent parts to be recovered and reused. The ultimate ambition of circularity is to eliminate waste by creating an economy that is 'circular'. In this economy, products (such as buildings) must be designed to allow components to be recovered and reused without creating damaged, contaminated or waste materials.

Applying the circular economy to buildings is a crucial step in reducing waste and lessening the negative impact of modern society on our planet. Buildings are the largest consumer of new raw materials, and are responsible for more than 35% of the world's waste. In nations with a younger building stock and less sophisticated material recycling methods (such as New Zealand, Australia and the United States), construction waste can represent up to 50% of total annual waste volumes.

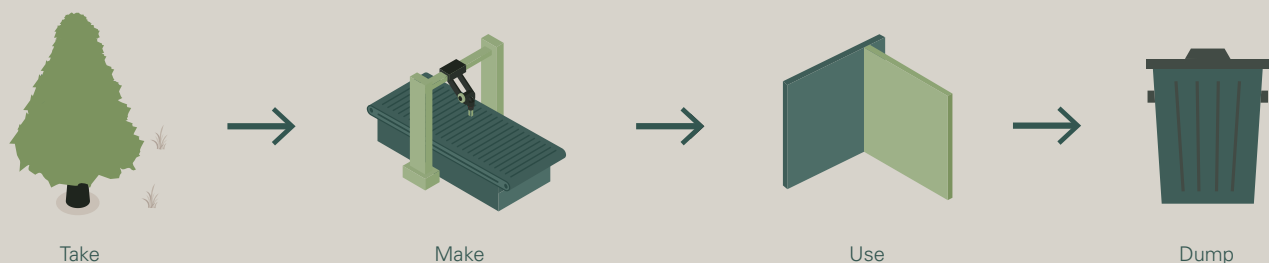

The current 'linear' construction economy.

Circularity in buildings is best achieved through design and specification. The type of spaces created, the shape of those spaces, the materials selected and the type of structural and fixings systems adopted all significantly influence end-of-life deconstruction and reuse performance. Adherence to the guidance in this document will help ensure spaces are designed in alignment with the aims of the Circular Economy.

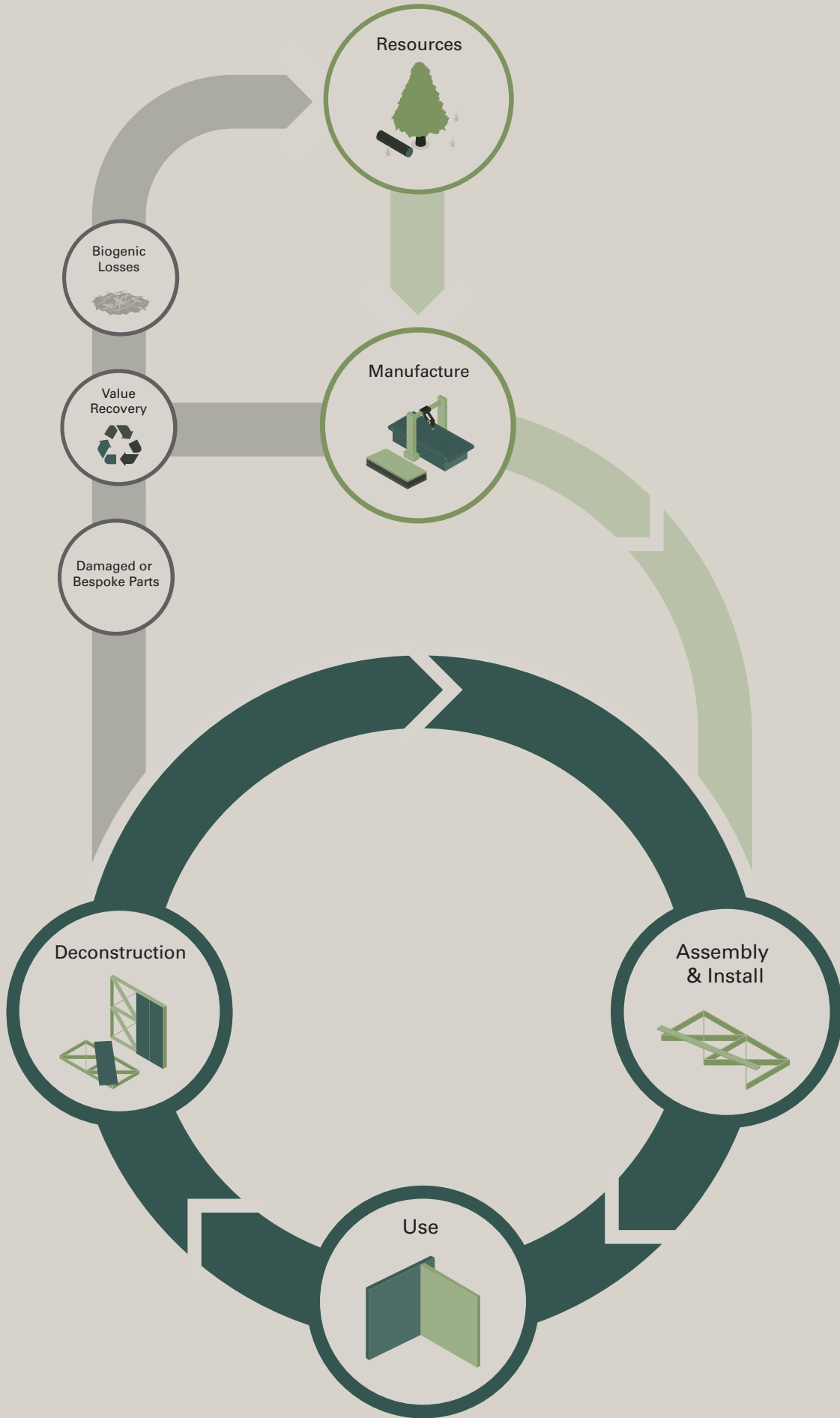

A framework for the circular economy in construction.

Unlocking Circularity

To achieve the ambition of a circular building industry it is the responsibility of architects and owners to adopt critical circular design ideas. The following ideas are essential to ensure circularity is effectively implemented. Overleaf are detailed criteria to guide decision making. These criteria should be used to review every material, product and system used in the building.



1. Do not compromise on material selection.

Material selection dictates how different building layers can be connected to one another and the type of material recovery possible at end-of-life. Using high quality non-composite materials means that reuse is more likely (as the material has more inherent value). Non-composite materials also have the benefit of being able to be recycled within clean high-value recovery schemes.



2. Standardise for future reuse.

Efforts to adopt standardised and interchangeable components on a large scale increases the likelihood of component reuse. The more similar components deployed, the higher the recovery value of those components. Rationalising wall lengths to industry standard sizes and separating bespoke architectural elements ensures that reuse is the most attractive end-of-life option.



3. Design in layers of change.

Every building component should be designed as a series of independent, interchangeable layers. These layers should never damage or compromise adjacent layers. Those most frequently modified should be easily removable in a damage-free manner. Any potential tertiary finishes or components that may limit the modification of these layers should be minimised.



4. Fixings dictate ease of deconstruction.

The methods used to connect secondary building elements to structural members must be easily reversible. These fixings also need to avoid damaging themselves, the elements they support and the members they fasten into. All adopted fixing systems need to be reversible by unskilled end-users and not impact the structural resilience of primary elements.

For further information refer to [Finch, 2019, 2021, 2023](#).

Buildings as Layers

Considering a building as a series of independent layers with different life-spans also helps with the practical implementation of circular design.

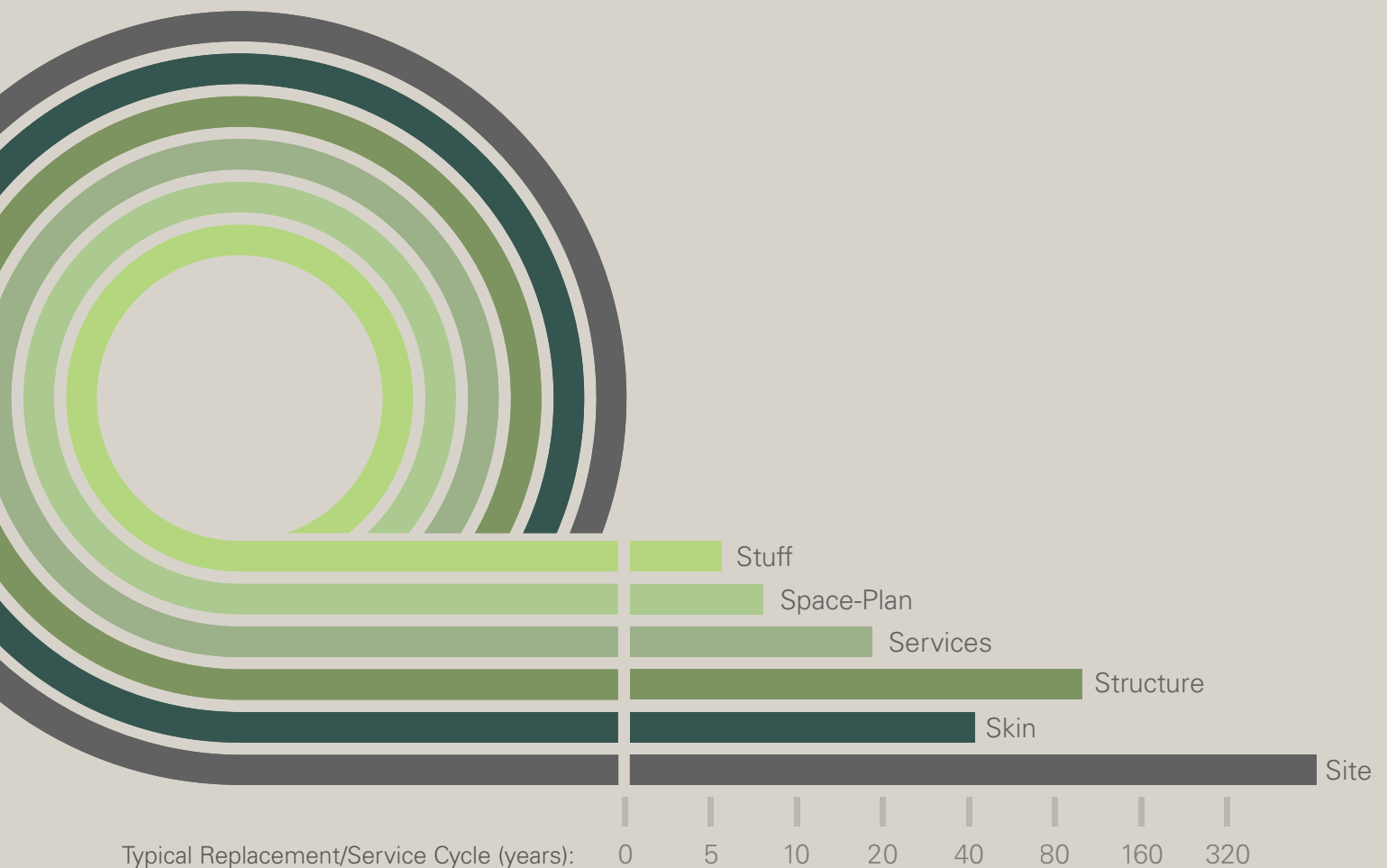

Primary layers to consider...

Site* (Ongoing)

- The site in which the building is located. The building's connection with the land, water and other built environment elements such as roading and public transport.

Skin* (~25-50 Years)

- Typically outside the scope of interior works. Building envelope layers including cladding (exterior visual elements) and secondary weathering layers (building wraps, cavity systems, external insulation and junction elements).

Structure* (~50-100 Years)

- Primary structural systems of buildings (including structural walls, structural columns, beams, structural flooring systems, lateral bracing elements and foundation systems).

Services (~15-25 Years)

- Various systems in the buildings, including mechanical, electrical and plumbing systems. The physical relationship of these items with structural and space-plan layers must be considered to achieve end-of-life recovery.

Space-Plan (~5-15 Years)

- Interior space elements that are fixed to the superstructure (wall finishes, ceiling finishes, floor finishes, internal non-load-bearing walls, suspended ceiling systems, raised floor systems, doorways, hallways, service walls).

Stuff (~0-5 Years)

- Objects in spaces that are either not fixed to the Space-Plan, or those that are fixed but easily removable. This may include furniture, storage items, supplies, vehicles and electronics.

Adapted from 'How Buildings Learn' | Buildings as Layers (Brand, 1994) * Not typically part of interior design actions.

Our Circular Economy Building Design Criteria

The following criteria should be used to evaluate the circular performance of each 'layer' or system adopted within a given design.

Lining	Insulation	Frame	Fixtures	Doors	Glazing	Services

Materials

- Recycled, reused, renewable and/or compostable feedstock
- Inert/non-toxic
- Non-composite/non-hybrid
- Without secondary finishes
- Low-carbon
- Durable
- Low embodied energy
- Established high-value material recovery schemes
- Limited quantities of different material types

Geometry

- Standardised module working through structural and finishing layers
- Component sizes that are easy to incorporate into new buildings
- Deconstruction possible in parts and/or as an entirety
- Manufactured using standardised material sizes
- Allows for flexible reuse through expansion/structural independence
- Sized to facilitate easy handling, transportation and storage
- Deconstruction sequencing apparent based on junction and module design
- Geometry such that it does not prohibit or limit deconstruction practices

Fixings

- Use of durable mechanical fixings that allow for multiple use cycles
- Fixings that do not damage the materials they join or themselves
- Standardised fixing positions across all reusable elements
- Fixings that can be quickly separated from intersecting materials
- Deployed fixings that can be removed progressively and safely
- Reduced numbers of connections in a unit area (lower is better)
- Fewer different types of connections in each layer (lower is better)

Documentation

- As-built documentation
- Standardised part auditing and reporting
- Lifecycle tracking of modified components
- A viable reverse logistics pathway
- Second-hand component validation/certification



Engineered Wood Products (EWP's) and the Circular Economy

The suitability of engineered softwood products as a material for circular construction should not be assumed. Although engineered timber relies largely on quickly renewable materials, there is also a need for petrochemically based adhesives to form a structural bond between wood layers¹. In many instances, it is also required that the engineered wood product be treated with chemical preservatives to increase resistance to rot and decay². The product's reliance on a non-renewable material and the inability of these non-renewable materials to be recovered from the product is not reflective of circular economy best practice.



Log Harvest
-14kg | +2.63

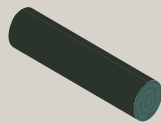

Veneering
+3.47



Resin
+2.29

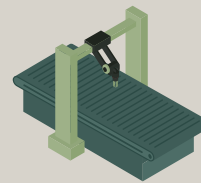

Pressing
+1.37

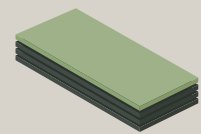

Packing
+0.03



Landfill (typical)
-0.05kg | +1.69



Energy Recovery
-8.84kg | +15.4



Reuse
-8.95kg | +14.0



Recycling
-2.41kg | +15.4

Life-cycle of Plywood | Adapted from Forest and Wood Products Australia Ltd EPD for Plywood (page. 18), 2022.
Values reported are the carbon footprint in kg CO₂-equivalent per m³ of 17 mm thick plywood including biogenic and fossil carbon.

There is a range of emerging timber adhesive and preservation technologies that are derived from renewable sources (lignin-based adhesives and thermal modification for wood preservation).^{3,4} The first of these bio-based adhesives were made available to New Zealand and Australian markets in 2020 (Plytech, 2020). Such technologies allow engineered wood products to fit more comfortably within a circular construction context.

1. Milner, H.R., and A.C. Woodard. 2016. "Sustainability of Engineered Wood Products." In *Sustainability of Construction Materials*, 159–80. Elsevier.
2. Shukla, S.R., and D.P. Kamdem. 2012. "Effect of Copper Based Preservatives Treatment of the Properties of Southern Pine LVL." *Construction and Building Materials* 34 (September): 593–601.
3. Aro, Matthew D., Brian K. Brashaw, and Patrick K. Donahue. 2014. "Mechanical and Physical Properties of Thermally Modified Plywood and Oriented Strand Board Panels." *Forest Products Journal* 64 (7–8): 281–89.
4. Wang, Sen, Yalan Yu, and Mingwei Di. 2018. "Green Modification of Corn Stalk Lignin and Preparation of Environmentally Friendly Lignin-Based Wood Adhesive." *Polymers* 10 (6): 631.



TROJAN FIRE

A2.

XFrame and the Circular Economy

XFrame is a prefabricated, lightweight engineered wall, floor and roof framing system that enables end-of-life recovery and reuse. XFrame is manufactured from sustainably sourced (FSC certified) structural plywood using precise computer controlled milling machines (CNC). The finished product is a series of modular parts that can be connected in many different configurations to form the required structural arrangement.



A kit of standard parts.



Made from natural and quickly renewable materials.



Requires only standard hand-tools.



Engineered, geometrically stable and scalable.



End-of-life flexibility via vertical modularity.



Eco-system design for effective circularity.



XFRAME™

XFrame Modular Circular Logic

The standard parts that make up XFrame structural panels allow for the creation of many different spatial configurations while using the same core set of parts. Horizontal and vertical modularity of the structural design ensures that standard parts will always be able to be adapted to meet new requirements.

The XFrame system is inherently laterally braced which allows lining materials to be clipped onto the structural frame in an easily demountable manner. The diagonally braced structural geometry means that all clip locations are standardised and precisely located. This means that standardised structural framing components always align with standardised prefabricated lining fixing points. These features eliminate damage of each element during assembly and disassembly processes – essentially unlocking the Circular Economy.

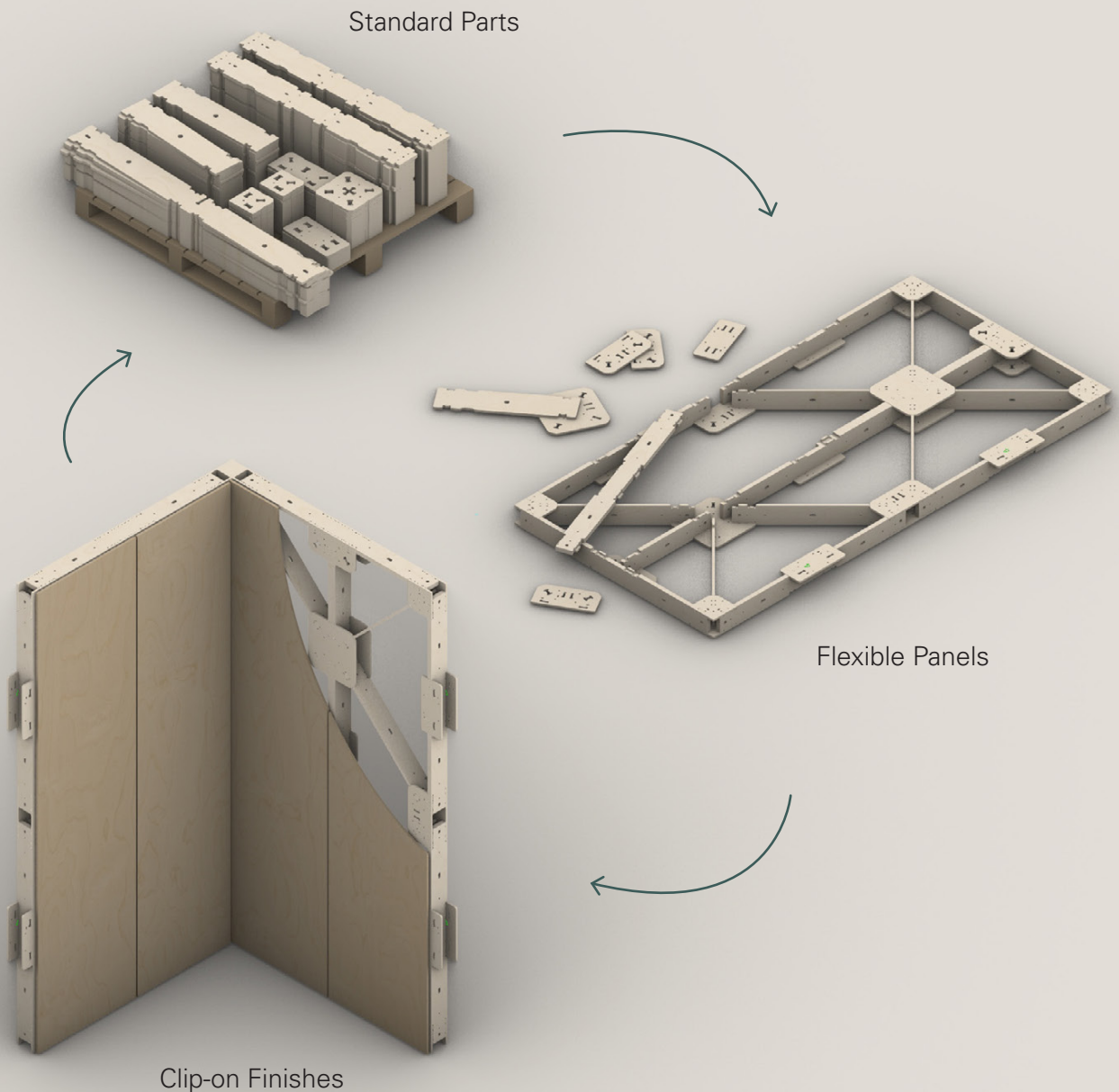

XFrame's Circular Feature-Set

Standardised

- × Typical wall frame panels use the same 8 standard parts (to create a 1200mm x 2400mm modular wall frame - 4ft x 8ft). The same standard parts can be used to create any panel size from 600mm square, to 3000mm high and 1200mm wide.
- × XFrame incorporates a demountable wall-lining fixing system that allows for any sheet product to be used, providing it is a minimum of 12mm / 1/2" in thickness. All wall linings can be standardised with reversible hiding fixing locations for these parts are pre-positioned on the XFrame. These reversible fixings points are reliable thanks to XFrame's self-braced and self-squaring structural geometry.
- × Custom height and width panels can be created on demand. These panels are made of as many standard members as possible. The design logic of XFrame means that custom requirements do not limit circular performance.

Efficient

- × 1200mm (4ft) wide XFrame panels use 20% less timber than typical stud walls.
- × Minimum 50% reduction in on-site assembly/install time for a finished unit of wall area (when compared to traditional timber framed walls with plasterboard linings).
- × Two-thirds faster to deconstruct than traditional timber framed walls while maintaining 95% material integrity (undamaged parts).
- × Minimum average 96% raw material utilisation (by weight).

Material Selection

- × Locally grown, harvested and manufactured *Pinus radiata* or Hoop Pine softwood plywood in all products manufactured in Australasia.
- × Exclusively Forrest Stewardship Council (FSC) certified timbers.
- × E0 formaldehyde emissions rated structural untreated engineered plywood.
- × All constituent materials covered by Environmental Product Declarations (EPD's).
- × Automated embodied carbon calculation and reporting at the time of design.
- × Integrated yield and waste monitoring reporting.
- × Low VOC insulation and panel finishes.
- × Framework for ISO 14001 compliance.

Reversible

- × XFrame facilitates the reversible fixing of interior wall linings via its predictable scalable fixing grid and reversible damage-free fixing hardware. The structural frame is not reliant on lining materials for bracing strength and therefore linings can be connected to the wall frame in an easily reversible manner.
- × XFrame panels are designed to be removable without affecting adjacent components. All panel-to-panel connections are durable multi-use structural fasteners, easily removed using standardised tools.
- × Frame wall-to-floor and wall-to-ceiling connections can be configured to best suit specific installations. Fixing quantities are always minimised, and damage-free solutions are available for floor fixing as required.
- × Modular planning options integrated into the XFrame system provides site-specific flexibility and ensures any component (wall, lining, roof-panel, corner post) can be removed without complexity or cascading consequences.

Industry Standard

- × Standard frame modules follow industry standard sheet sizes (600mm/1200mm). This results in better material utilisation and unit economics.
- × XFrame wall frame thicknesses follow industry standards (92mm and 140mm) meaning framing can abut standard dimensional timber framing as required. Modular demountable wall frames can be seamlessly integrated into existing fitouts.
- × Standard 'off-the-shelf' 1200mm x 2400mm wall-linings can be used with either shadow, lapped, concealed or butt-jointed edges.
- × Industry standard doorway opening sizes, window openings and architectural details are integrated into standard panel designs.



B1.

XFrame Interior Technical Design Guidance

Design is a critical part of creating circular buildings.

Making decisions during the design phase that are in alignment with circular construction methods results in more effortlessly circular structures. Section B1 outlines specific design decisions that enable XFrame to unlock circularity.



Modular Rules



Openings



Custom Parts



Linings



Acoustics

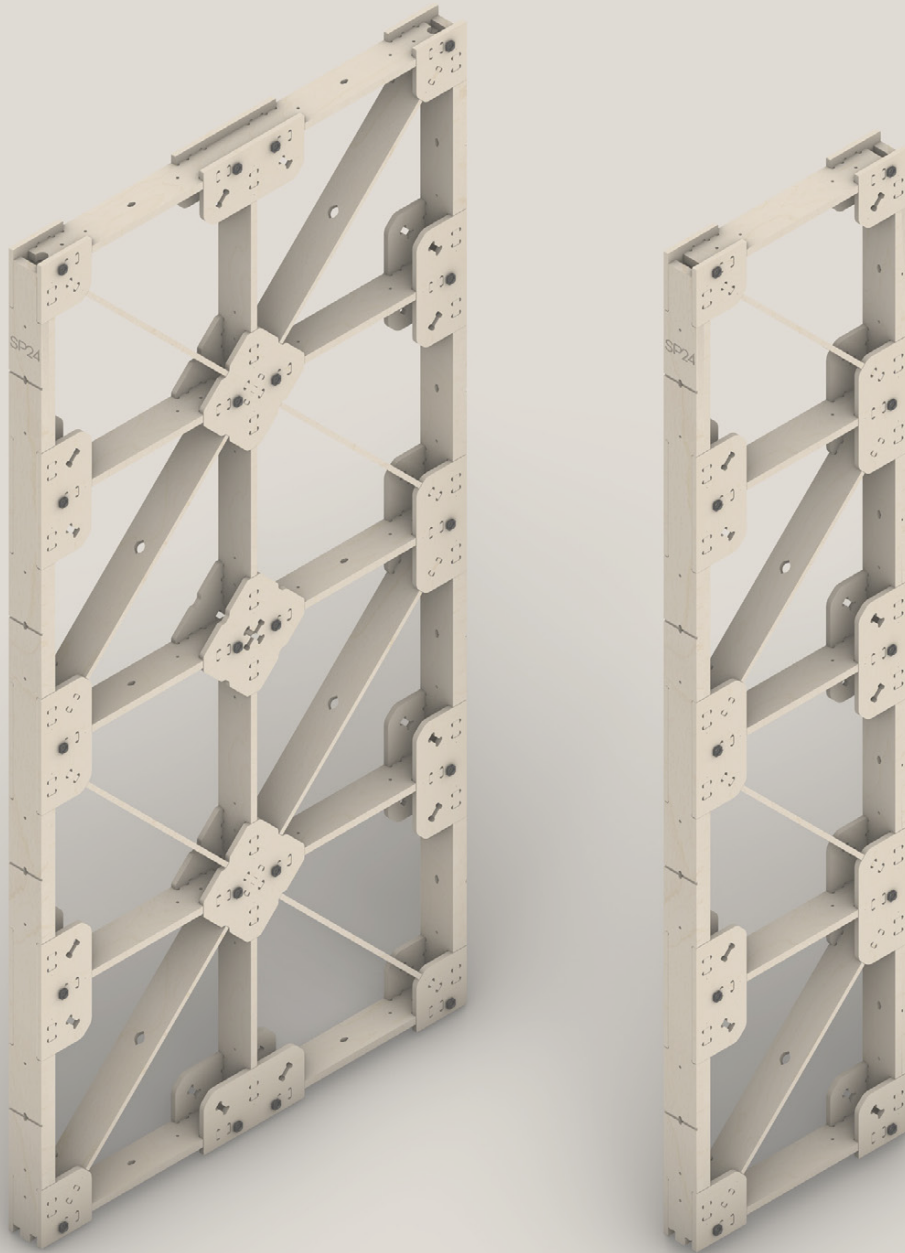

Standard XFrame Wall Panels (1200mm x 2400mm standard XFrame wall panel [left].
600mm x 2400mm standard XFrame wall panel [right]).

XFrame for Interior Settings

Interior fit-outs have comparatively short life-spans when compared to external walls and other primary load-bearing structural elements. Demountable and reconfigurable walling systems such as XFrame therefore make environmental and economic sense in such settings.

XFrame interior systems are highly suited to **office fitouts**, **retail fitouts**, **internal wall framing in low and high rise residential buildings** and for **event infrastructure**.

Typical Applications

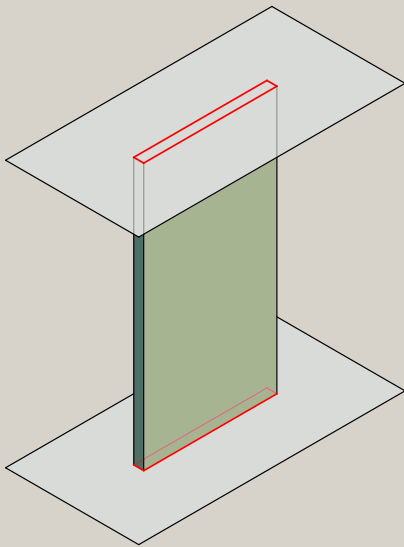

- × Full height (floor-to-ceiling) partitioning.

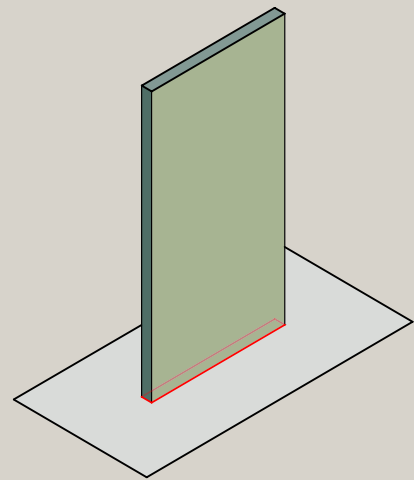

- × Cantilevered (floor fixed only) partitioning.

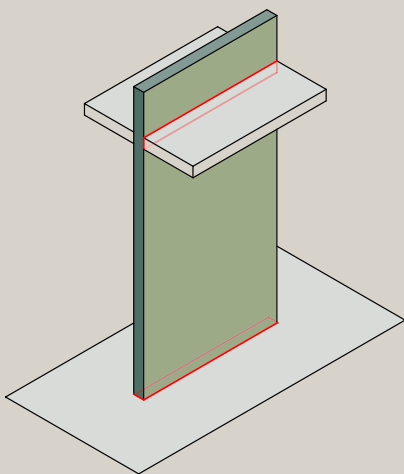

- × Enclosed free-standing spaces (cantilevered walls with XFrame modular roof framing).

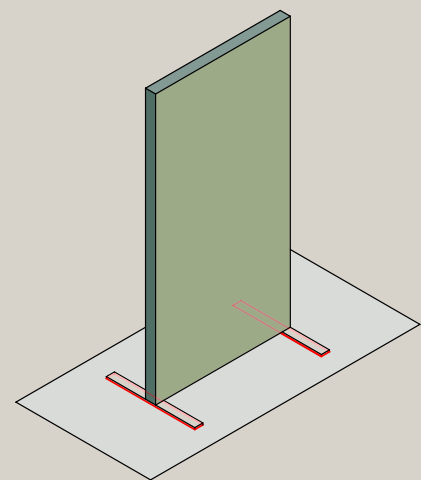

- × Temporary 'pop-up' walls for events, trade-shows, exhibitions and temporary retail.

Guidance Summary

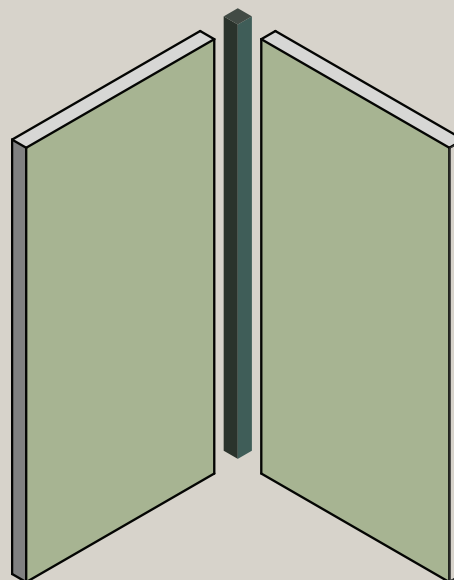
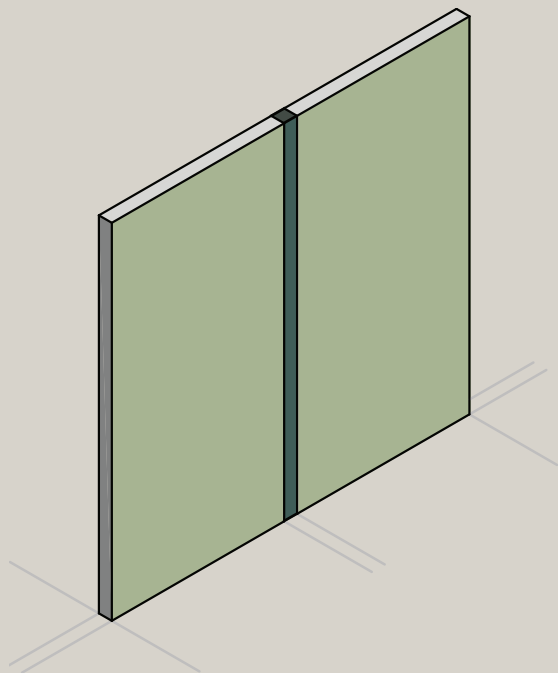

Adhere to a planning grid size and type

- × Ensure all walls follow a standardised modular length. For XFrame this should be multiples of 600mm.
- × When creating spaces of different heights work to follow industry standards (2400mm, 2700mm, 3000mm). This increases end-of-life utility value.
- × For more information see page 28.

Allow for modular corner and end rules

- × Ensure that any self-intersecting wall is detailed with either a corner post or is allowed to offset half the thickness of the wall.
- × The use of corner posts (corner modules) ensures more standard panel elements (frames and linings) can be used throughout a plan.
- × Any walls with open ends (not intersecting other walls or any other structures) are detailed with either a corner post, a structural capping or an additional length (50% of the wall's thickness).
- × For more information see page 32.

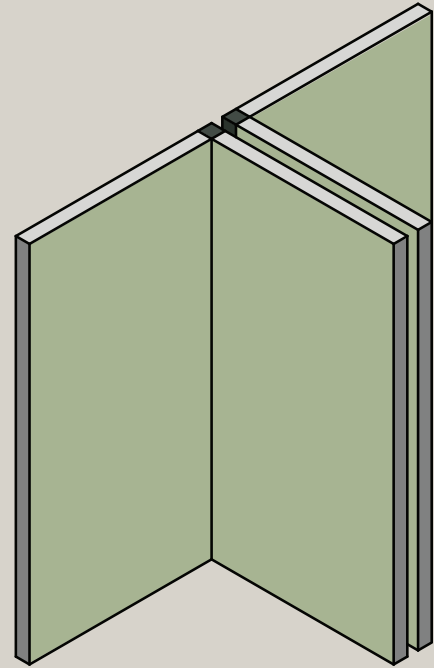
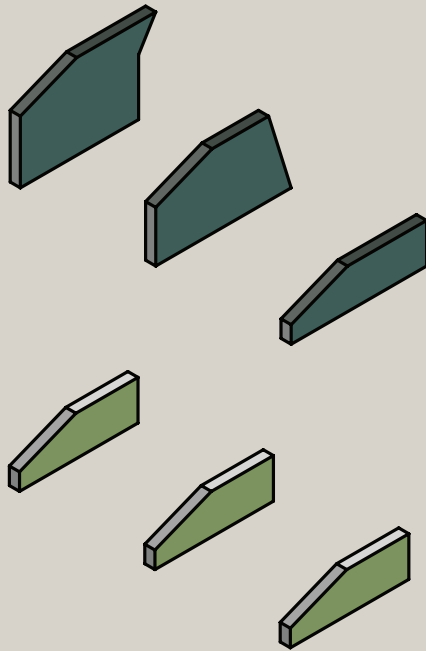

Use repeating custom decorative elements

- × Custom length wall sections, custom openings and bespoke angular members are expected. Where possible work to ensure any project specific custom members are reused throughout the design.
- × Reuse of custom elements improves the likelihood of component reuse and will decrease construction complexity.

Design for anticipated change

- × Evaluate what built elements will be most likely to be changed first and ensure they can be modified without impacting other building elements.
- × Double-walls can be an effective way of achieving excellent acoustic performance and ensuring future deconstruction can be completed quickly.
- × Limit the use of build-in furniture, plumbing or hard-wire electrical that may slow down deconstruction efforts.

Modular Rules

Following a standardised planning grid is critical to maximise the use of reusable interchangeable components. The greater the degree of component standardisation, the more easily those components can be reused.

XFrame follows a 600mm (or 2ft) module as standard.

- ✘ The designer should specify straight walls in increments of 600mm. If custom length elements are required these can be created by XFrame to suit. It is recommended that such custom length wall panels are standardised (reused) to reduce the number of custom components.

XFrame can be used in isolated, tartan and centre-line planning grids.

- ✘ Planning grid type is determined by project requirements. Refer to the diagram opposite to understand which grid type is most suitable for your project.

Isolated Planning

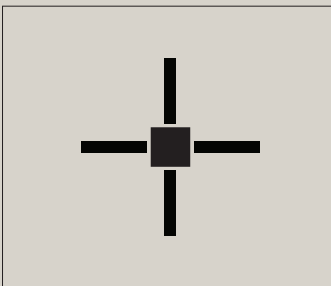

Isolated planning is suitable when wall sections do not intersect one another. This is common in buildings with elongated floor plates where walls run between primary structural members. Isolated planning results in highly standardised deployed components. When using isolated planning be aware of the following:

- ✘ Ceiling systems (if used) are matched to the wall panel grid.
- ✘ Ensure XFrame panels are appropriately terminated at their ends (see page 32).

Tartan Grid Planning

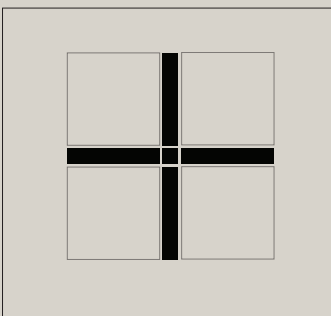

Tartan grid planning is ideal when creating simple repeating spaces of similar sizes. Tartan planning allows wall, roof and lining modules to be entirely standardised on the same base grid without the need for 'custom' corner offset finishes. As a result tartan grid planning can often be the most effective way to achieve modular standardisation in interior settings.

- ✘ Tartan grid planning uses 'corner posts'. These must be included in drawings.
- ✘ Do not use tartan grid planning in complex spatial settings that include many inconstant self-intersections.

Centre-line Grid Planning

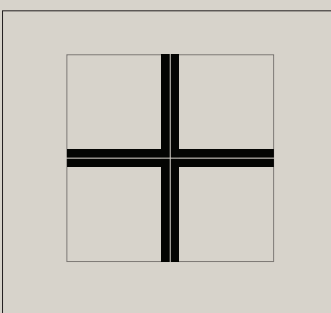

Centre-line grid planning is ideal for complex interior planning settings where wall panels frequently self-intersect. Centre-line planning uses 'long' and 'short' corners to ensure that the center of the wall always stays on a 600mm planning division. Centre-line planning introduces more custom components and should be avoided unless the floor plan cannot be easily simplified to use tartan grid planning. Centre-line planning is necessary when using a XFrame floor system.

🧩 Planning Grid Decision Matrix

Adopt a planning grid best suited to your project. Multiple approaches may apply to the same project in different zones. Please consult the XFrame design team for further guidance.

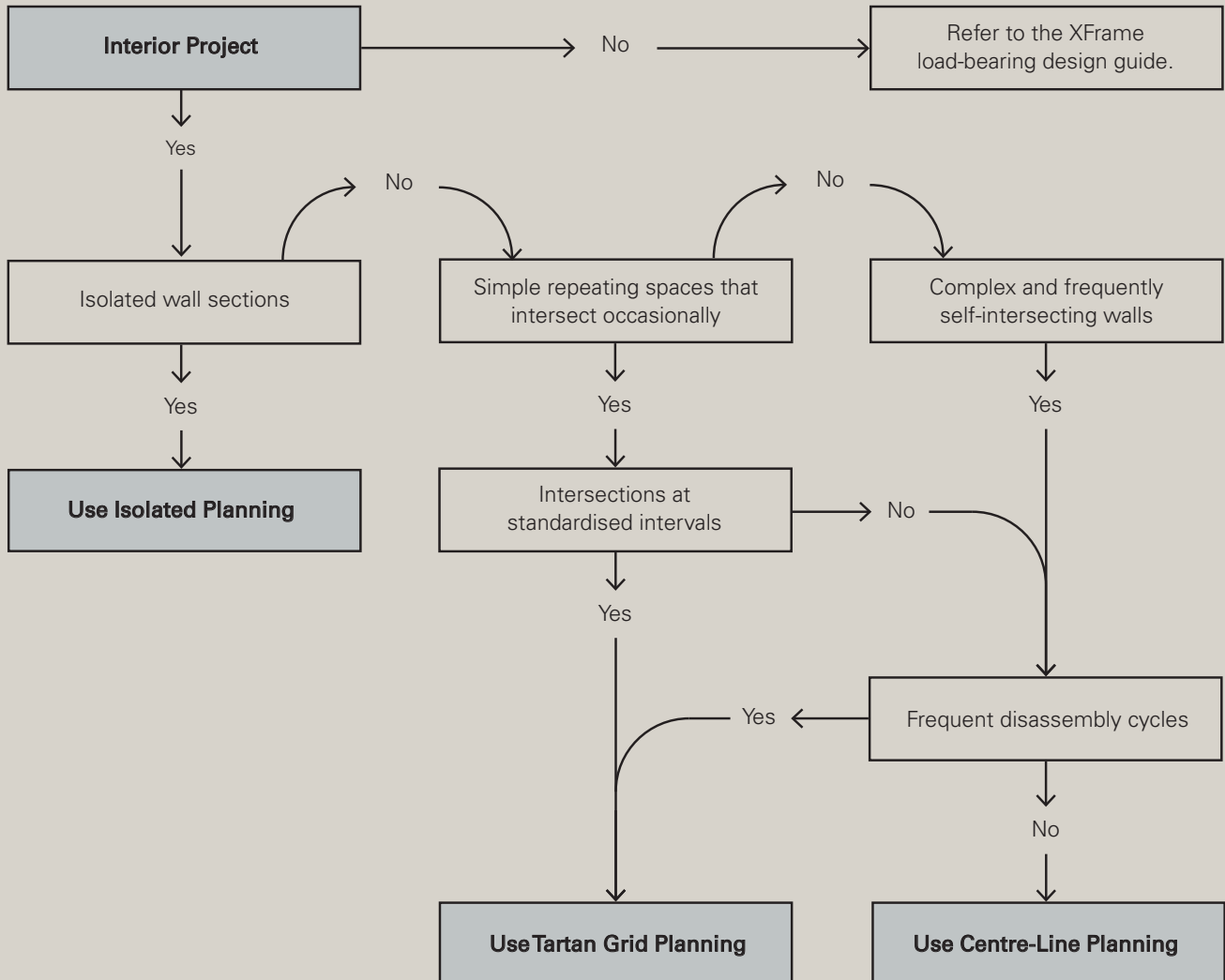

Our Advice...

In most instances '*isolated planning*' or '*tartan grid planning*' is the best modular planning approach for interior settings. These methods purposefully reduce the quantity of unique structural and finishing panels required.

These features make fabrication, installation and reuse less complex, decreasing costs and making reuse the more attractive option at end-of-life.



Examples of Grid Planning

Tartan Grid Planning

Standard 600mm modules forming walls with corner modules (black).
600mm grid resets at every intersection. Efficient for repeating linear plans.

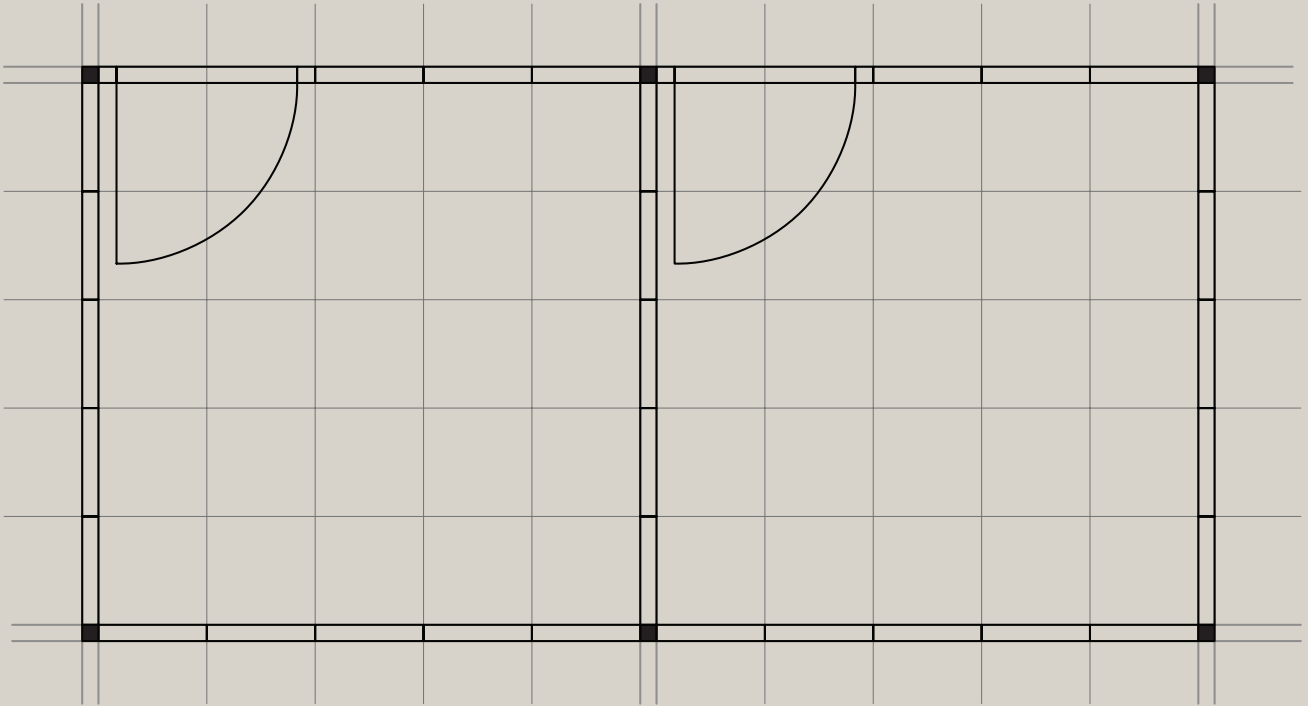

Centre-line Grid Planning

Panels with one elongated edge extend into each corner (light grey). 600mm grid resets at intersections in one direction only. Ideal for more complex plans.

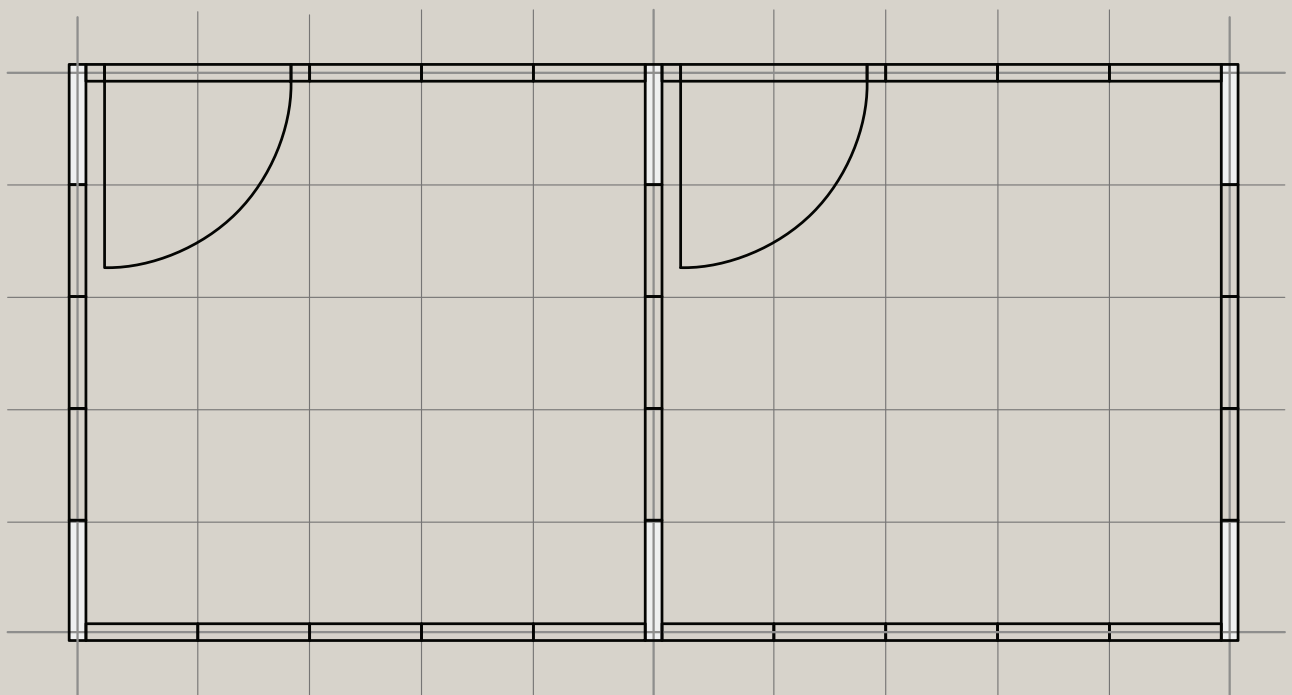

🧩 Modular Corners and Wall Ends

Tartan Grid Planning Corners

Tartan grid planning requires corner posts to be used. These corners are separate slender panels used to join intersecting elements at 90-degree increments (as standard). These panels can be rectangular and receive a 92mm wide (typical) clip-on/clip-off wall lining strip.

If desired further aesthetic options can be added for 90-degree corners. Adjacent linings can be extended over the corner post to reduce the appearance of frequent vertical modulation. Corner finishes can be mitered and folded to form crisp strong corner profiles. Some corners can also be curved to soften the modular feel of a given space.

Allow for Strong-ends

XFrame is designed to avoid redundant structural members. This means that when panels are joined their combined build-up works together to distribute loads.

Where a wall ends, and that wall does not intersect any other structural element, the end of the wall must be strengthened appropriately. The strengthening option may be changed depending on architectural requirements.

- × **Option 1:** Add an end capping made from structural plywood and bolted via concealed fixings to the primary structural frame.
- × **Option 2:** Add a modular corner post.
- × **Option 3:** Add a 'long-corner'/'strong-end' panel.

If the wall intersects another structural member no changes are required (no options above needed).

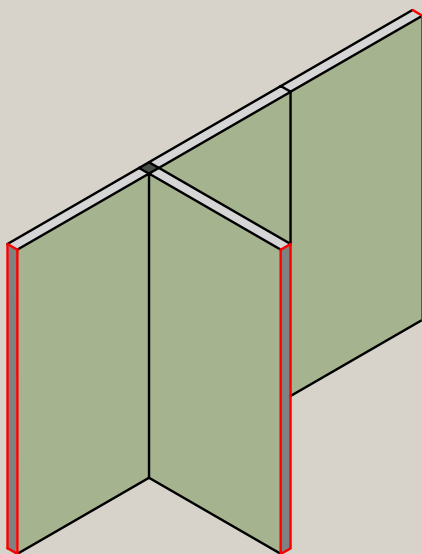

Unsupported 'Open-Ends'

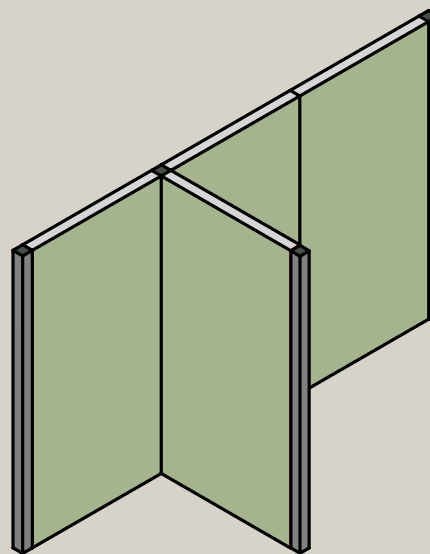

Posts or Structural Cappings

21mm structural plywood capping requires no post.



FIRE
EXTINGUISHER

Linings

The fixing grid built into XFrame is a core part of enabling easily demountable and reconfigurable interiors. Typical linings have center-points or a patented 'key-hole' shaped receptacle in their rear face. These alignment points allow linings to be clipped onto the structural frame in a precise and reversible manner.

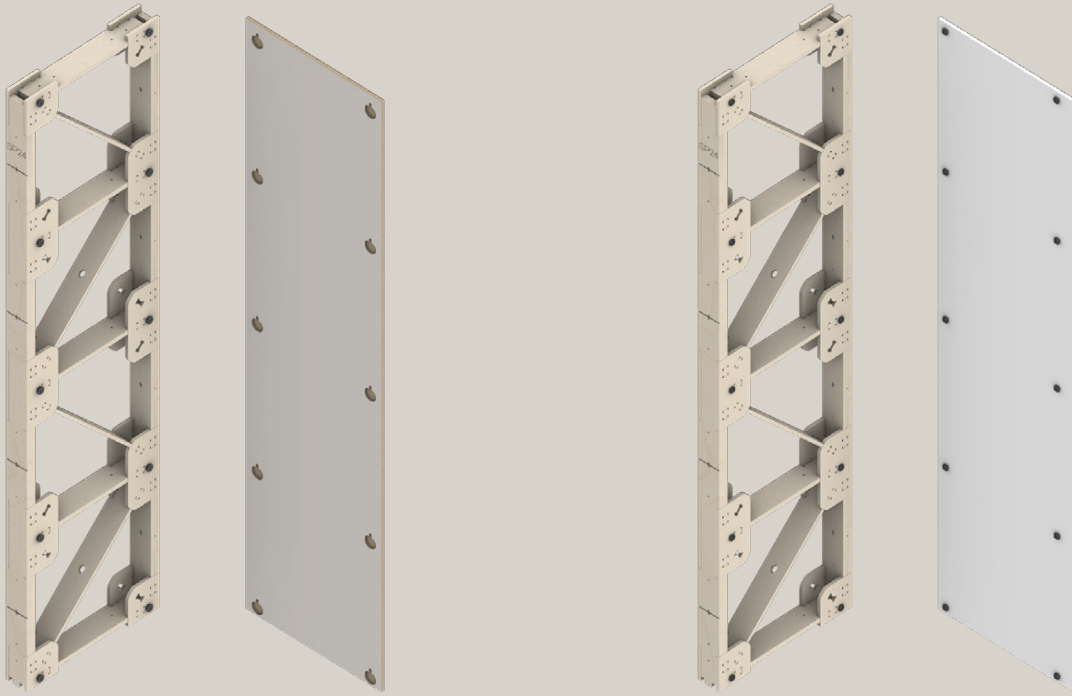

XFrame 010 System (PATENT PENDING)

- × Rapid on-site installation
- × No male clip required
- × Less prone to damage/more durable
- × 100% recycled post-consumer plastic

Fastmount VL-03

- × Ideal for PET, felt and other soft linings
- × Required for overhead linings
- × Excellent durability
- × Permits in-plane removal

Lining Material Specification

Any sheet lining material can be used with the XFrame system providing it has a minimum dense substrate of 12mm (1/2") or greater. Lining materials can be prefabricated by XFrame and supplied as a kit-of-parts with wall framing or product offerings. Non-prefabricated linings can also be fixed on-site. XFrame recommends reversible fixings in all use cases to ensure framing recovery can take place.

Lining Geometry Specification

Linings can be in sizes ranging from 600mm (2ft) square in 600mm (2ft) increments up to 1200mm x 3600mm (4ft x 12ft), or as materials and logistics allow. Sheets can be arranged vertically or horizontally. XFrame recommends 600mm wide panels as standard (2ft) for easier handling/reduced risk of damage.

Typical Lining Panel Geometry

Any split interval at 600mm divisions (vertically or horizontally) is possible while retaining full clip support. Shadow gaps between panels are set at 4mm by default. Clip locations are indicated in grey below.

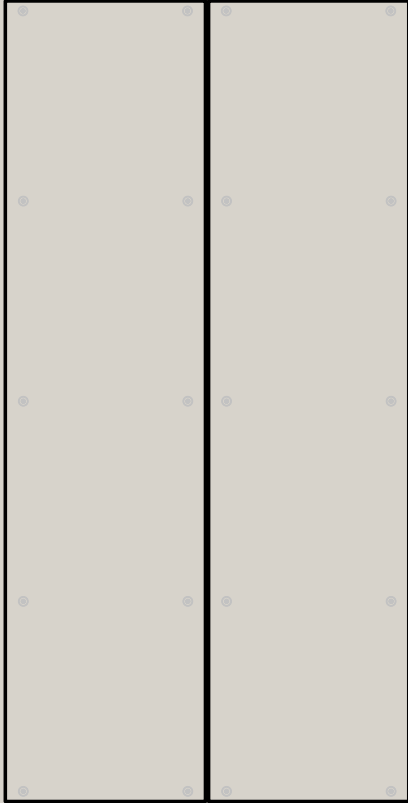

600mm wide vertical panels.



1200mm wide vertical panels.

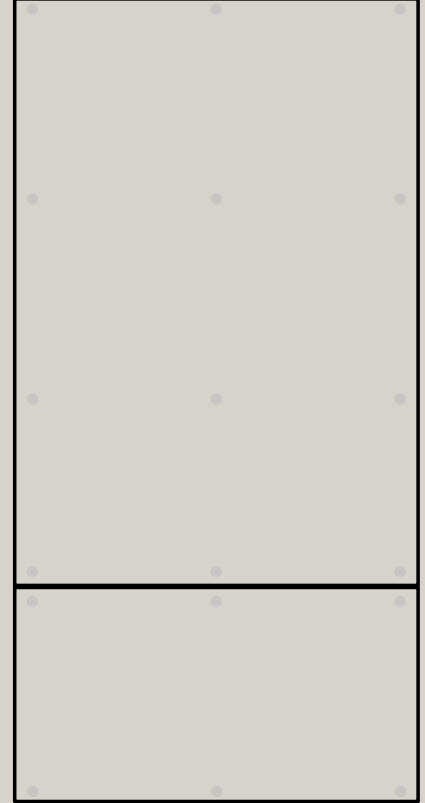

Horizontally split panels.

Lining panels can be directly abutted (no shadow gap), and/or arrayed across a wall with alternating split lines as required. Dark-coloured finishes can be used to minimise the visual presence of panel seams.

Openings

Door, window and service openings in XFrame modular wall panels can be specified as required. To improve the standardisation and interoperability of required opening's the following guidelines should be followed.

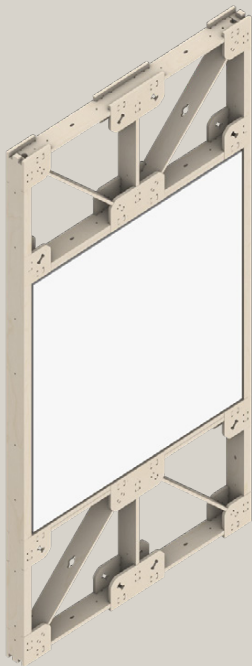

Snap opening size to nearest standard member

- × Allow 21mm of structural packing and 5mm of tolerance around all openings when snapping to standard members.
- × Consider the size of glazing panels based on safe lifting weight requirements.
- × Full-height (floor-to-ceiling) openings abutting standard panels are the most economical and standardised circular option.

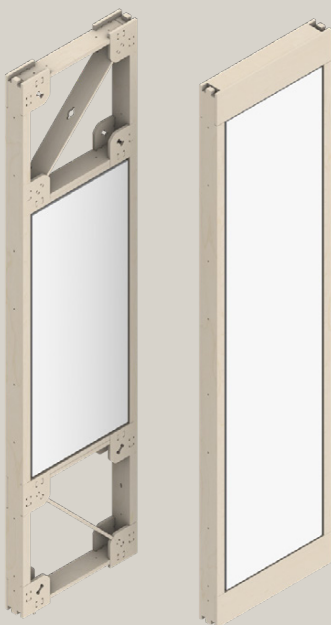

Manage custom size openings within same panels

- × Use the bounds of standard panels to create custom sized openings without adding modular complexity.
- × Leave space at the edges of panels between glazing and timber members for panel-to-panel connectors.
- × Consider how opening sizes effect lining configurations
- × Use timber reveals to limit the need for bespoke linings.

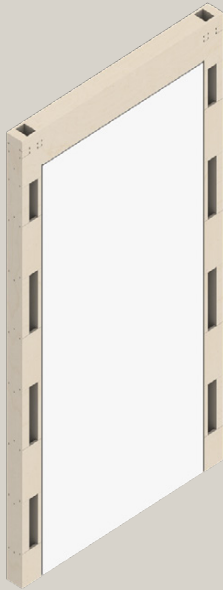

Adjustable door mounting wall panel

- × Adjustable door panel (1200mm wide and up to 2700mm high) bolts to standard wall frame panels.
- × Allows up to a 1000mm wide door to be installed. The most common opening size created is 960mm x 2100mm.
- × Creates void beside door for security and electrical cables that removes the need for drilling out nogs.



Full-height reduces cost and improves standardisation

- × Opting for doors or glazing systems that do not require overhead wall structures will improve standardisation rates across the project.
- × These types of openings also require less material, are faster to install, and can offer improved acoustics. Custom width XFrame panels can be added to make up any horizontal distance variations.

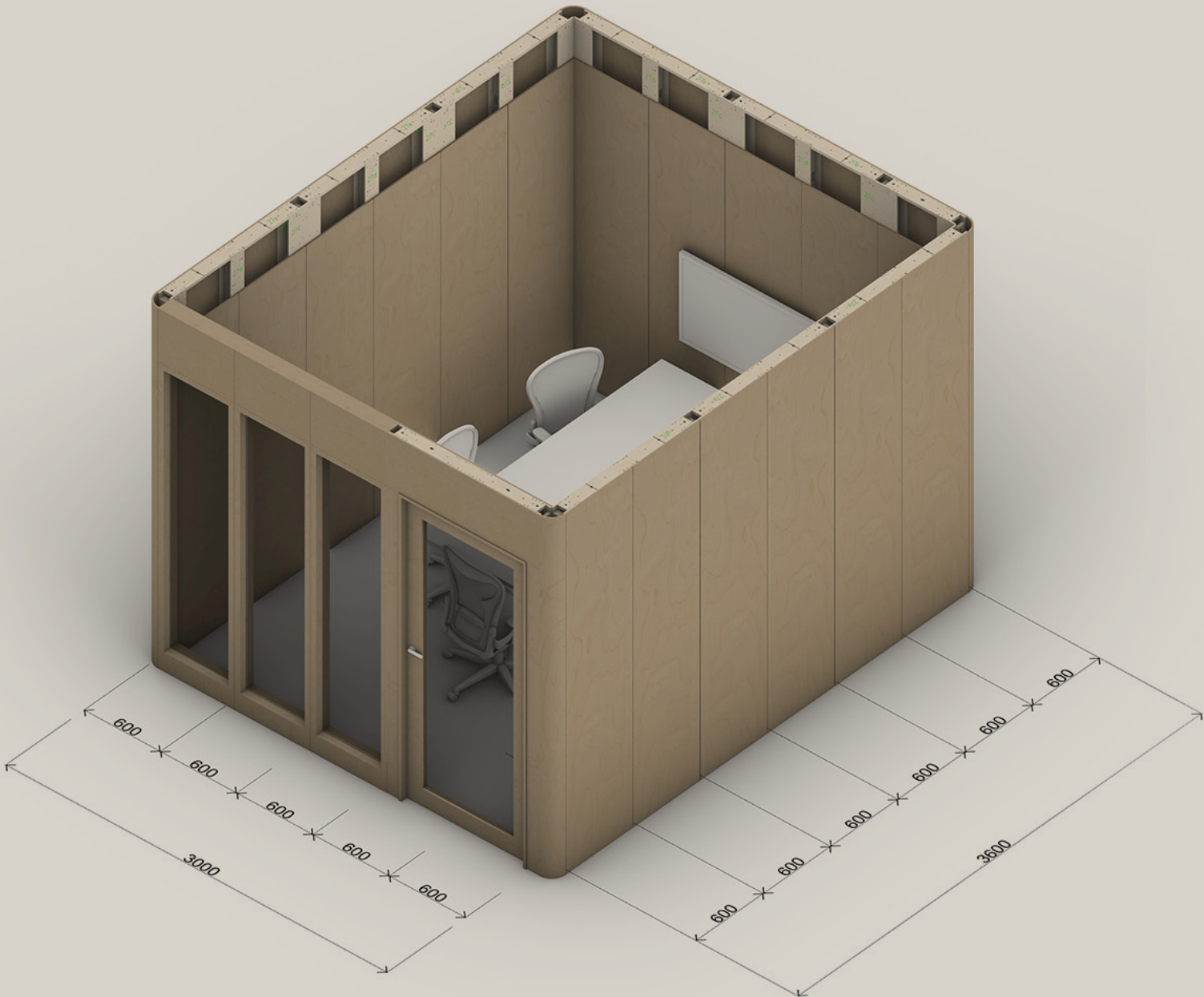
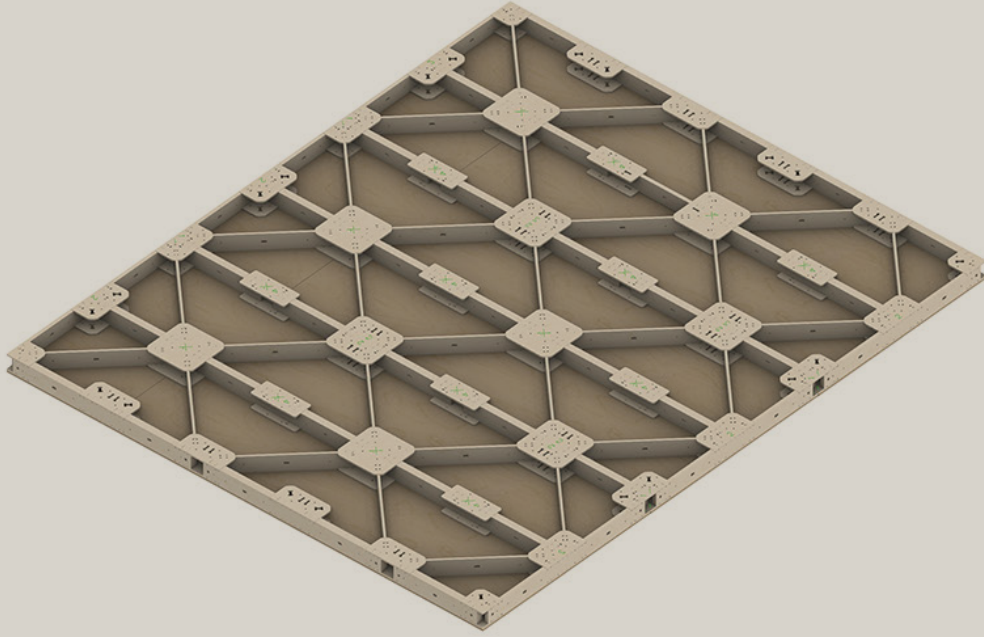

Acoustics

XFrame walls can be modified in different ways to increase the sound isolation performance. All methods centre around the principle of increasing a walls mass to prevent transmission of low frequency sounds. XFrame prioritises the use of acoustic control solutions that do not compromise deconstruction.

Indicative lining compositions for required acoustic levels...

- × STC <20 12mm PET felt lining only both sides with 50mm of cavity insulation.
- × STC 32 12mm PET felt + 12mm 400kg/m³ lining board with 50mm of cavity insulation.
- × STC 38 12mm 400kg/m³ lining board both sides with 50mm of cavity insulation.
- × STC 42 12mm 600kg/m³ lining board both sides with 50mm of cavity insulation & seals.
- × STC 45 16mm 600kg/m³ lining board both sides with 50mm of cavity insulation & seals.
- × STC 50+ 3x 12mm 600kg/m³ lining board both sides with 50mm of cavity insulation & seals.

Flexible acoustic barrier (FAB) and resilient rail configurations are also possible. Testing, report and simulation data available on request.

Recommended acoustic separation levels...

- × Offices to Corridors: 40 STC
- × Standard Offices 40 - 45 STC
- × Private Offices: 45 - 50 STC
- × Sensitive Areas: 50+ STC



C1.

Engaging with XFrame

Design Phase (see detailed process on page 42).

Client Design

Clients nominated design professional create a design and pass this information across to XFrame. XFrame provides comment to improve circular performance of the proposed design and an initial cost estimate.



Tender and Detailed Design

Concept design progressed to tender phase. All required spatial and material specification information are supplied to XFrame. XFrame supplies basic drawings to indicate extent of XFrame in the project in tender submission.

Delivery Phase (see detailed process on page 43).

Manufacturing and Assembly

After acceptance of a tender, XFrame will generate relevant prefabrication information and work with a nominated pre-approved fabricator to create/dispatch the required components. This includes ordering of required project, pre-assembly of panels and completion of required test-fits.

XF Delivery Partner



Delivery and Installation

XFrame will arrange delivery to the project address. A pre-approved installer contracted by XFrame will complete on-site installation, or, installation will take place via a 3rd party installer, such as the project's primary general contractor, or a sub-contracted carpentry team.

XF and/or Partner

XFrame Design Process

1. Architect/designer designs spaces to meet project specific requirements.
 - ✦ The architect/designer can draw elements in a conventional manner (i.e., using standard BIM wall families and/or 2D CAD). Alternatively XFrame's Revit Family can be used which aids in adherence to the modular conditions of XFrame.
2. Architect/designer consults this technical guide to ensure the proposed designs compliance with circular design requirements and compatibility with the XFrame system (see B1).
3. Architect/designer consults XFrame if any technical or planning questions arise that are specific to a given project (email projects@xframe.com.au).
4. Architect/designer/client sends project geometry to XFrame for a no-obligation estimate.
 - ✦ If XFrame's Revit family was used, the user should run the XFrame Dynamo export tool and send XFrame the relevant outputs.
 - ✦ XFrame can accept the following information to produce an estimate:
 - » An annotated and scaled PDF plan with elevations (or stipulated wall heights).
 - » .dwg or .dxf 1:1 scaled drawing with annotations.
 - » A 3D BIM model exported in a industry exchange format.
 - » Via the XFrame Revit family export.
 - » If none of the above means are possible please contact XFrame.
 - ✦ In all instances it is critical that wall height, material finishes and required acoustic transmission performance is stipulated.
 - ✦ XFrame can accept the designs of buildings/spaces not optimized for XFrame integration. Such designs will take longer to process and can be adjusted by XFrame to better align with standardised elements if requested. If no standardisation is requested this typically results in the requirement for many custom wall framing members.
5. XFrame processes the design into XFrame components and supplies an estimate and provides a detailed list of limitations based on supplied information and XFrames degree of involvement.
6. Estimates are sent to the architect/designer/client for review.
7. Further estimates can be created on a project-by-project basis depending on design options, project complexity and value engineering.
8. Additional work requires formal engagement with XFrame.
9. If requested, XFrame or XFrame licensees, will submit a tender (or support the tender of a third party) for work of a defined scope that incorporates XFrame.

XFrame Project Delivery Process

1. After acceptance of a tender XFrame will generate relevant prefabrication information and work with a nominated pre-approved fabricator to create/dispatch the required components.
 - × Depending on the scope of engagement XFrame and its fabricators will:
 - » Source relevant materials, fixings, speciality hardware and finishes.
 - » Coordinate and carry out primary prefabrication activities, including milling, assembly and factory finishes.
 - » Arrange dispatch to site and/or a nominated location.
 - × If agreed, a pre-approved installer contracted by XFrame will complete on-site installation.
 - × If agreed, installation will take place via a 3rd party installer, such as the project's primary general contractor, or a sub-contracted carpentry team. In this installation process additional documentation outlining quality control hold-points will be supplied to the installation contractor.
 - × The delivery of XFrame components to site may be split into multiple deliveries depending on the type of project and any pre-arranged and agreed delivery schedule.
 - × Installers are required to complete XFrame supplied sign-off documentation.
2. XFrame will arrange engineering approval for its scope of works as soon as the design is confirmed.
3. XFrame will create project specific shop drawings to supplement standardised installation documentation and issue these prior to dispatch of components.
 - × Documentation issued by XFrame as standard includes:
 - » An itemised packing list of all dispatched components.
 - » Project specific engineering compliance documentation.
 - » Panel assembly information to the nominated pre-approved fabricator.
 - » On-site installation information (assembly sequencing, assembly referencing for finishes and other prefabricated components).
 - » Shop drawings for consent and integration/coordination.
4. Variations to the agreed scope-of-works during the delivery phase of the project are required to be submitted in writing to XFrame (or the nominated pre-approved fabricator) and will approved on a case-by-case basis.



Certification and Compliance Pathways

1. New Zealand

- × For large fit-out projects that require a building consent XFrame will work with a regional engineer to prepare a Producer Statement (PS1).
- × To streamline the consenting process and the timing of relevant contracts XFrame can also be added to a consent via a minor variation. Relevant XFrame PS1 documentation can be submitted as part of the variation.
- × Please engage XFrame as early as possible to ensure relevant documentation can be prepared in a timely manner.

2. Australia

- × When a consent is required or use of XFrame falls outside of standard design scope, XFrame will work with an engineer to prepare relevant supporting documentation.
- × XFrame will supply State/Territory specific sign-off documentation on a case-by-case basis.

XFrame Interior Technical Specification

	Furniture System		Interior Wall Frame System	
	Modular free-standing applications such as desk dividers, single, double and four person meeting rooms/booths for office, workplace, retail and education.		Partition walls for commercial, residential, educational and retail use cases.	
Standard Module	525mm	1 3/4 ft	600mm	2 ft
Efficient Module	1050mm	3 1/2 ft	1200mm	4 ft
Depth	98mm	3.85"	92mm / 4" & 140mm / 6"	
Weight	13.5kg	30 lb	16kg	36 lb
	for a standard 2100mm x 1050mm unlined birch framed panel		for a standard 2400mm x 1200mm unlined pine framed panel	
Frame material	FSC and/or PEFC Hoop Pine Ply		FSC and/or PEFC Structural Untreated Pine Ply	
Loading capacity	Non-structural		11KN/m Axial, 60 BU/M unlined (lateral) and 1kN/2.4m face-loading	
Panel joining	M6 30mm JCB/JCN		M6 90mm Hex Head ZP Bolt	
Single span limit	2050mm 7 ft		3000mm 10 ft	
Lining support	475mm (18") centers for pressure clips		580mm (22") centers for pressure clips	



XFRAME



Wellington, New Zealand



Adelaide, Australia

Copyright XFrame PTY Ltd 2023 | www.xframe.com.au

'XFrame' and the XFrame logo are registered trademarks of XFrame PTY Ltd.

All technical information supplied here-within should be verified by independent professionals and/or XFrame.