

OPTIMIX

2G 40-250

2G 90-280

2G 90-380

2G 110-280

2G 110-380

2G 150-380

Application

Submersible motor
 Dry matter content up to 12 %
 Substrate temperature up to 55°C
 pH-value 6.5 - 8.2

Motor

Motor power: 4.0 / 9.0 / 11.0 / 15.0 kW
 400 V, 50 Hz, special tension on request
 Protection class IP 68, up to 10 m submergence
 PTC thermistors for thermal protection
 High efficiency
 Own oil circulation, turbine oil

Gear

Flange mounted planetary gear,
 reduction ratio $i = 3.83 / 5.25$
 Own oil circulation, longlife gear oil
 Change oil after 10,000 operating hours
 or 4,000 operating hours for 2G 150 - 380

Corrosion protection

Ductile cast iron housing (GGG40)
 Agitator has a two component epoxy coating
 Agitator is galvanically isolated from the guide mast

Electric Cable

Pressed-on cable gland
 Standard length 10 m
 $7 \times 4 + 4 \times 1.5 \text{ mm}^2$, $\varnothing 20 \text{ mm}$
 Resistant against biomass
 Strain relief 800 N

Propeller

3-blade high efficiency propeller, dynamically balanced

Optimix 2G	4 kW	propeller HD+ 620	250 rpm
Optimix 2G	9 kW	propeller HD+ 750	280 rpm
Optimix 2G	9 kW	propeller HD+ 580	380 rpm
Optimix 2G	11 kW	propeller HD+ 820	280 rpm
Optimix 2G	11 kW	propeller Hd+ 620	380 rpm
Optimix 2G	15 kW	propeller HD+ 660	380 rpm

Hardened steel, ss304 or galvanized

Guide mast connection

Guide mast support with 4 rollers for smooth height adjustment:

for 4 / 9 kW: 80 / 100 / 120 mm square mast
 for 11 / 15 kW: 100 / 120 / 150 mm square mast

Bearing

Bearing flange with mechanical seal SiC/SiC
 2 tapered roller bearings to absorb the axial forces
 Shaft of hardened steel
 Bearing flange with separate oil chamber filled with longlife gear oil
Accessory: POM protection to minimize abrasion

Ex-Zone

Authorized for Ex-Zone 2
 ATEX Classification **CE** **Ex** II 3G Ex ec h IIA T3 Gc

Control box

9, 11 and 15 kW: Star-delta switch, soft start or frequency converter
 4 kW: Direct start*, star-delta switch, soft start or frequency converter

* only after consultation and approval!

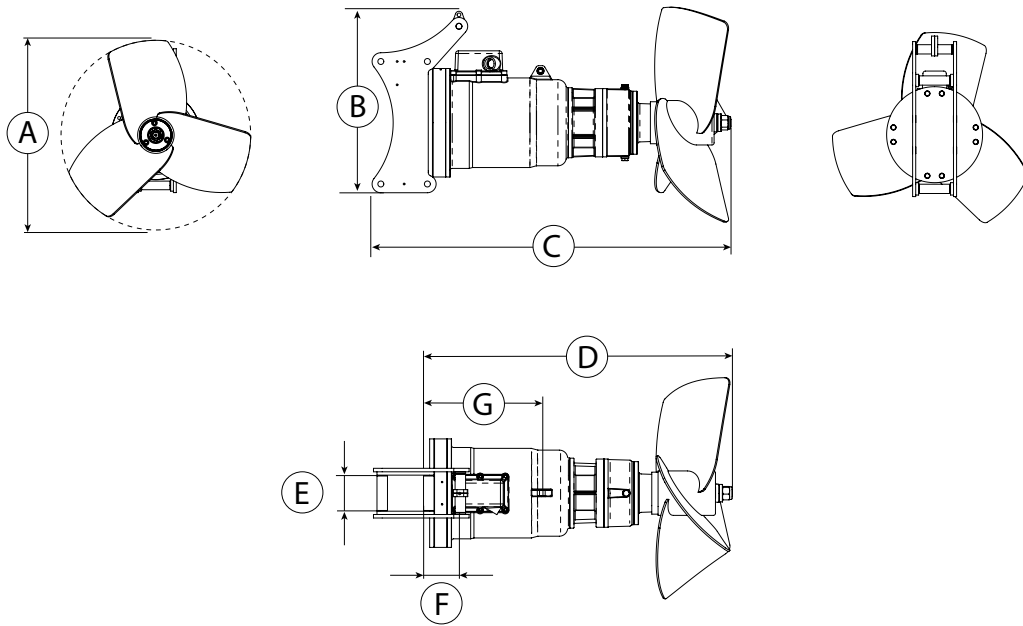

OPTIMIX

2G 40-250
2G 90-280
2G 90-380
2G 110-280
2G 110-380

Dimensions / Weight

Type	A [∅ in mm]	B [mm]	C [mm]	D [mm]	E [mm]	F [mm]	G [mm]	Weight approx. [kg]			
2G 40-250	620	520	1,050	855	80 / 100 / 120	105	305	170			
2G 90-280	750	520	1,085	885	80 / 100 / 120	105	300	170			
2G 90-380	580	520	1,050	850	80 / 100 / 120	105	300	170			
2G 110-280	820	520	1,100	900	100 / 120 / 150	105	335	180			
2G 110-380	620	520	1,100	900	100 / 120 / 150	105	335	180			
2G 150-380	660	520	1,100	900	100 / 120 / 150	105	335	180			

Technical data

Type	Rated Power [kW]	Rated Voltage [V]	Full load current [A]	Frequency [Hz]	Power factor cos φ	Gear reduction ratio	Propeller speed [rpm]	Propeller diameter [mm]	Axial force [kN]	Flow velocity [m/s] *	Pumping rate [m³/min]	Pumping rate [m³/h]
2G 40-250	4.0	400	8.8	50	0.77	3.83	250	620	0.95	2.2	38	2,290
2G 90-280	9.0	400	17.7	50	0.83	5.25	280	750	2.4	2.9	75	4,480
2G 90-380	9.0	400	17.7	50	0.83	3.83	380	580	1.9	3.4	51	3,080
2G 110-280	11.0	400	22.5	50	0.77	5.25	280	820	3.6	4.1	128	7,680
2G 110-380	11.0	400	22.5	50	0.77	3.83	380	620	2.55	3.7	64	3,850
2G 150-380	15.0	400	29.1	50	0.83	3.83	380	660	3.1	4.1	80	4,860

Subject to technical changes
 * measured in water and 1.2 m distance