

**Machine for bevelling of edges with variable angle  
and automatic feed**

## **UZ30 Express**



**Operation & Maintenance Manual**



A copy of this manual is supplied with every UZ30 Express edge bevelling machine model. All rights reserved.  
 No part of this publication may be reproduced without the previous consent granted by the company N.KO.

## Contents

<b>1</b>	<b>General information</b>	
	Introduction	3
	Tests	3
	Guarantee	3
	Identification data	4
	Reference standards	5
<b>2</b>	<b>Safety</b>	
	Safety tips	6
	Safety stickers	7
	Qualification and protection of operating staff	7
	Safety equipment	8
	Residual risks	9
<b>3</b>	<b>Technical specification</b>	
	Machine description	9
	Technical specification	10
	Noise level	11
	Conditions of work environment	11
<b>4</b>	<b>Installation</b>	
	Transport and lifting	11
	Installation and connection	12
	Checks before commissioning	14
	Destruction and disposal	14
<b>5</b>	<b>Use</b>	
	Proper use	15
	Description of controls	15
	Presetting	17
	Setting of reduction size and cutting conditions	20
	Machining	23
<b>6</b>	<b>Maintenance and adjustment</b>	
	Recommendation	24
	Demounting of the milling head	24
	Exchange or turning of indexable inserts	27
	Lubrication	28
	Table height calibration	29
<b>7</b>	<b>Accessories</b>	
	Added tables	29
	Fixture for pipe bevelling	31
<b>8</b>	<b>Spare parts</b>	
	How to order spare parts	32
	Wear parts	33
	Wiring diagram	33-34
	Spare parts drawing scheme	35-40

## **General information**

### **1.1 Introduction**

Thank you for purchasing one of our machines, and we hope that you will be fully satisfied.

This guide provides instructions for the installation, adjustment, operation and maintenance of the machine

**UZ30 Express** (the "UZ30" hereinafter ) in accordance with the applicable safety standards.

**The information and data contained in this document subject to changes due to further improvement of machinery. To eliminate any doubts, when differences are detected, please contact N.KO.**

Never perform any operation on the machine before you read the instructions in the manual and understand them. Major part of accidents that happen in the workplace are due to the fact that the guidelines and recommendations contained in the manual are not complied with.

The graphic symbols used in the manual are intended to emphasize the important information regarding the safety and operation of the machine.



**Caution:**

**Information important for the personal safety of the operating staff.**



**Important:**

**Instruction that needs to be observed to ensure the proper function of the machine.**

### **1.2 Tests**

The machine for edges bevelling is tested in our test room.

During that test, the correct function of the electrical system, as well as the right function of bevelling sheets and profiles by different types and sizes, are tested.

### **1.3 Guarantee**

The UZ30 is provided by the seller with a guarantee that the article shall not feature any material and production defects for a period of 12 months following the delivery date.

The machine is provided with a 12-months' guarantee from the delivery date for the faultless function of the article and the materials used.

The seller undertakes to make sure that any potential warranty defects are removed free of charge and without undue delay so that the buyer is able to use the article the way they desire. Should the buyer claim liability for warranty-unrelated defects, it shall reimburse the seller for any expenses associated with that.

The warranty period does not run from the date the buyer reports to the seller the existence of a defect covered by the warranty, which does not allow the buyer to use the article and assert its rights from liability for defects of the provided guarantee up to the date of its removal by the seller.

The warranty does not cover natural and normal wear and tear and defects caused by improper use of the article in violation with the provided training and documentation. This guarantee does not further cover defects caused by overloading of the article, or defects occurred after any improper interference in the article, or improper repair or modification of the article. Tampering, repair or modification means any intervention, repair or modification that was made in contradiction with the provided training and documentation, or was made by a person other than the seller, or a person authorised or approved by the seller.

Any rights from liability for defects from the provided warranty must be filed at the seller without undue delay after the buyer discovers a defect, but no later than by the end of the warranty period, otherwise the rights will expire.

To exercise the rights from liability for defects of the provided warranty the buyer must submit the warranty certificate. Otherwise, the buyer cannot be assigned these rights.

The Seller's liability for defects covered by the guarantee does not arise if these defects were caused after the risk of damage to the article due external events was transferred. External events are, in particular, natural disaster, force majeure event, or conduct of third parties.

N.KO. considers the guarantee invalid if:

- the machine is improperly used;
- used in conflict with national or international standards;
- improper installation;
- defective power supply;
- severe shortcomings in maintenance;
- unauthorised modifications or interventions;
- other than the original or wrong spare parts and accessories are used for that model;
- full or partial failure to follow the instructions;
- extraordinary events, natural disasters or the like.

#### **1.4 Identification data**

The identification data on machines for edge bevelling are listed on the CE aluminium plate affixed to the side of the machine.

## 1.5 Reference standards (CE Declaration of Conformity)

### CE Declaration of Conformity

1. Name of Declaration issuer: N.KO spol. s r.o.  
Adresa vydavatele prohlášení: Tábořská 398/22, 293 01 Mladá Boleslav  
ID No.: 26161109
2. Subject of Declaration:  
Name: MOBILE BEVELLING MACHINE  
Type: UZ 30 Express  
Manufacturer: N.KO spol. s r.o.
3. Purpose of use: stationary automatic bevelling system for chamfering of small and medium steel pieces
4. The above described subject of Declaration complies with the requirements of the below documents:
- |                            |  |
|----------------------------|--|
| Directive No. 2006/95/EC:  | General technical requirements for low voltage electrical equipment  |
| Directive No. 2004/108/EC: | Electromagnetic compatibility  |
| Directive No. 2006/42/EC:  | Safety of machinery - General requirements   |
| EN ISO 12100.:             | Safety of machinery - Technical principles of designing  |
| EN ISO 13857.:             | Safety of machinery - Safe distances for upper and lower extremities   |
| EN 953 al:                 | Safety of machinery - Requirements for construction of protective covers   |
| EN 60204-1:                | Safety of machinery - Electrical equipment of work machines  |
| EN 61000-6-3:              | Electromagnetic compatibility - Generic standards - Emissions - Residential, commercial and light industry environment |
5. Data on certified / notified entity:  
-----
6. Date and place of issue: 19.8.2016 Mladá Boleslav  
7. Name and role of authorised person: Milan Richtř - Executive Agent

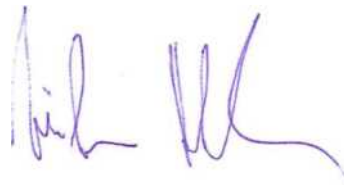

## SAFETY

### 2.1 Safety tips



#### **Caution:**

**Get thoroughly familiar with the following instructions to prevent personal injuries and/or damage to property.**

- Never attempt to work with the machine unless you have become fully familiar with the way it works. Should you have any doubts even after you have carefully and completely read this manual, please contact N.KO.
- Make sure that all technical workers that are supposed to use the machine and perform its maintenance are fully familiar with all the relevant safety recommendations.
- The machine must be transported and installed only by specialised workers and in accordance with the instructions contained in this manual.
- Prior to starting up the machine, the operating staff must make sure that all safety devices are functional, and all safety covers mounted.
- Never use the machine for another purpose than the one specified in the manual. Never process other than the defined products.
- Before you start using the machine for another purpose than the one described in this manual, please contact N.KO.
- The values of voltage used to power the machine are dangerous. Make sure that all the connections are made correctly, never perform maintenance or replace parts on the machine when the machine is connected to a power supply, and never make any turns on the electrical connections.
- Parts considered defective replace with other parts recommended by the manufacturer. Never replace parts with other than original ones.
- Never wear clothing or jewellery that might get caught in moving parts. It is advisable to wear safety clothing, shoes with non-slip soles, ear muffs and goggles.



#### **Important:**

**If any defects occur during the life of the machine that cannot be repaired according to this guide, it is advisable to contact the company N.KO to resolve the problem as soon as possible.**

## 2.2 Safety stickers

Safety stickers are glued on the edge chamfering machine to protect the operating staff. Meaning of stickers:

This sticker sticks to the electrical panel of the edge bevelling machine and indicates the presence of high voltage.



**Do not remove this sticker from the machine**

## 2.3 Qualification and protection of operating staff

Employer is obliged to inform the operating staff on safety standards and also ensure that those are respected, and make sure that the working area is large enough and well lit.

The term "operating staff" means a person who installs, operates, adjusts, performs maintenance, cleans and repairs the machine.



**Caution:**

**Before starting the work, the operating staff must be familiar with the characteristics of the machine, and must have read this entire manual.**



**Caution:**

**The operating staff shall always make sure that:**

1. That all safety covers are mounted, and that all safety devices are functional before they start up the machine.
2. Refrain from wearing clothing or jewellery that might get caught in the moving parts.
3. Wear the approved safety clothing, such as shoes with non-slip soles, ear muffs and goggles.
4. Apply safety standards, make sure that they are always observed and if in doubt, look again into this manual before making any arrangements.
5. Contact the machine supplier when any defects that cause malfunction of the machine cannot be removed when the defects relate to faulty parts or irregular operation.

## Safety equipment

The machine is equipped with safety covers to isolate zones that could be dangerous for the operating staff. These covers are bolted to the frame or screwed together with the machine structure. They can be removed using suitable wrenches.

Removing these covers may be necessary during certain maintenance operations.

### Caution:

**Removing the cover must always be carried out when the machine is at rest and the electrical supply line plug pulled out. Never use the machine without the mounted safety guards.**

The machine is equipped with an emergency mushroom button. It is red in colour and in priority to all other operations, it immediately stops the machine (position A or B Fig. 2.3.1).

This emergency button is used:

- in the case of imminent danger or mechanical accident;
- for short interventions when the machine is already at rest in order to enable maintenance

in this state Fig. 2.3.1

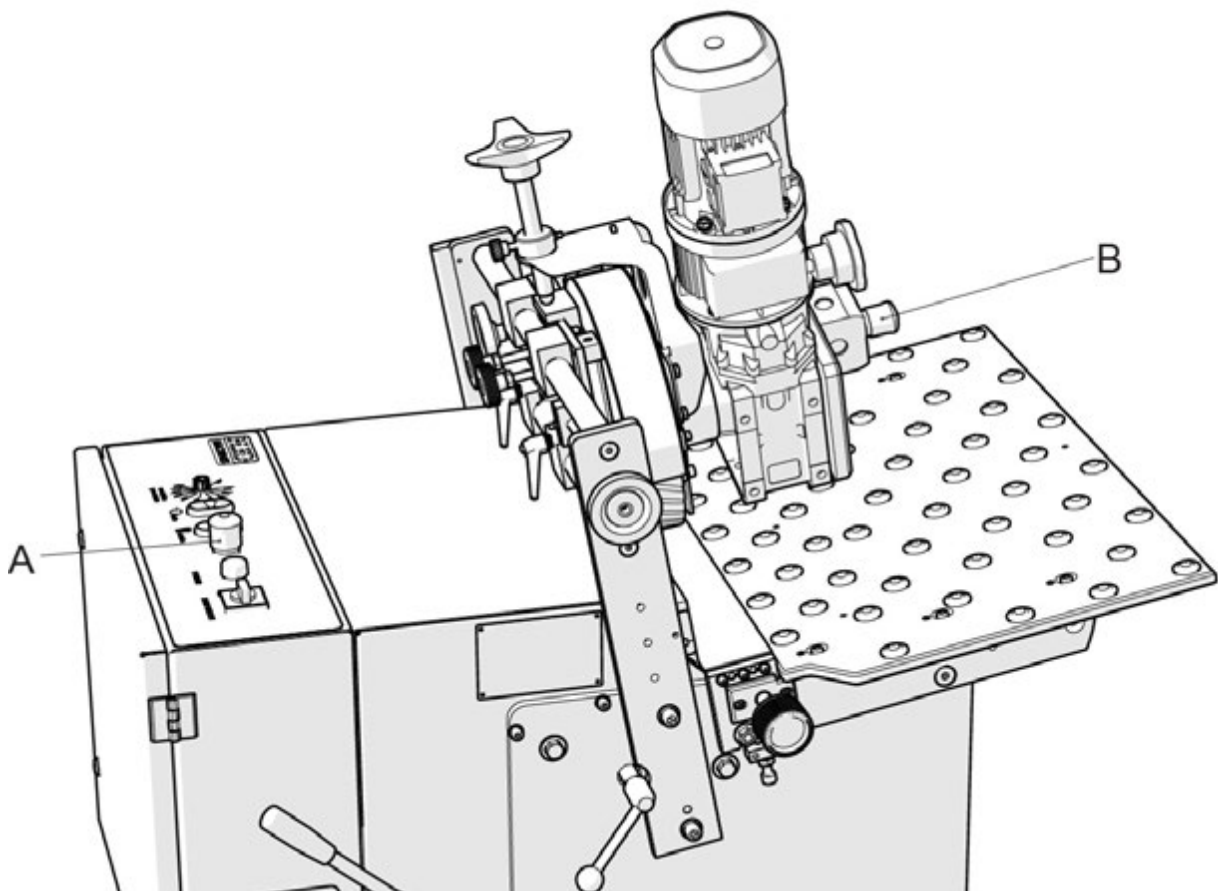

## 2.4 Residual risks

The machine was designed and constructed with all devices and equipment to ensure the health and safety of the operating staff.

The machine is fully enclosed, so that the risk of contact with the moving parts was prevented to the utmost extent.

However, there is one remaining risk:

As mentioned above, the working zone is protected as much as possible, but must remain partially open in order to insert the material for chamfering.

It is therefore possible that the operating staff may put their fingers into the zone in which both the cutting tool and the workpiece holder are located.



**Caution:**

**Keep the hands as far away as possible from the cutting zone.**



**Caution:**

**Always apply the safety procedures contained in the manual and make sure they are observed, and all remaining risks have been eliminated.**

## TECHNICAL SPECIFICATION

### 3.1 Machine description

The chamfering machine, model UZ30, is a stationary machine. One of its main features is that the angle and size of the bevel can be adjusted, and the material feed is automatic.

The machine is equipped with a milling cutter tool, robust workpiece holder, graduated scale for direct reading that is used to set values (the size of the bevel, the angle of machining), and a special guide that facilitates loading of the material.

These characteristics allow for easy adjustment of the working angle without replacing any component, and precise regulation of the size of the bevel.

The UZ30 chamfering machine is reliable and requires only minimal maintenance.

### 3.2 Technical specifications

<b>Bevel angle</b>	Infinitely adjustable within the range from 30° to 60°
<b>Bevel width*</b>	0 to 30 mm < 400N/mm <sup>2</sup> - 0 to 15 mm > 400N/mm <sup>2</sup>
<b>Cutter motor:</b>	4 kW
<b>Speed</b>	0 - 5500 rpm
<b>Tool diameter</b>	Ø 94mm
<b>Number of indexable inserts</b>	5 pieces
<b>Feed motor</b>	0.45 kW
<b>Feed speed</b>	0.6– 3.5 m/min
<b>Material thickness**</b>	2-100 mm
<b>Minimum workpiece dimensions***</b>	L = 60mm, W = 20mm
<b>Weight</b>	400 kg
<b>Working height</b>	1,000 mm
<b>Pipe treatment</b>	Ø 102 – 156 mm
<b>Machine dimensions</b>	See figure 3.2.1.

\*Accurate information to be found in the able in chapter 5.3.

\*\*It is always necessary to choose the appropriate ratio of length and cross section of the workpiece in terms of the total weight of the machined piece. Otherwise there is a risk of an overload of the feed mechanism.

If the feed mechanism is unable to smoothly move the workpiece to the cut, it is forbidden to continue in the operation, or move the workpiece manually.

\*\*\*The minimum and maximum dimension of the workpiece is always subject to the test. The presented data are the results of tests under ideal conditions. If a problem occurs with the fluidity of the material feed, or the material jams in the guide mechanism, immediately stop work.

Fig. 3.2.1.

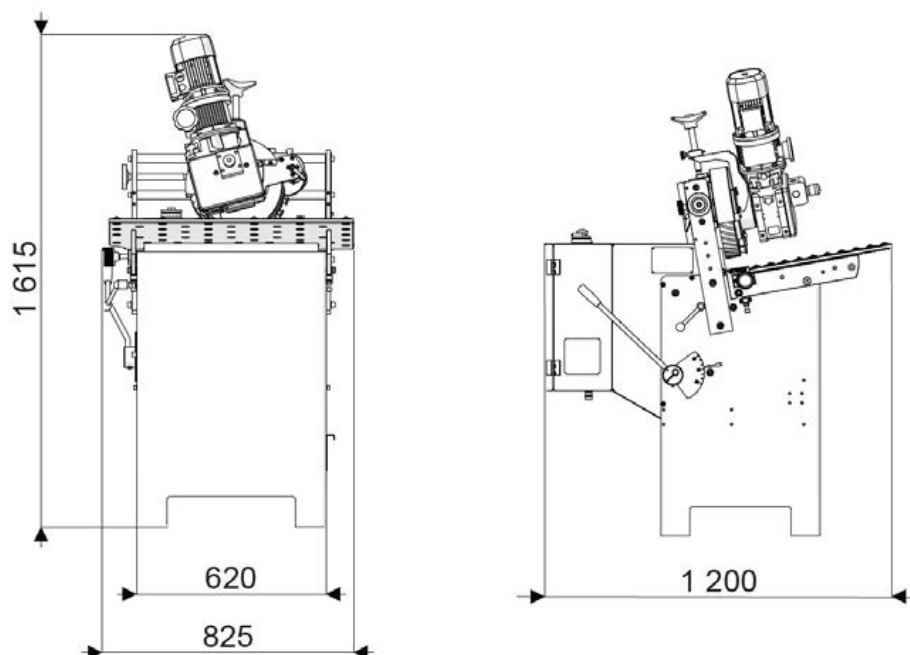

### **3.3 Noise level**

The machine was designed and manufactured so that the noise that it emits is minimized. .

The continuous acoustic noise level, as measured by A in some cases and under certain operating conditions, exceeded 85 dBA. Workers must use ear defenders.

### **3.4 Conditions of work environment**

The environment in which the machine operates must comply

with the following values: Temperature: 0° C - 50° C

Humidity: 10% - 90% (uncondensed)

The machine must be placed under cover and not be exposed to rain.

Any conditions of the working environment other than the above may cause serious damage to the machine, especially electrical equipment.

If the machine does not work, it may be stored in a dry place where the temperature fluctuates between -10°C and 70°C. All other values remain unchanged.

## **INSTALLATION**

### **4.1 Transport and lifting**

#### **Important:**

**The operations described in this section shall be performed by qualified personnel only.**

Suitable unloading and establishing means (cranes, forklifts etc.) must be available at the destination.

When the machine is delivered to the place of destination, make sure (yet in the presence of the carrier) that it meets the specifications in the order and that it suffered no damage the during transport. Inform N.KO and the carrier in detail immediately should any damage or missing parts be detected.



**Caution:**

**Please observe the following instructions and ensure that handling the machine is safe:**

- Keep safe distance from hanging burdens and make sure that the lifting equipment and related handling equipment and tools are in perfect order and are suitable for the dimensions and weights listed in paragraph 3.2.
- Wear protective equipment, such as. work gloves, shoes with non-slip soles and a helmet during handling the machine.
- If the machine is in a carrying case, remove it and dispose of it in accordance with the applicable laws of the country.

## 4.2 Installation and connection

**Important:**

**The operations described in this section shall be performed by qualified personnel only.**

The machine must be set up on a flat surface. We recommend that the machine is fixed to the floor by means of anchors through corresponding holes in the legs of the machine (Fig. 4.2.1.), especially if you intend to use the additional tables with the machine (see accessories).

Fig. 4.2.1.

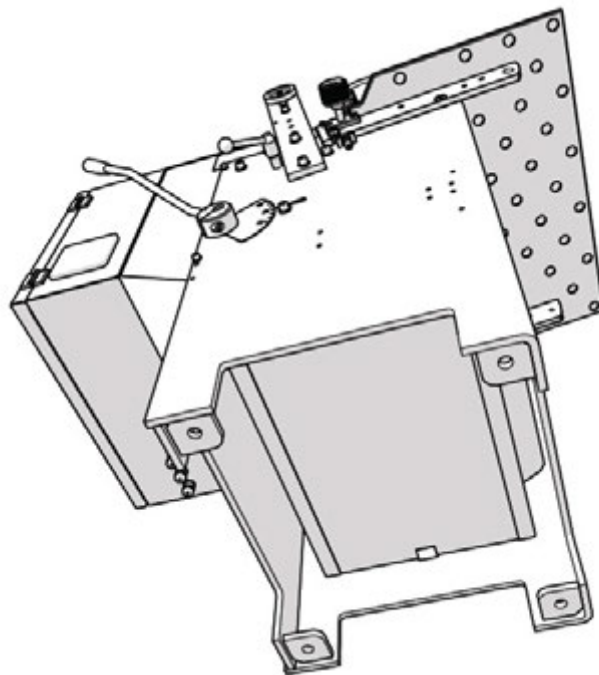

The machine comes with an open working table (Fig 4.2.2.). It has to be folded into working position before starting the machine. Follow these steps:

- Unfold the feed drive upward and to the right (position A Fig. 4.2.2.).
- Tilt the working table (position B Fig. 4.2.2.) to working position and tighten the nuts securing the working table (position C Fig. 4.2.2.).
- Cover up the feed drive (position A Fig. 4.2.2.). **CAUTION!** It is necessary to unlock the drive tilt (position H Fig. 5.2.1).

Fig. 4.2.2.

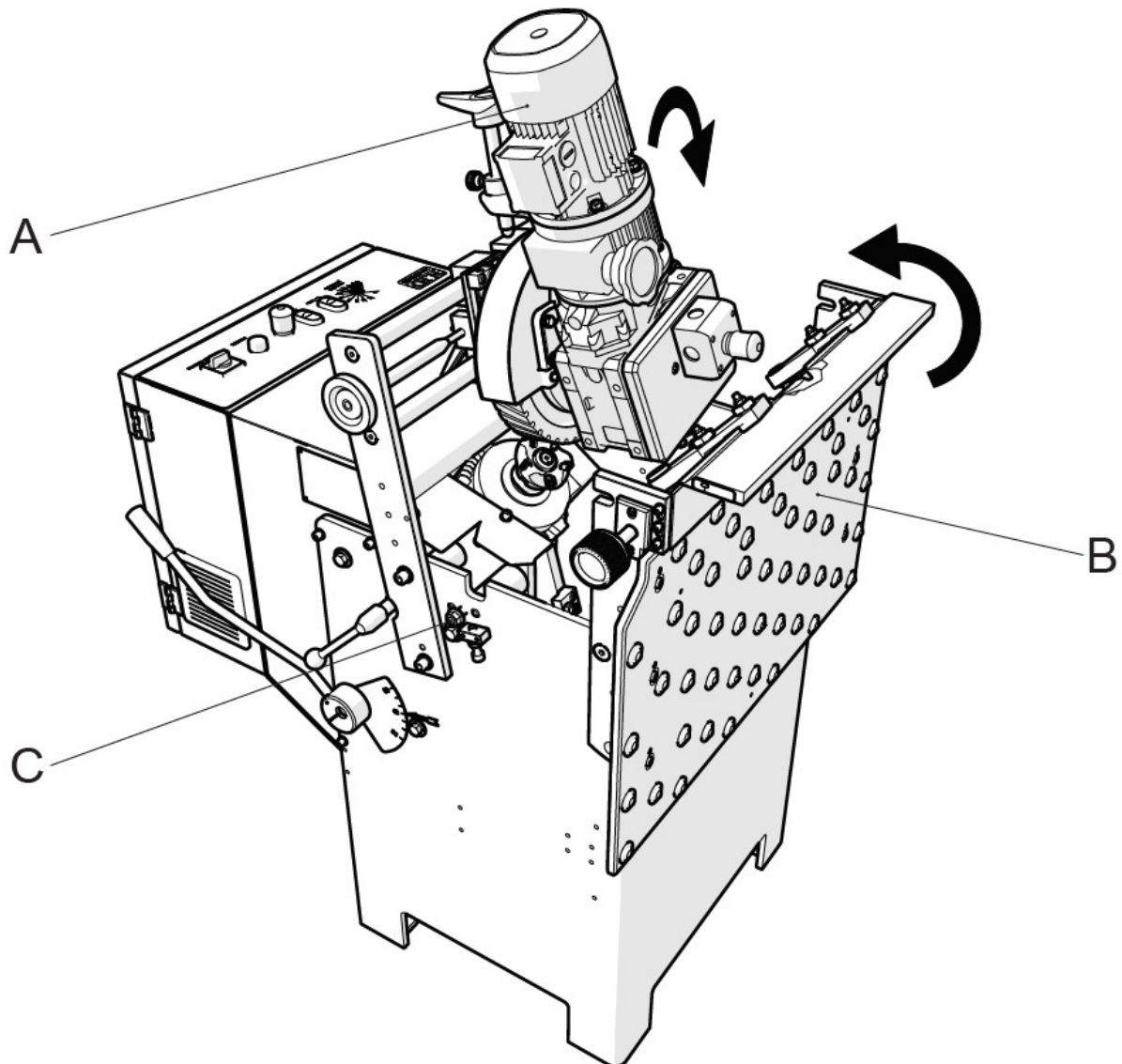

When doing the wiring, follow these steps:

- check the frequency and voltage values on the identification plate of the engine;
- connect the plug end of the cable to the power line accordingly with your local electricity distribution.

### 4.3 Checks before commissioning

#### Important:

**Never run UZ30 without performing the checks described in this paragraph.**

Before starting the machine make sure that the machine is ready for operation by the following controls and inspections, in order to achieve the highest possible efficiency, and meet the safety procedures:

- **make sure that no screws or other parts are loose;**
- make sure that all electrical connections have been made correctly, and that the power cable is held in place with cable gland;
- make sure that the cutter does not collide with another part of the machine, and can rotate freely.
- To start the machine, proceed as follows:  
Release the machine with the red emergency button (positions A and B Fig. 2.3.1.). Turn on the power supply switch (position E Fig.5.2.1.) Start the engine with the green button (position B Fig. 5.2.1.)  
The cutter must rotate clockwise. If not, you need to throw the phases in the plug.
- To turn the machine off, use the red button located next to the startup selector switch (positions B Fig.5.2.1.)

### 4.4 Destruction and disposal

When destroying the UZ30 machine, keep in mind that the materials it is made of are not of dangerous nature, and that they include mainly:

- lacquered or metallised ferritic steel;
- series 300/400 stainless steel;
- plastic material of different nature;
- gear oil;
- electromotor;
- electric cables and the corresponding shells;
- electrical monitoring and excitation

equipment. Follow this procedure:

- follow the applicable laws of the country relating to the safety of the working environment;
- unplug the machine from the electrical supply;
- demount machine components and sort into groups according to their chemical nature;
- scrap machine parts in accordance with the applicable laws of the country;
- during the disassembly stages, observe strictly the applicable work safety regulations.

## USE

### 5.1. Proper use

The UZ30 model machine for bevel chamfering was designed, manufactured and sold for chamfering of metal components and rolled metals of the following types: **iron, steel, stainless steel**, brass, copper, aluminium and some plastics.

UZ30 is developed especially for bevelling of larger series of smaller format workpieces or long flat and square bars. It is also possible to bevel tubes, as advised in the Accessories chapter.

The design of the machine allows very efficient bevelling in a single setup and big series.

The thickness of the machined material and other technical information are detailed in Chapter 3, Section 3.2 "Technical specifications", and in paragraph 5.3 "Preliminary settings".

 **It is always necessary to choose the appropriate ratio of length and cross section of the workpiece in terms of the total weight of the machined piece. Otherwise there is a risk of an overload of the feed mechanism.**

Other uses differing from the above described are considered improper. Specifically, it is forbidden:

- process any products differing from those that the machine is manufactured and sold for;
- modify the construction of the machine;
- replace parts with other than original;
- modify the electrical connections, thus bypassing the internal security devices;
- remove or modify protective guards;
- use the machine in places with aggressive atmosphere.

 **Caution:**

**It is strictly forbidden to perform bevel chamfering on materials differing from the listed ones, because their processing could become a risk for the operating staff, and may damage the machine.**

The company N.KO must be notified before making any modifications, to issue an adequate approval. Otherwise the company disclaims any liability.

### 5.2. Description of controls

The bevel chamfering machine is controlled using the controls located on the machine and the control cabinet.

Fig.5.2.1. Machine

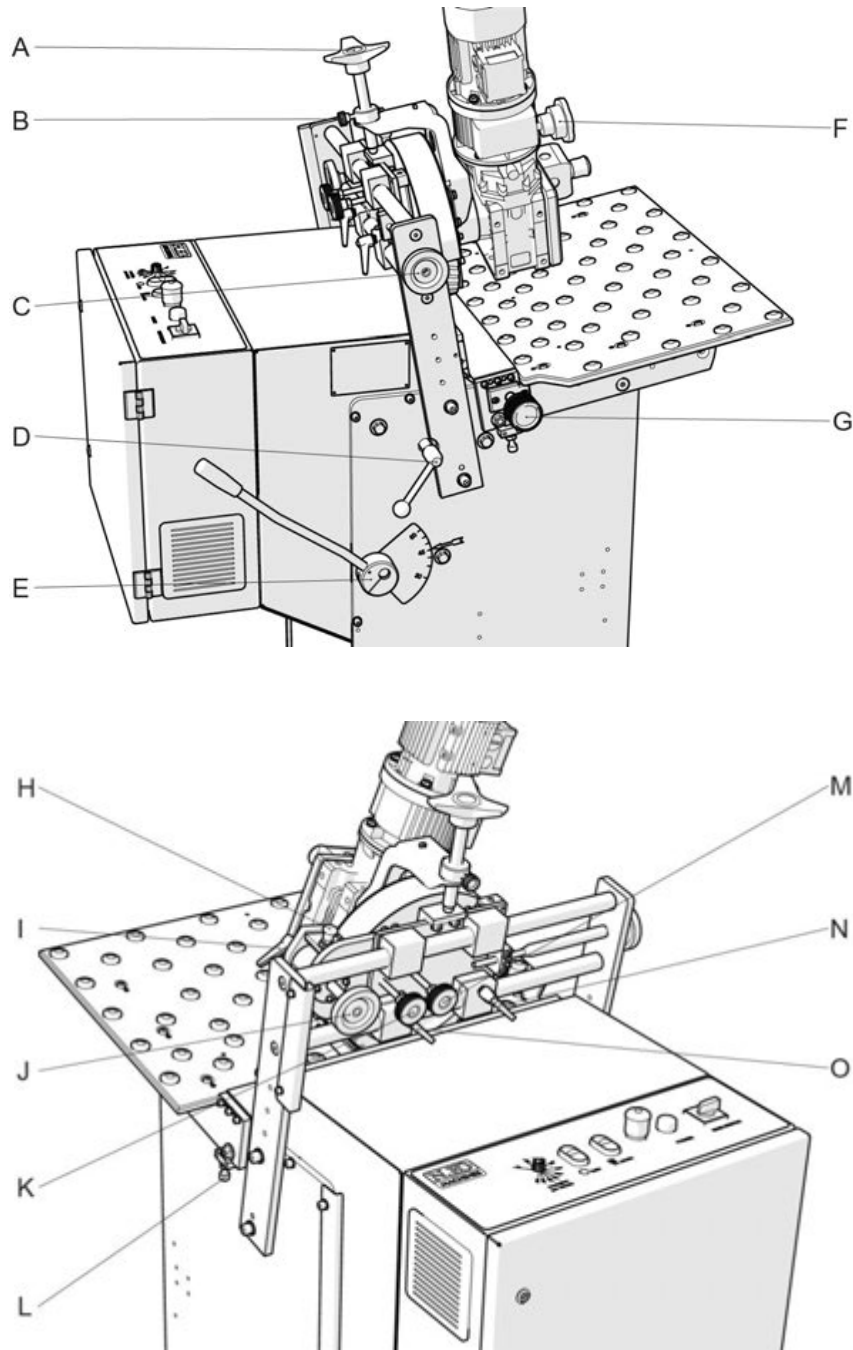

- A** Setting the height of the feed wheel
- B** Feed wheel height adjustment lock
- C** Setting the right / left position of the feed wheel
- D** Bevel angle adjustment lock
- E** Bevel angle adjustment lever
- F** Feed speed adjustment
- G** Reduction size adjustment
- H** Feed arm lock in unfold position
- I** Feed wheel unloading lock
- J** Feed wheel unloading adjustment
- K** Feed wheel I inclination adjustment
- L** Setting the height of the working table
- M** Feed wheel I inclination adjustment
- N** Lock of the right / left position of the feed wheel I
- O** Lock of the right / left position of the feed wheel II

Fig.5.2.2. **Distribution box**

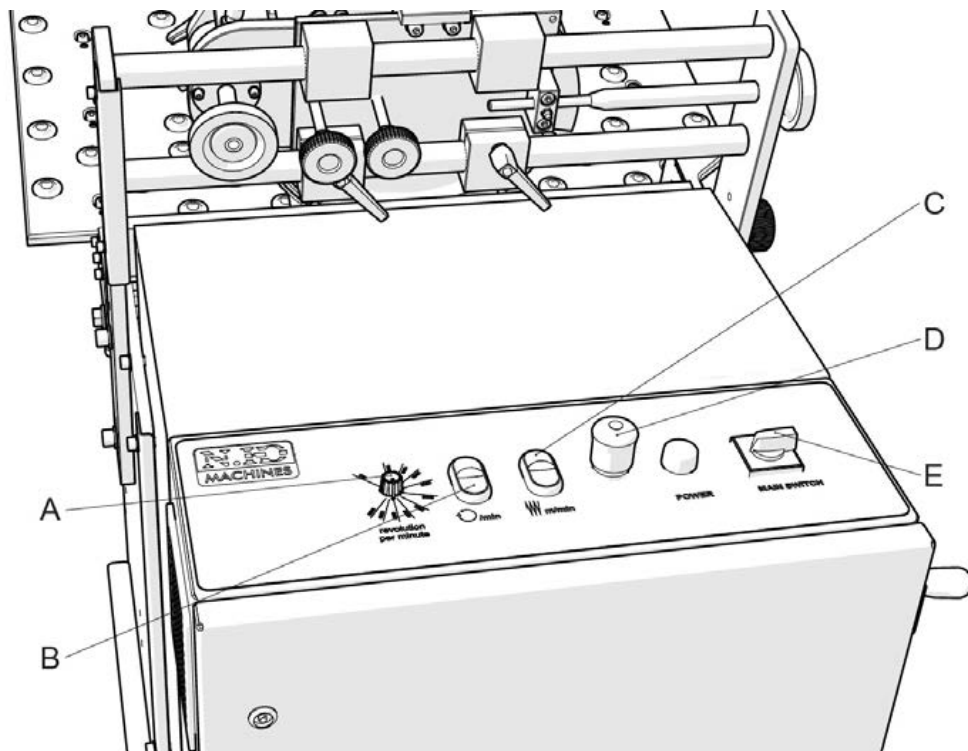

- A** Cutter spindle speed control
- B** Cutter drive start / stop button
- C** Feed mechanism start / stop button
- D** Emergency stop button
- E** Main switch

### 5.3. Presetting

#### **Caution:**

**During the adjustment operation wear gloves. The operations must be carried out on the machine at rest and after disconnecting from the power supply.**

Before starting work, you will need to perform some of the following settings:

#### **Bevel angle adjustment**

The bevel angle can be varied continuously from 30° to 60°.

When adjusting, proceed as follows:

- Release sufficiently the angle setting lock (position D Fig. 5.2.1) located on the side of the machine.
- Grab the adjustment lever (position E Fig. 5.2.1) and pulling it, adjust the required angle.
- The set angle value can be read on a divided scale which is part of the adjustment lever.
- Once the operation is completed, retighten the angle setting lock (position D Fig. 5.2.1) located on the side of the machine.

### Setting the inclination and the right / left position of the feed wheel

By adjusting the inclination of the feed wheel we can change the angle of the feed path relative to the vertical guide plate. In other words, we are able to affect the ability of the machine - to maintain the worked material in contact with the guide plates.

The UZ30 machine is equipped with a system that allows the adjustment of the settings according to the currently processed material and the cutting conditions.

When adjusting, proceed as follows:

**For value X (X value is recommended to be set to 11.5 mm)**

- Loosen or tighten screws (position K and M Fig. 5.2.1) against each other until you achieve the required inclination.
- The screws must be eventually tightened against each other - counter.

**For value Y (Y value is recommended to be set to 205mm)**

- Enable the levers (position N and O Fig. 5.2.1)
- using the rotary control (position C Fig. 5.2.1) to adjust the required position of the feed wheel
- Tighten the levers (position N and O Fig. 5.2.1)
- 

**Based on our experience, we recommend that the recommended setting values of the inclination and of the right / left position of the feed wheel are observed, as indicated in figure 5.3.1.**

**The machine is pre-adjusted according to the above.**

Fig.5.3.1.

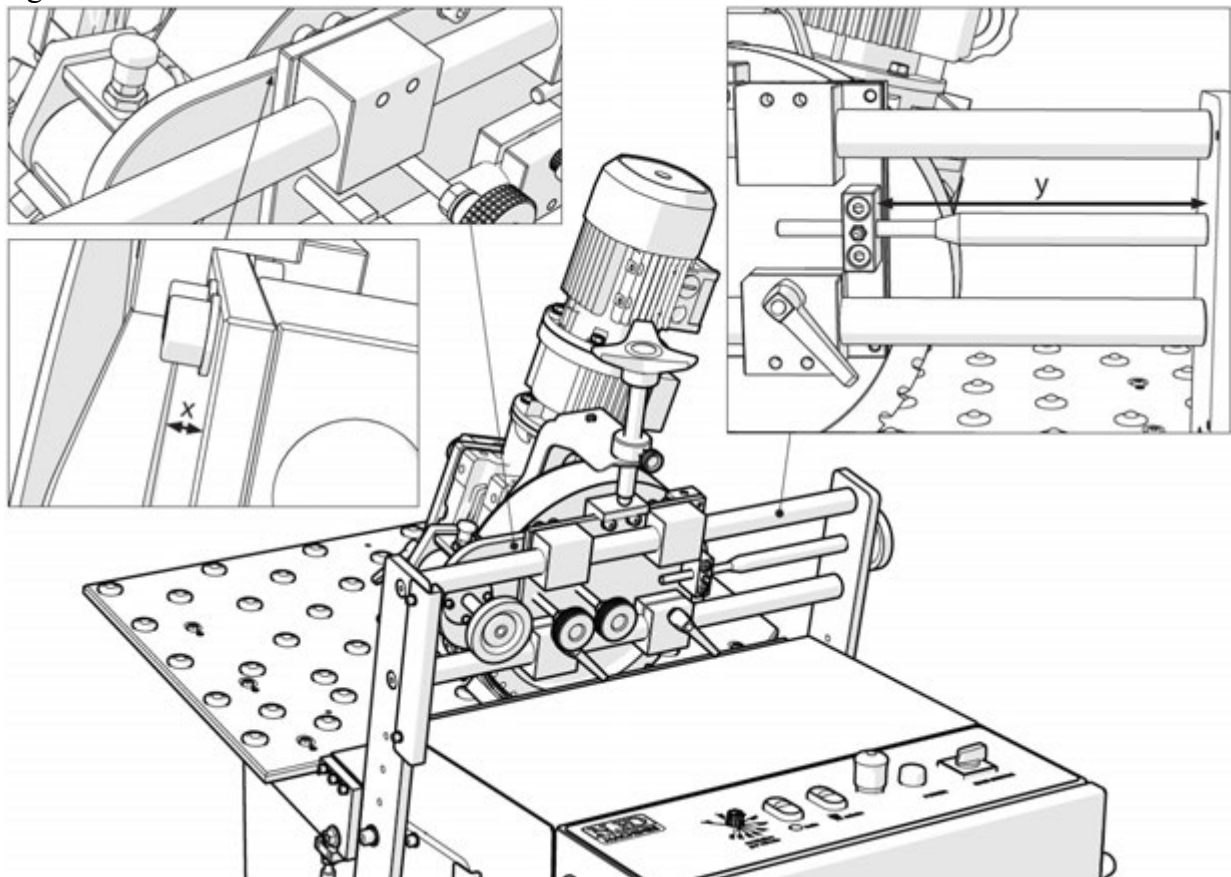



**Caution:**

During the adjustment operation, wear gloves. The operations must be carried out on the machine at rest and after disconnecting from the power supply.

**Setting the unloading of the feed wheel**

By adjusting the unloading of the feed wheel we can change the angle of the feed wheel relative to the vertical guide plate. The option of unloading readjustment is particularly useful during bevelling of L profiles when it is necessary to adjust the unloading of the feed wheel according to the L profile flange wall thickness (Fig.5.3.2.).

When bevelling flat material, on the contrary, we recommend that the unloading is adjusted so that the feed wheel was as close as possible to the vertical guide plate.

Fig.5.3.2.

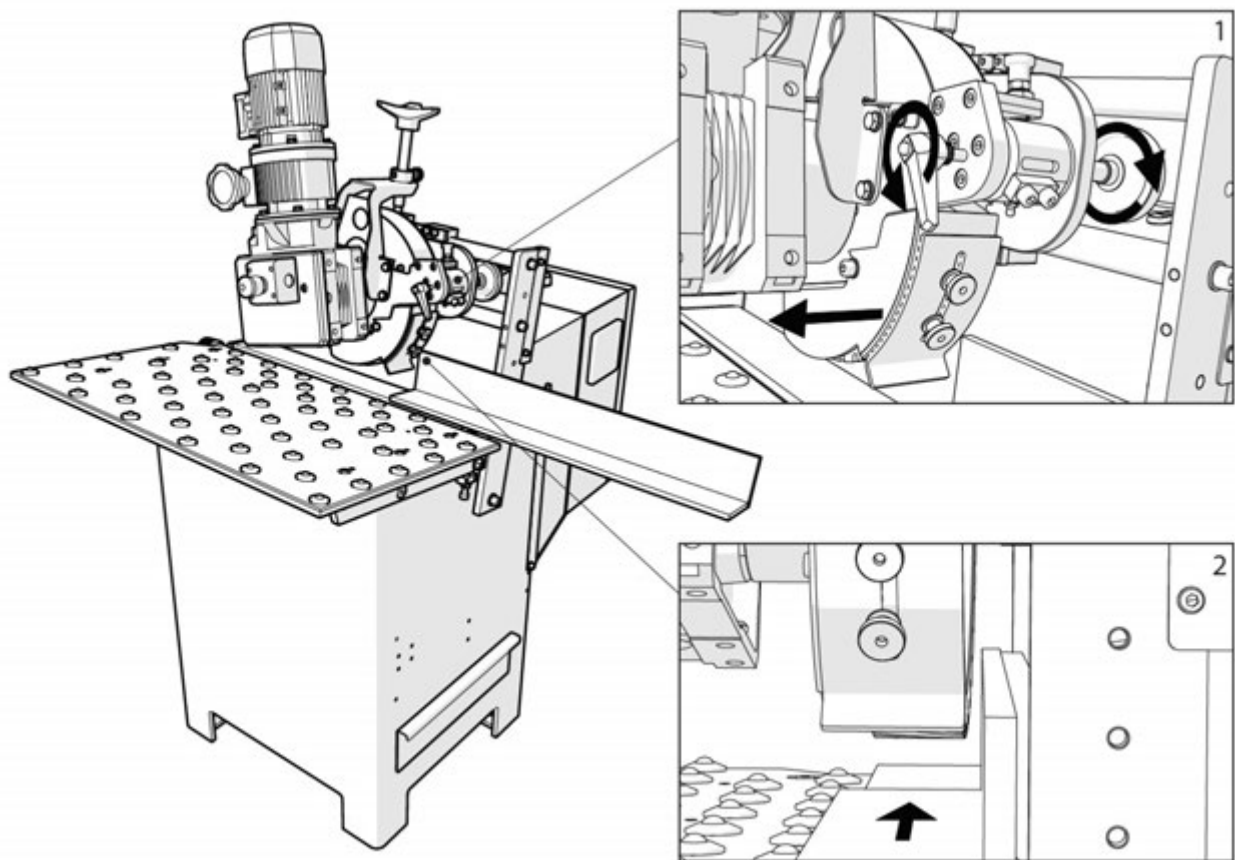

When adjusting, proceed as follows:

- Enable the feed wheel unloading lock (position I Fig. 5.2.1)
- Using the unloaded feed wheel adjustment control (position J Fig. 5.2.1) adjust the unloading of the feed wheel as needed
- Retighten the feed wheel unloading lock (position I Fig. 5.2. 1)

## Setting the height of the feed wheel

Before starting work, it is necessary to adjust the height of the feed wheel. The optimal height adjustment of the feed wheel above the horizontal guide plate is by about 5mm less than the actual thickness of the workpiece. It means that when machining a 40 mm thick material set the wheel height 35 mm above the horizontal guide plate.

When adjusting, proceed as follows:

- Enable the adjustment lock (position B Fig. 5.2.1.)
- Set the right height of the feed wheel by turning the adjustment wheel (position A Fig. C.5.2.1.)
- Tighten the adjustment lock (position B Fig. 5.2.1.)

## Setting the reduction size (GAUGE) and cutting conditions

The maximum reduction capacity of the machine in different angles is shown in the table below the text. These maximum values can only be achieved by gradual multiple-step machining. To ensure correct adjustments for each reduction, use the gauges supplied with the machine. 5.3.3. a 5.3.5.).

Machining angle $\alpha$	Bevel height (A)	Bevel width P	Recommended number of reductions
30°	26mm	30mm	3
35°	20.4mm	25mm	3
37,5°	18mm	22.5mm	3
40°	16.5mm	21.5mm	3
45°	14mm	20mm	3
50°	11.7mm	18mm	3
55°	10mm	17,5mm	3
60°	8.5mm	17mm	3

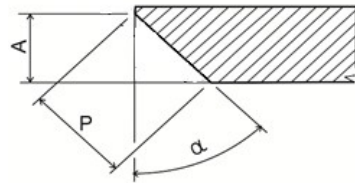

Applies to material of strength up to Rm max 60kg/mm<sup>2</sup>

Fig. 5.3.3.

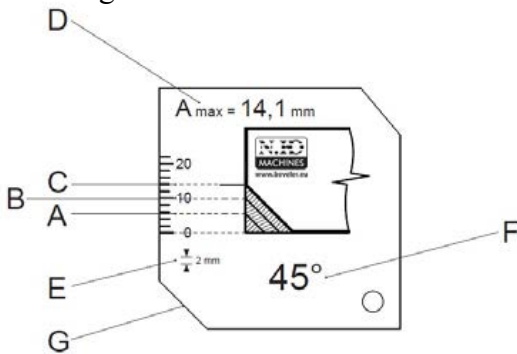

- A Maximum reduction for the first splinter on the bevel height scale A
- B Maximum reduction for the second splinter on the bevel height scale A
- C Maximum reduction for the third splinter on the bevel height scale A
- D Total maximum possible height of the bevel for a particular angle (in this case 45°)
- E Size of deduction scale division = 2 mm
- F Gauge for bevel angle  $\alpha$  45° (available are gauges 30°/35°/37.5°/40°/45°/50°/55°/60°)
- G Sample of maximum removal (reduction) (in this case 45°)

On the gauges, you can deduct the actual set bevel size, the size of the next set removal, of the maximum material removal in one splinter, and the recommended number of splinters to achieve the maximum total removal (see Figure 5.3.3.).

Attach the gauge to the vertical and horizontal guide bar at the point where the reading scale is fastened on the side (see Fig. 5.3.4.).

The gauge must be properly attached and in full contact with the guide

rails.

Fig. 5.3.4.

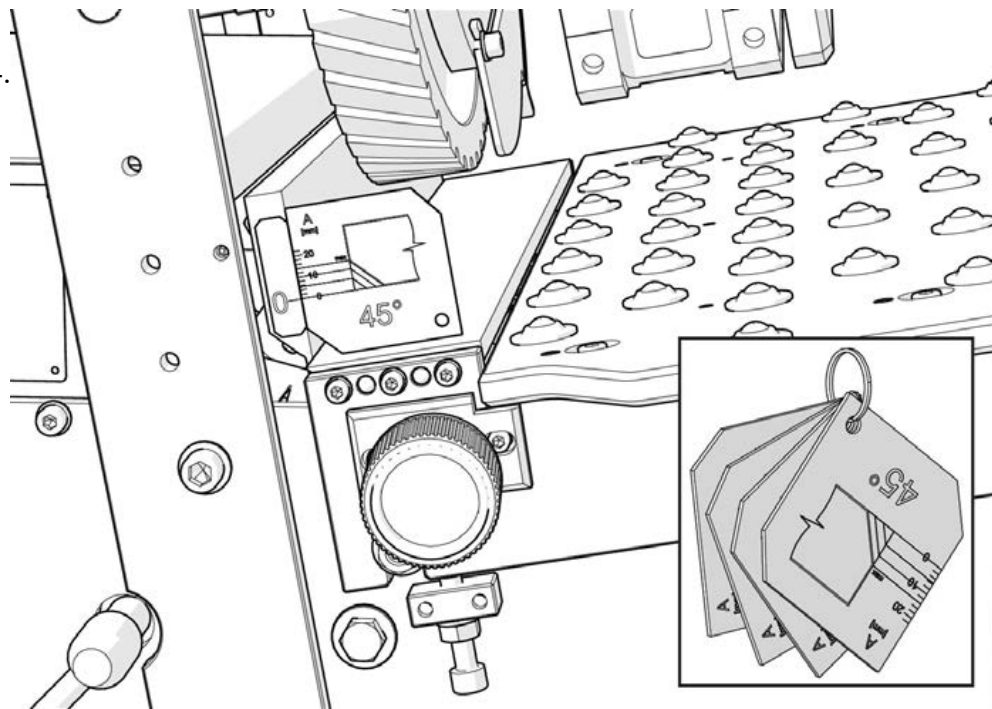
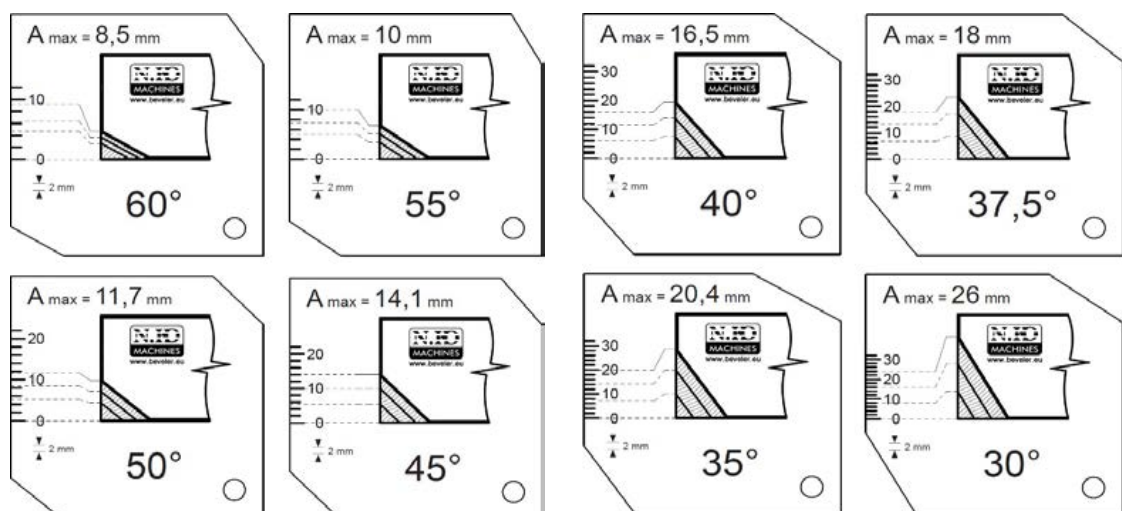

Fig. 5.3.5.





### **Important:**

The basic height of the working table is set at the factory. It is sealed and secured by an adjusting screw against readjustment (position C Fig. 5.3.6.). If you do decide to readjust the height of the table, keep in mind that the size of the subsequently executed bevel will not correspond with the value on the gauges.

To re-calibrate the height, proceed by the chapter 6.3. - "Calibration of the table height."

Fig. 5.3.6.

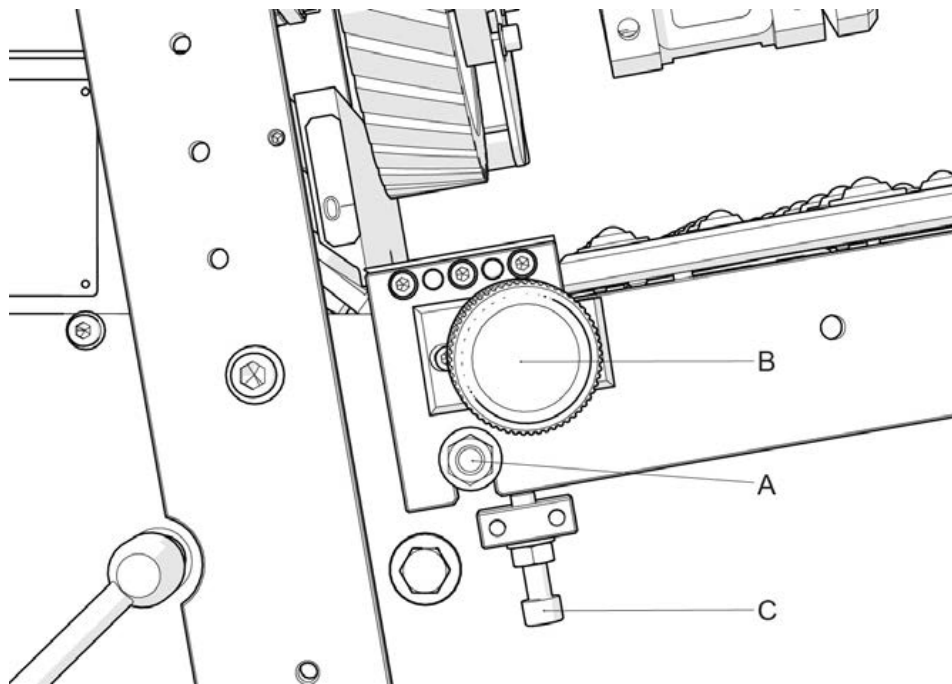

### **Cutter speed setting**

The machine UZ30 cutter speed range is 0 to 5500 rpm.

The special design of the cutting tool with unique indexable inserts allows high-speed machining.

For structural steel, we recommend a maximum speed of 5000 - 5500 rpm. Set the speed by a rotary switch (position A Fig. 5.2.2.). We always recommend that you perform a test. If you find that for a given material other than the recommended revolutions are preferable - adjust it according to your experience.

### **Feed speed adjustment**

The UZ30 machine is equipped with variable feed. The speed can be set from 0.6 to 3.5 m/min. We recommend that you perform a test on a material sample, and determine the most suitable feed rate. The optimal speed is affected by many factors, such as the condition of the indexable inserts, the size of the removal, or the quality of the removed material.

You can set the rate by turning the control knob (position F Fig. 5.2.1.)

### **Important:**

The feed rate adjustment operation can only be performed when the feed wheel is in run. In the event that you turn the control knob when the feed is off, there is a risk of destroying the variator.

### **Setting up the first removal**

Set the first removal as needed by the rotary sliver setting knob (position G Fig. 5.2.1). Each individual removal must not exceed the maximum limit for a single sliver, as advised in chapter - **Adjusting the size of removal and machining (GAUGES)**.

 **Important:** The maximum depth of individual removal is determined by the adjustment gauge. Follow the recommended values on the adjustment gauge. If you set more to one removal, there is a risk of imminent destruction of the tool.

 **Important:** The UZ30 machine has been designed especially for the execution of large series of workpieces. Professional machine adjustment for a specific long-term work is assumed. For this reason, it is not possible to recommend one universal setting of the feeding device and the entire machine.

There are factors, such as the roughness of the workpiece surface - the friction, the weight, the dimensions and the shape of the workpiece, the condition of the cutting tool, that affect the ideal setting of the workpiece. We recommend that Teflon spray is applied on the guide plate to reduce friction.

## **5.4. Machining**

- Prepare bevelled sheet or profile on the right side of the table. The machining direction is from the right to the left.
- Turn on the cutter (position keys B Fig. 5.2.2) and feed motor (position C Fig. 5.2.2) and set a suitable speed rate (position A Fig. 5.2.2) of the cutter and the rate of the feed (position F Fig. 5.2. 1) according to the material quality, the condition of the indexable inserts and the size of the set removal.
- By gradual pressure, guide the workpiece under the feed wheel. If the machine is properly set the feed wheel grasps the material and draw it into the machine. The workpiece must be held in proper position (in contact with the guide rail) for the first roughly 50 mm. The beginning of the workpiece must get behind the milling box located in the vertical guide.

### **Important:**

During the bevelling, the conditions may change and a situation may occur when the machine settings may need to be changed.



**Caution:**

**The vertical guide rail must under any circumstances provide the machined material with support, preventing the penetration of the material into the cutter zone. Test proper setting prior to the commencement of works.**

## Setting another removal

The UZ30 machine is capable, in certain angles, to create a chamfer width up to 30 mm (see the chapter **Adjusting the size of removal and machining GAUGES**).

These values can only be achieved by gradual multiple-removal machining.

If the ultimate size of the bevel requires, it is necessary to set another following removal after the first one.

Use the rotary control knob of sliver setting (position G Fig. 5.2.1) to set another removal as needed.

No individual removal may exceed the maximum limit for a single sliver, as advised in chapter - **Adjusting the size of removal and machining (GAUGES)**.



**Important: The maximum depth of individual removal is determined by the adjustment gauge. Follow the recommended values on the adjustment gauge. If you set more to one removal, there is a risk of imminent destruction of the tool.**

- Start machining. Proceed in the same manner as during the machining of the first removal.
- All other removals are repeating the one stated above in chapter 5.4.



**Caution:**

**In the second and following removal, the material has to be loaded in the machine by the right side. It means the side where the removal has already been created.**

## Maintenance and adjustment

### 6.1 Recommendation



**Important:**

**Maintenance workers must be qualified technicians.**

Never perform any maintenance operation on the moving parts of the machine, not even using tools or other objects. For adjustment and maintenance operations use the tools supplied with the machine.

It is strictly forbidden to remove the safety equipment, modify it, or handle the safety covers on the machine. If such conduct occurs, the manufacturer denies any liability for safety.

Always use original spare parts (see chapter 8.3 "Spare parts list")



**Caution:**

**Always wear gloves when performing maintenance on the machine. Only perform maintenance operations when the machine is off at rest and after disconnecting the electricity.**

Before each work shift and then as needed during the shift clean machine, the tool, and the moving parts with compressed air.



**Caution:**

**When using compressed air for cleaning, wear safety goggles and never use a pressure exceeding 2 bar.**

Check the amount of waste in the sliver box (position A Fig. No. 6.1.1.). If the box is full, it is necessary to empty the waste into designated containers.

Fig. 6.1.1.

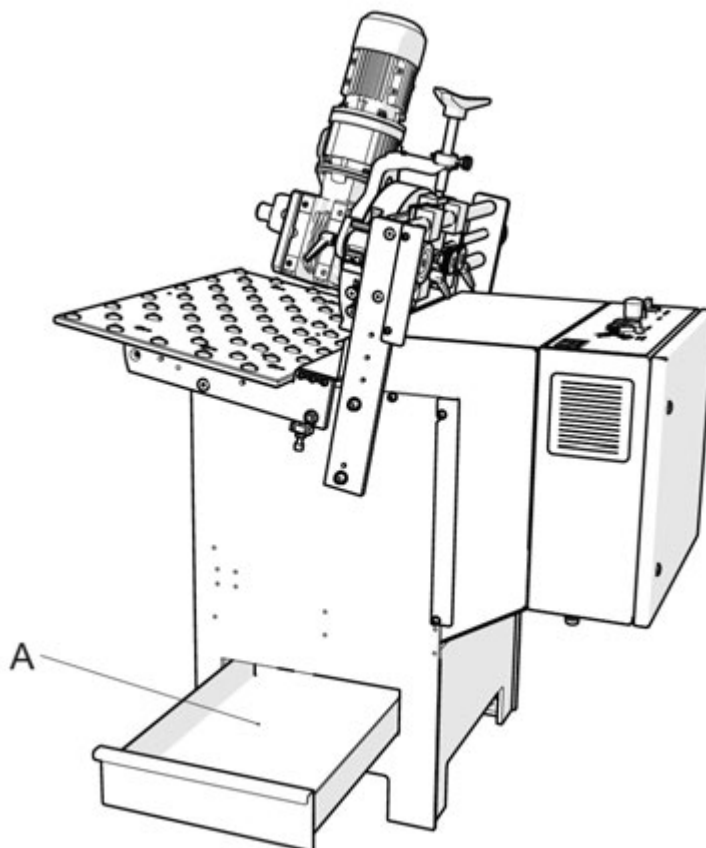

## 6.2 Demounting the cutter and replacement of indexable cutting inserts



**Caution:**

**When replacing the tools wear work gloves.**

UZ30 uses a face mill of own design for machining with indexable inserts of four cutting sides. To make full use of the indexable inserts, these inserts must be turned after blunting. In total there are 4 cutting sides on each insert.

The condition of the inserts must be regularly checked and, if worn, turned in a timely manner.

### Dismantling the milling head:

To be able to dismantle the cutting tool, the working table must be folded first (Fig 4.2.2.).

Follow these steps:

- Unfold the feed drive upward and to the right (position A Fig. 4.2.2.).
- Loosen the nuts (position C Fig. 4.2.2.)
- Unfold the working table (position B Fig. 4.2.2.)
- Secure the spindle against turning. Use the attached special spanner (position A Fig. 6.2.1).
- Use the attached Allen wrench to loosen the main centre screw that holds the cutter head on the spindle (position B Fig. 6.2.1)
- Remove the screw including the central insert and pull the cutter head down by hand from the spindle.

Fig. 6.2.1.

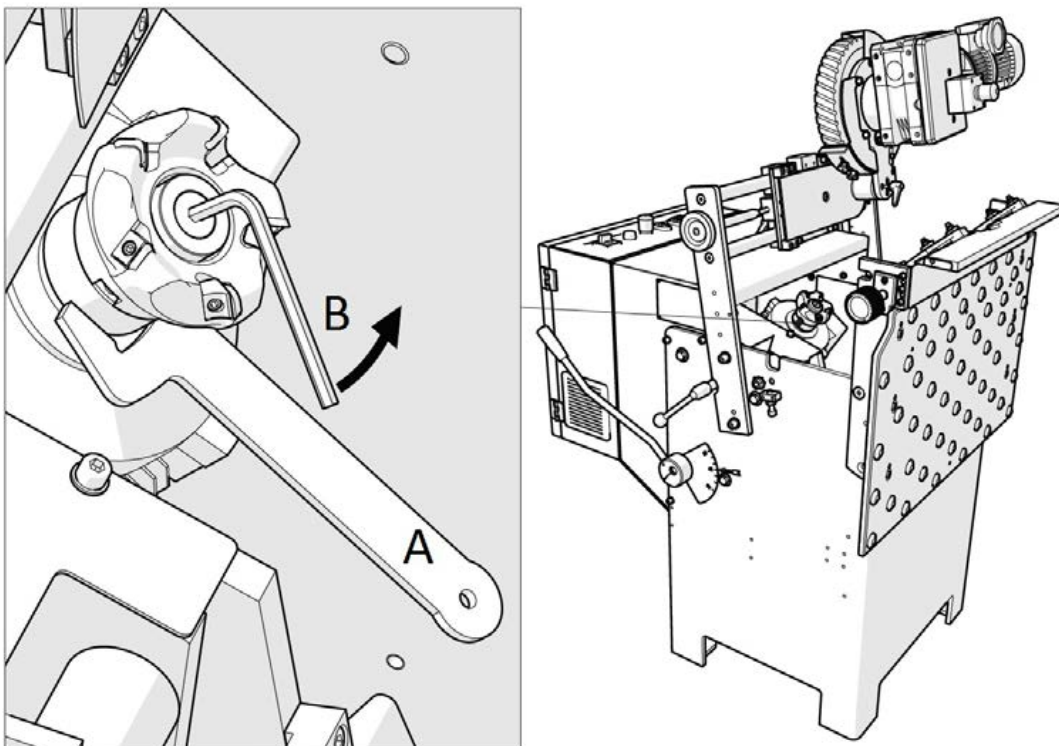

### Exchange or turning of indexable cutting inserts:

- Place the cutter head on a suitable mat.
- Use the attached Allen wrench to loosen the locking screw, loosen the indexable insert wedge (Fig. 6.2.2.) and turn or replace the indexable insert. The UZ30 machine cutter is fitted with five inserts.
- Refit the cutter.

Fig.6.2.2.

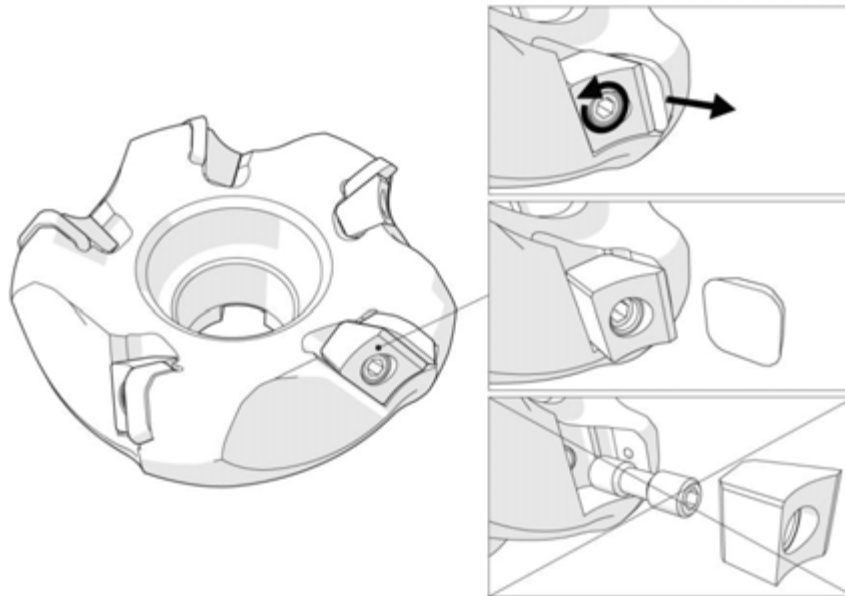

### ■ Important:

Unique indexable insert is provided with a relief that engages a projection in the housing of the indexable insert on a tool body (Fig. 6.2.3).

This relief serves as a safety device against release of the insert from the proper position in high-speed machining. Ensure proper seating of the indexable insert!

Fig. 6.2.3.

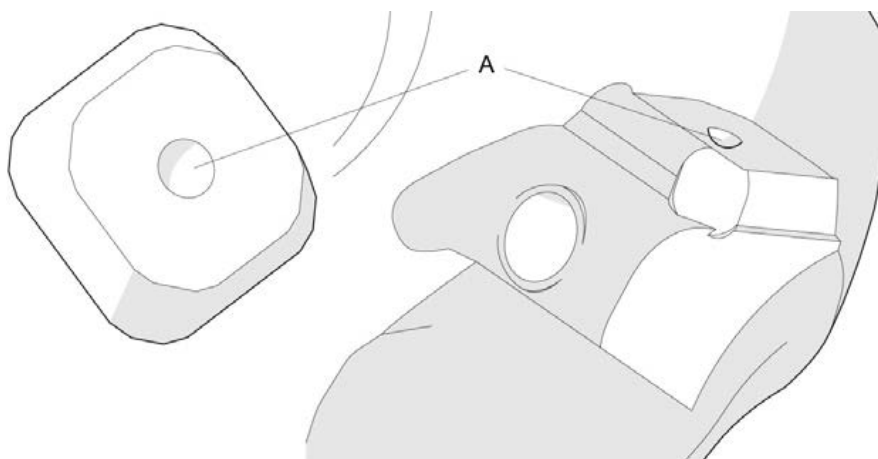

**Important: Keep all parts of the milling head (inserts, screws, cutter bolt, centre insert) and the spindle clean. Otherwise there is a risk of poor fit of the indexable inserts and their shorter life. Furthermore, there is a risk of possible jamming of the milling head on the spindle and consequent difficulty in the next disassembly.**

### 6.3 Lubrication

Periodically it is necessary to check the feed gear oil for leaks. To check it, use the inspection window on the side of the gearbox. If there is oil, everything is fine. The variator oil filling must be replaced every 300 hours of operation. The amount of oil in the gearbox is 0.7 litres.

We recommend that you use SHELL SPIRAX S4 ATF HDX. The filling hole can be found on the gearbox housing (position A Fig. 6.3.1).

The used oil drain hole is here (position B Fig. 6.3.1.)

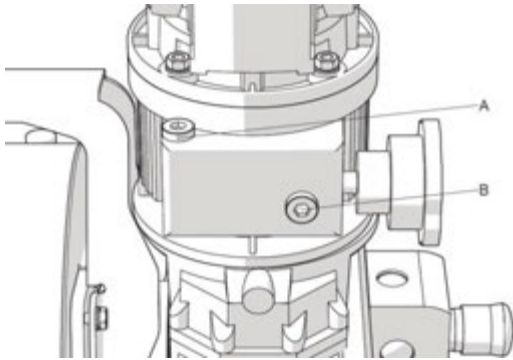
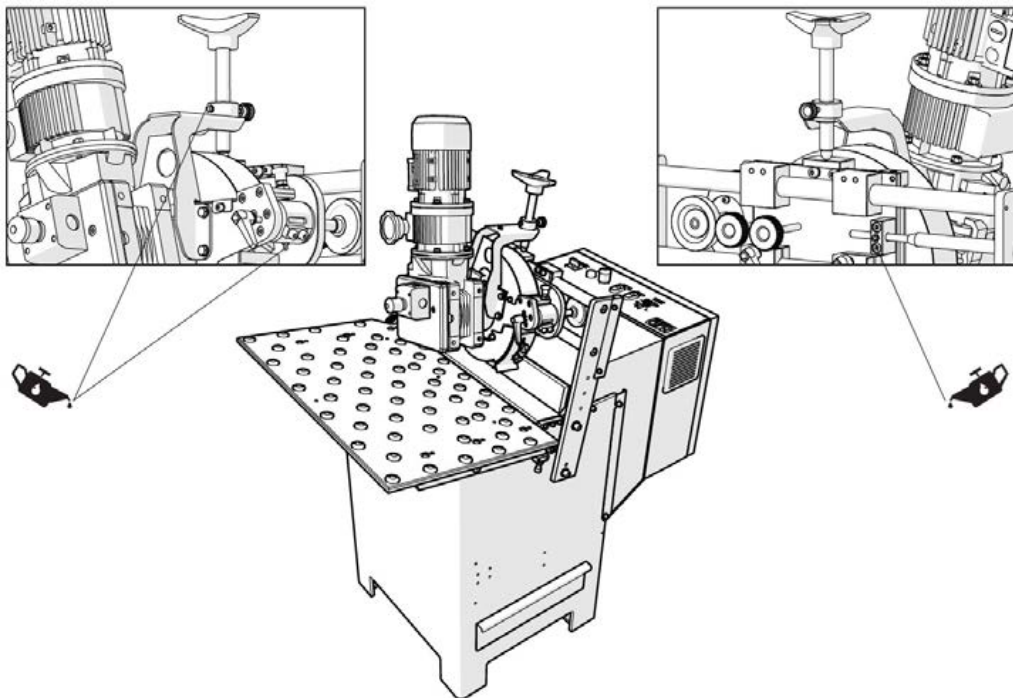

Fig.6.3.1

There are several grease nipples on the UZ30 machine (Fig. 6.3.2) that must be kept clean and filled with lubricant at least once a week. Recommended grease Shell Alvania RL 2 The recommended lubricant is Shell Alvania RL 2.

Fig.6.3.2.



## 6.4 Table height calibration

In the event that the values on the bevel height gauges are inconsistent with the actual size of the reduction, it is necessary to calibrate the height of the table.

This can occur in the event of improper use of the machine, in the case of height adjustment to increase the maximum material removal, or by simple use and loosening of the joints due to vibrations.

Calibrate the table as follows:

- Loosen the nuts securing the working table (position A Fig. 5.3.5.)
- Set the working table to the highest position by the adjusting screws (position C Fig. 5.3.5.)
- Then set the bevel angle by the adjustment lever (position E Fig. 5.2.1.) of 45° and secure the setting (position D Fig. 5.2.1.)
- Use the rotary adjustment knob of reduction size setting (Fig. 5.3.6 pos. B) to set zero value by 45° gauge.
- Turn on the cutter rotation.
- Place material sample in the guide rails (the material should have edges in the right angle) and hold it tight close to the guide rails by hand.
- Using the screws (Fig. 5.3.6. pos. C), slowly lower the entire working table with the sample downward towards the rotating cutter.
- When the cutter first touches the material (this can be heard), stop lowering the table and lift it a bit.
- In this position, secure the table with nuts (Fig. 5.3.6. pos. A)
- Now the table is re-adjusted to the right values. Perform a control test.

## ACCESSORIES

### 7.1 Added tables

The machine UZ30 can be equipped with additional left output and right input table (ref. 25908). The length of the tables is 2x 1,000 mm. Each table is equipped with an adjustable ruler. Assemble the tables according to Fig 7.1.1.

Fig. 7.1.1.

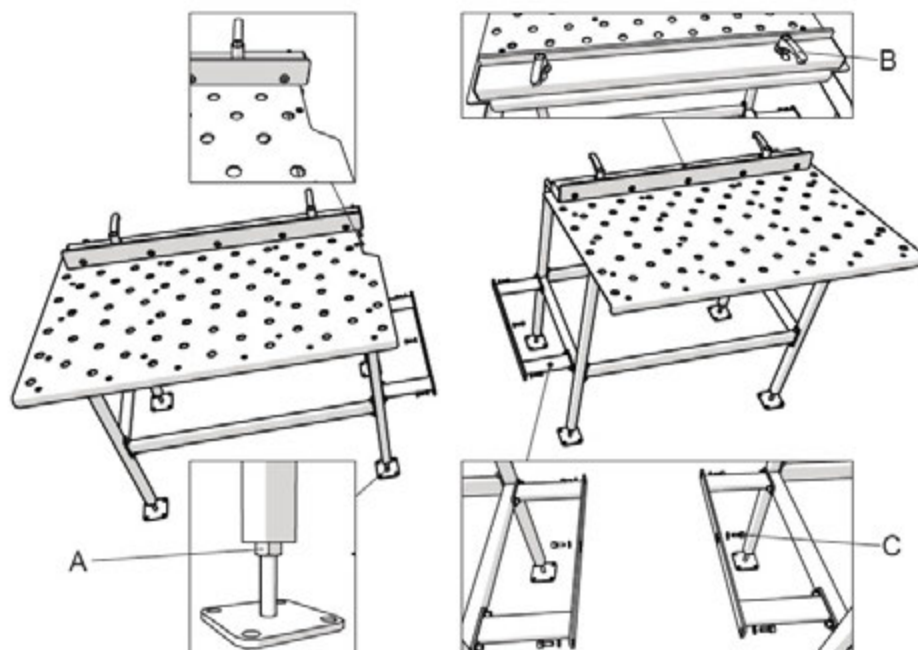

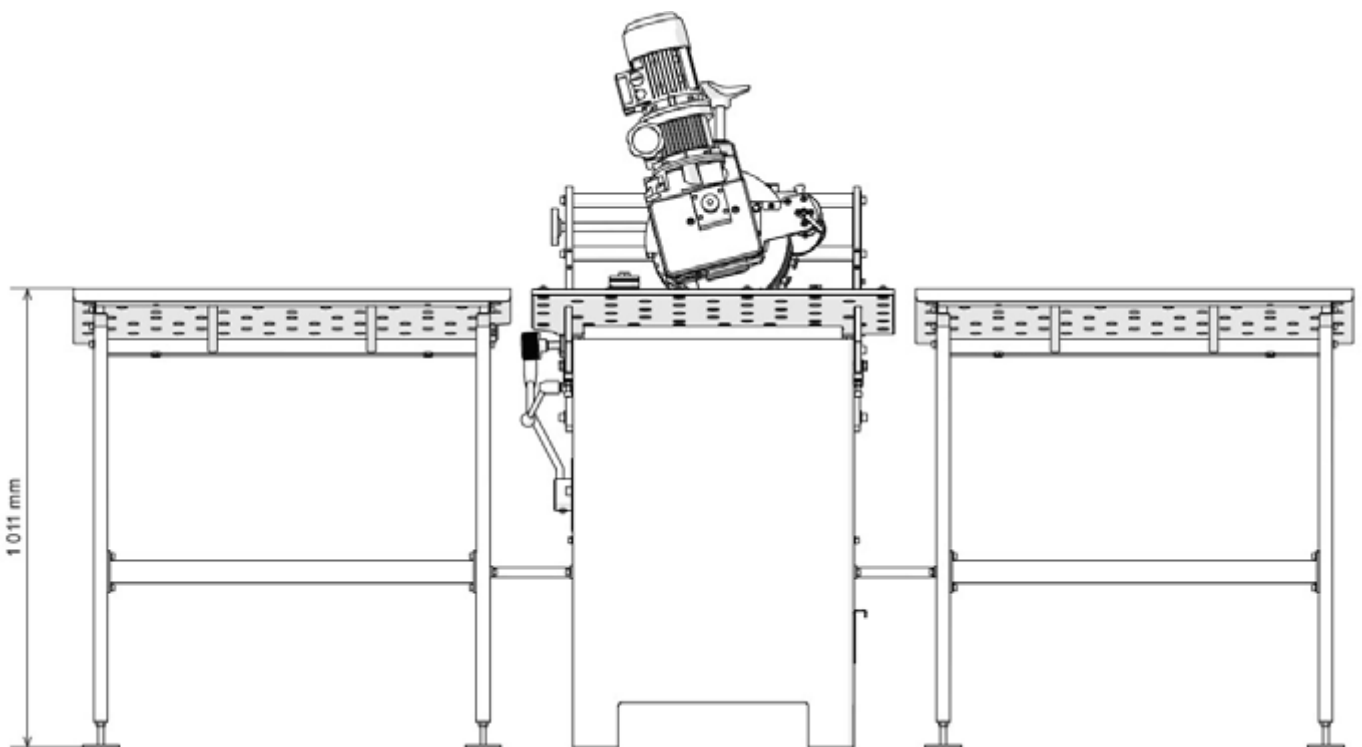
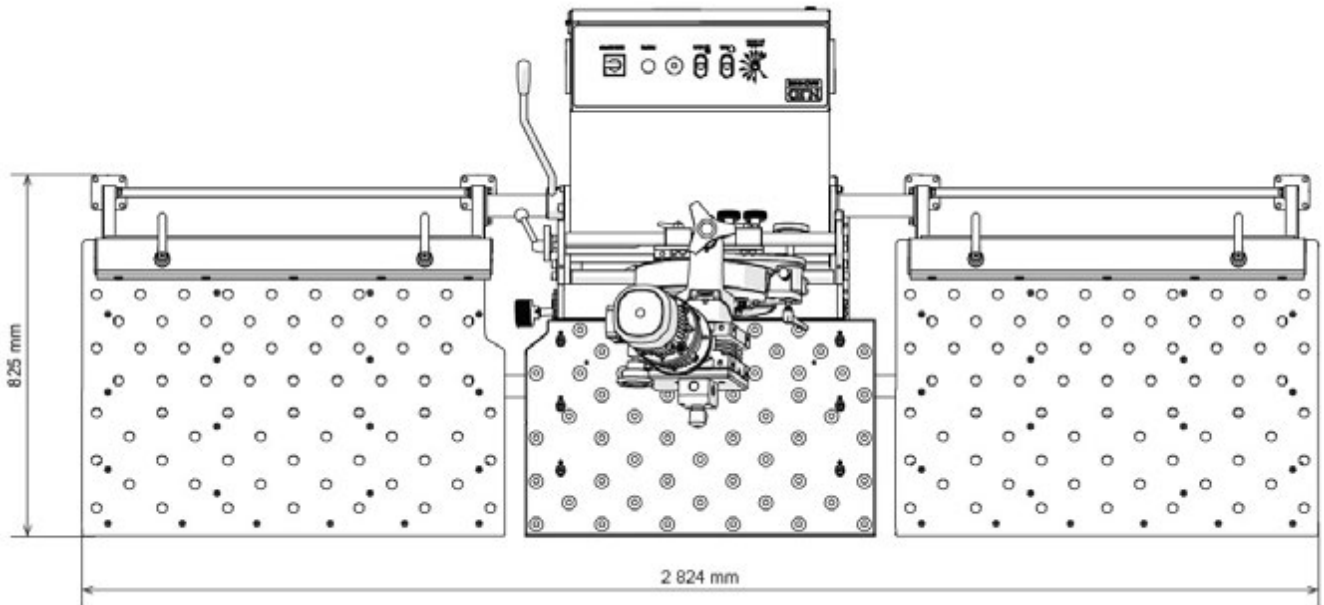



**Important:** Caution when installing the adjustable support rulers (position B Fig. 7.1.1.). Shorter ruler must be mounted on the left table provided with a recess for easier access to regulate the angle and the sliver, as indicated in Fig. 7.1.1.

The tables are mounted by the attached screws (position C Fig. 7.1.1.) on the ready threads at the sides of the UZ30 machine (Fig 7.1.2.). After mounting, the height of the tables need to be centred. To this purpose, use the adjusting table legs (position A Fig. 7.1.1.) .

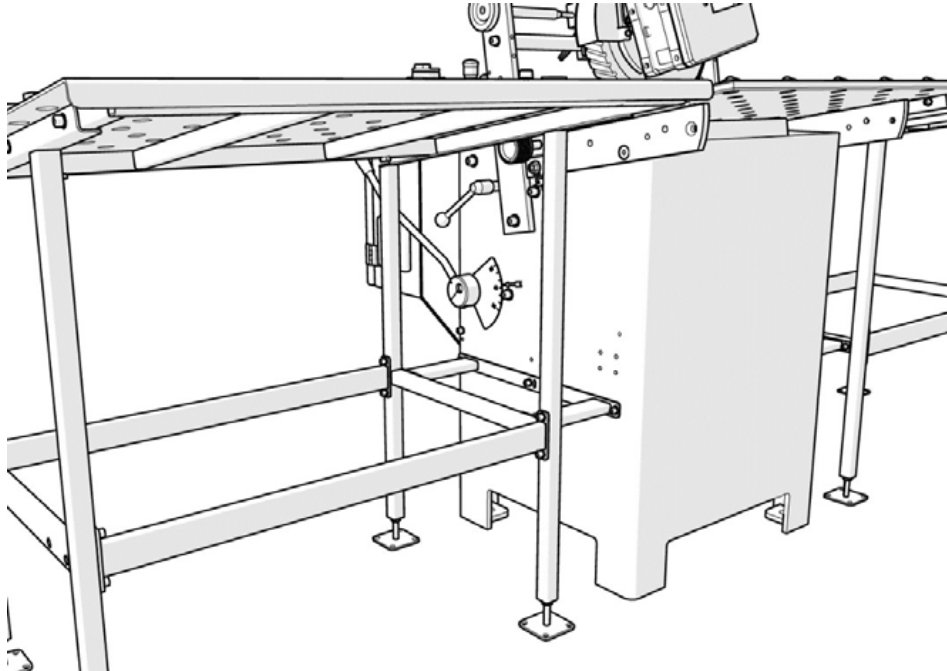
Fig. 7.1.2.



## 7.2 Fixture for pipe bevelling

The machine UZ30 can also be used for external bevelling of pipes. The fixture (ref. 25 902) can be used to bevel pipes of diameters ranging from 105 to 156 mm. The maximum pipe length is 1,000 mm. The fixture is mounted on prepared threaded holes (Fig. 7.2.1.)

Before using, it is necessary to set the proper position of the feed wheel, as advised in Chapter 5.3. Preliminary adjustments - Setting the inclination and the right / left position of the feed wheel.

**Important:** The wheel must be adjusted so that it automatically and continuously rotates the pipe around its axis while holding on to her in contact with the vertical guide rail. This position will always be different according to the pipe diameter.

Fig. 7.2.1.

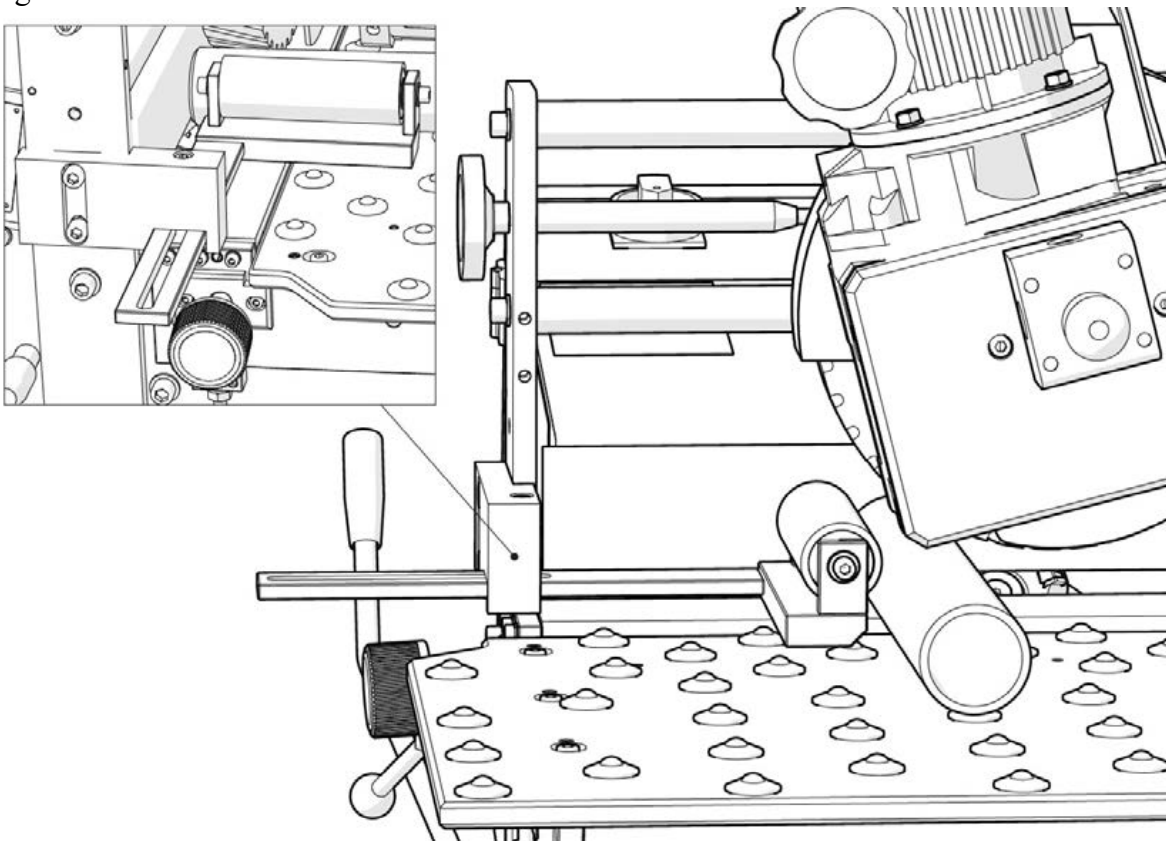

**When operating the machine in areas with particularly dangerous effects of AD and more, it is necessary to increase the protection of the machine against electrical shock!**

**Electrical energy** - if failures occur, electrical power needs to be turned off immediately.

Works on electrical equipment may only be performed by electrician - specialist or his subordinates supervised by this expert to make sure that these works were carried out according to the electrical procedures.



All parts that maintenance and repairs are performed on must be energized. These disconnected parts must be checked by a two-pole meter to make sure that no voltage is applied, and then these parts must be grounded and side parts that are energized to isolated!

Switching off the voltage must be performed by the main switch in position "0", disconnecting the machine from the power.



Electrical equipment needs to be checked regularly or tested, if needed. Any deficiencies, loose connections, or burnt cables, must be replaced immediately.

## SPARE PARTS

### 8.1 How to order spare parts

Orders of spare parts shall contain the following information:

- machine type;
- serial number;
- description of the required part, number of group and part position number
- quantity.

**8.2. Most worn out parts:**

Order No.	Description	Figure
		
<b>25917</b>	lapping stone	
<b>25912</b>	lapping head insert	
<b>25915</b>	lapping head screw	
<b>25903</b>	Feed wheel	
<b>Alvania</b>	lubricant grease for the machine UZ20	

**8.3 Wiring diagram and list of parts**

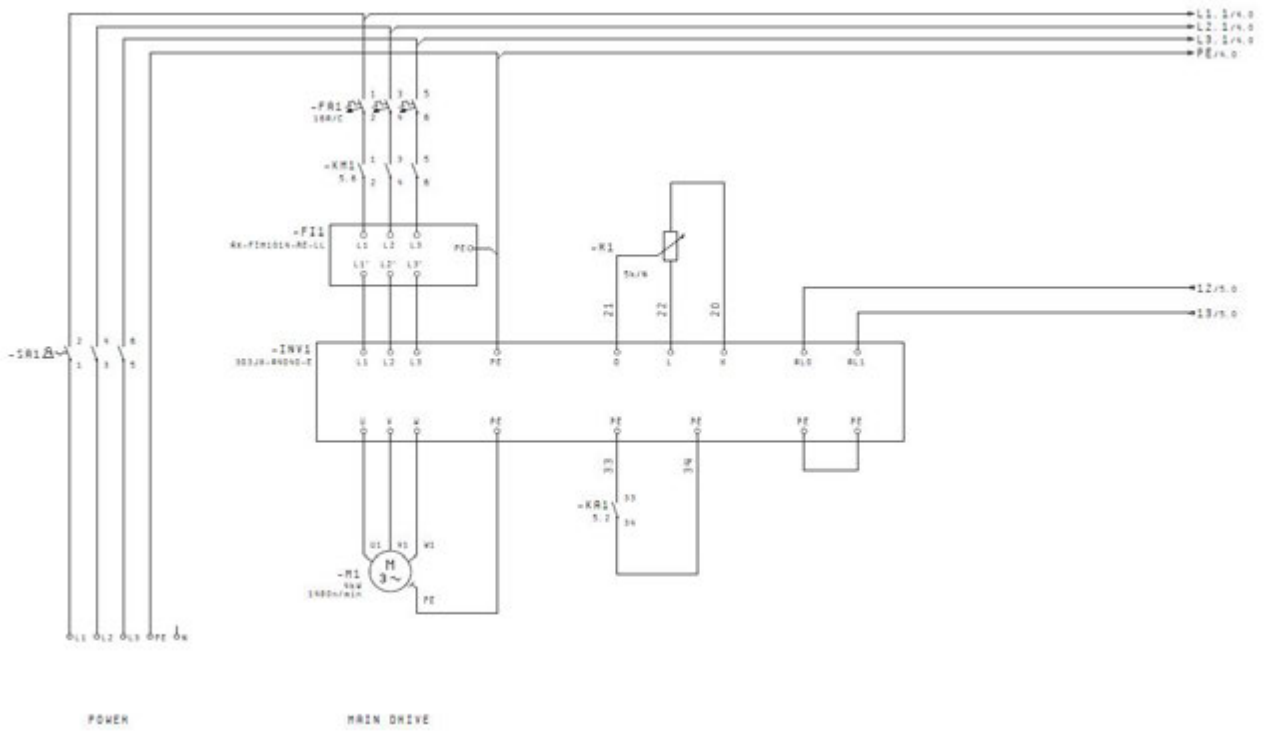

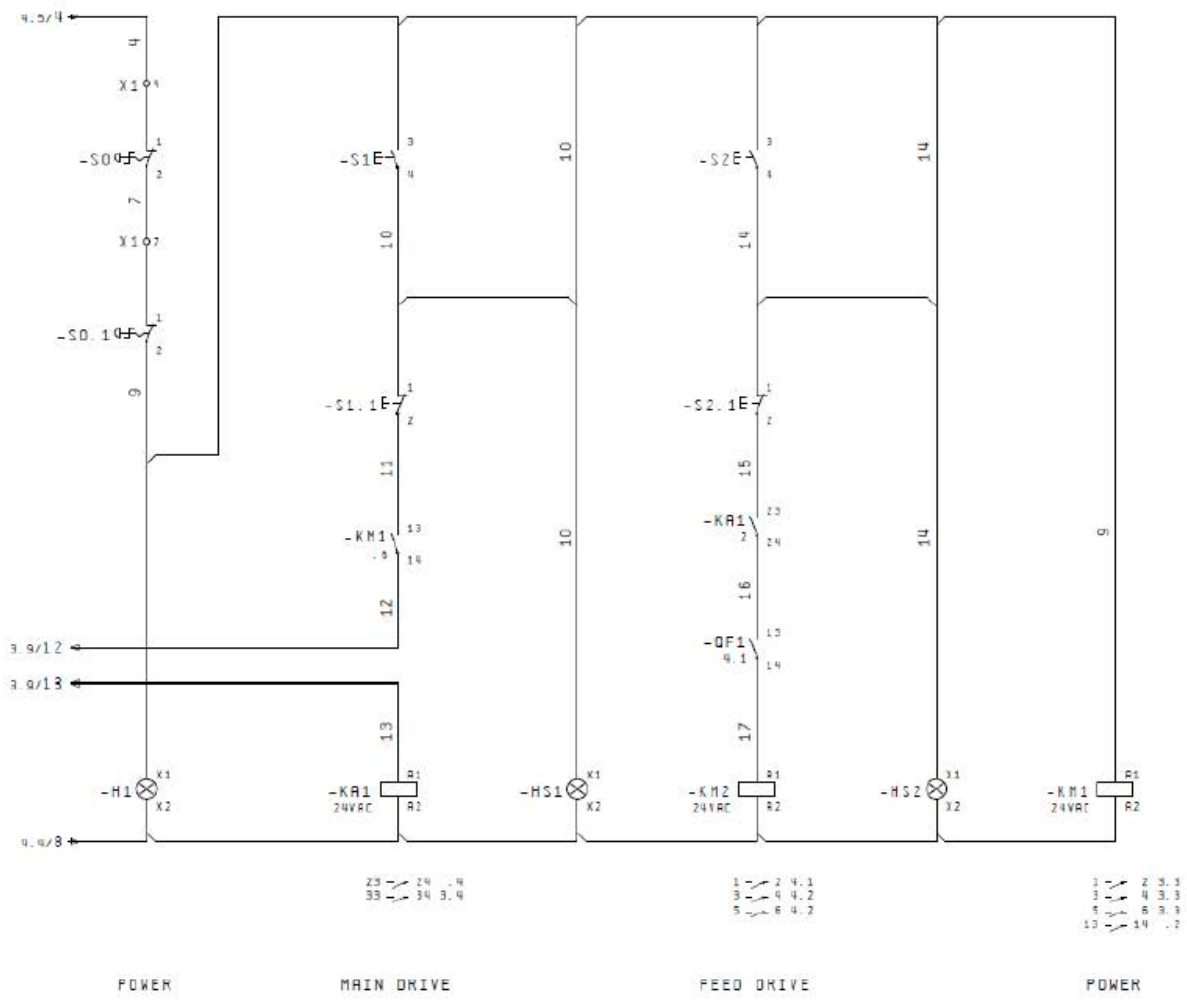
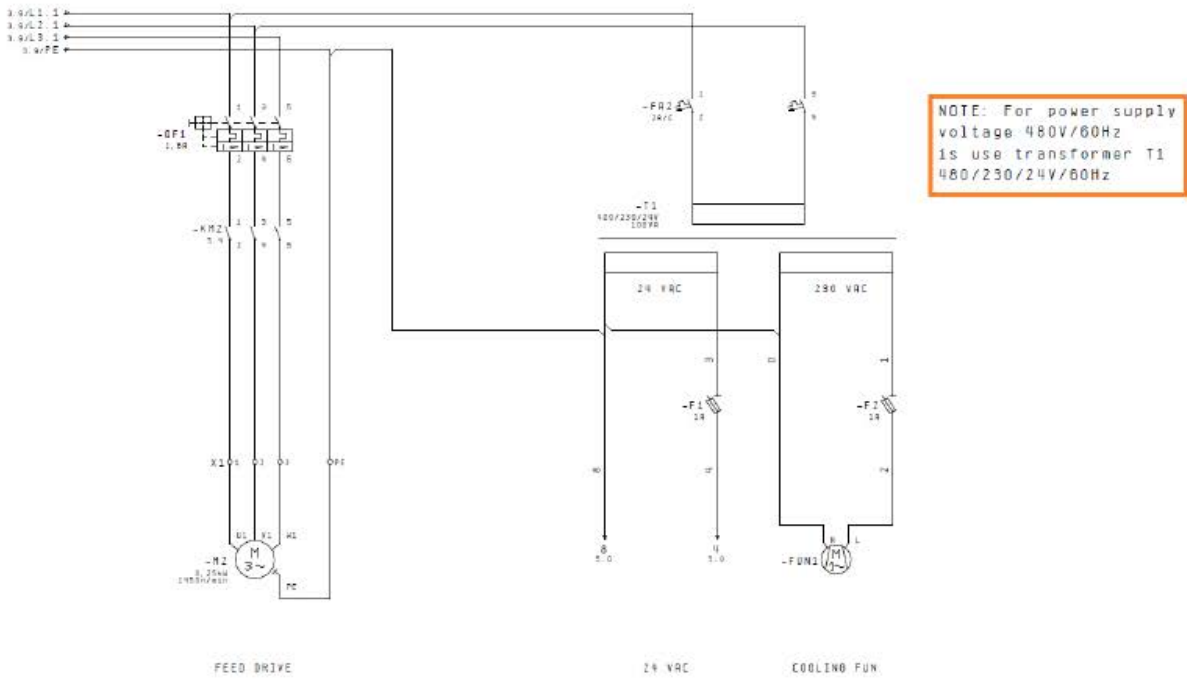

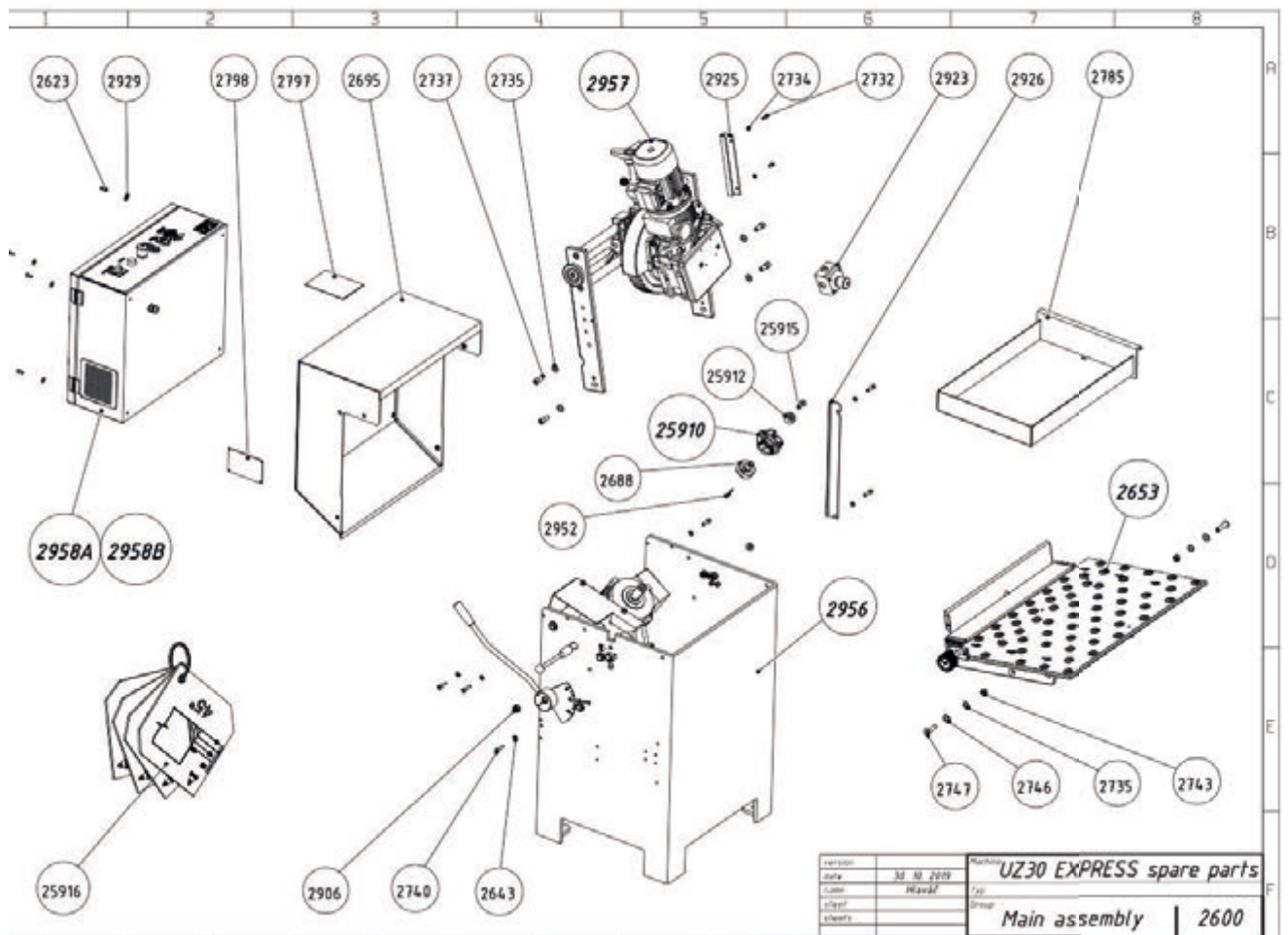

### UZ30 EXPRESS SPARE PARTS

drawing no. 2600 Main assembly

Number	Fig	Part name	Note	Pcs
	2653	working table	see assembly list 2653 Working table	1
	2956	main frame	see assembly list 2956 Main frame	1
	2957	workpiece drive	see assembly list 2957 Workpiece drive	1
A	2958A	complete electrocabinet	3x400V 50Hz / 3x480V 60Hz see assembly list 2958 Electro-cabinet	1
B	2958B	complete electrocabinet	3x230V 60Hz see assembly list 2958 Electro-cabinet	1
0	25910	milling head	see assembly list 25910 Milling head	1
2	25912	milling head ring		1
5	25915	milling head screw		1
6	25916	set of scales		1
9.2623	2623	screw		4
9.2643	2643	washer		6
9.2688	2688	adapter		1
9.2695	2695	back cover		1
9.2732	2732	screw		2
9.2734	2734	washer		2
9.2735	2735	washer		6
9.2737	2737	screw		4
9.2740	2740	screw		6
9.2743	2743	nut		2
9.2746	2746	spring		2
9.2747	2747	screw		2
9.2785	2785	drawer		1
9.2797	2797	label		1
9.2798	2798	type label		1
9.2906	2906	nut		2
9.2923	2923	button		1
9.2925	2925	cable holder		1
9.2926	2926	cable holder		1
9.2929	2929	washer		4
9.2952	2952	key		1

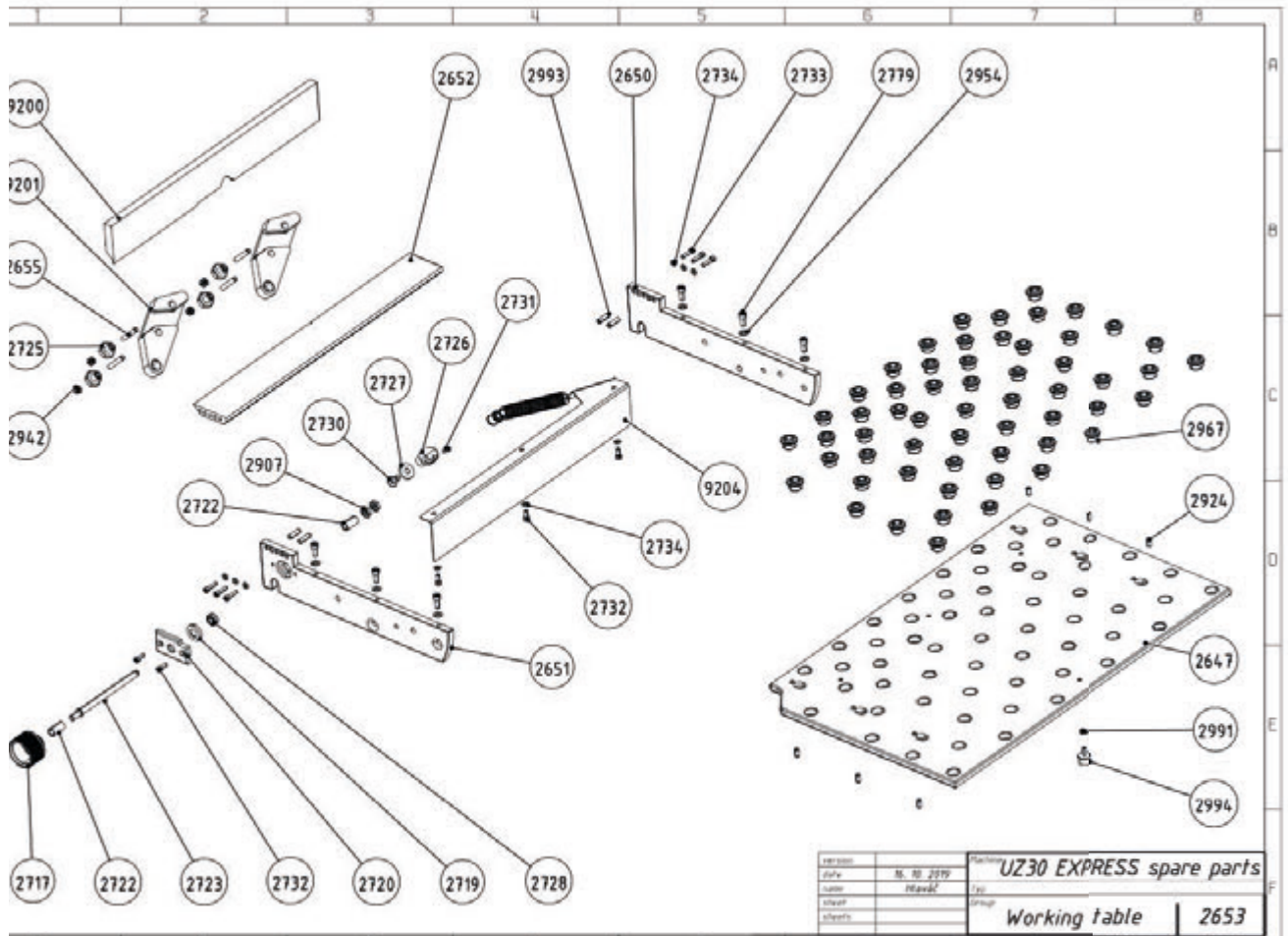

### UZ30 EXPRESS SPARE PARTS

drawing no. 2653 Working table

Number	Fig	Part name	Pcs	Number	Fig	Part name	Pcs
1.2647	2647	working desk	1	25999.9201	9201	lever	2
1.2650	2650	side bar A	1	25999.9204	9204	covering sheet metal	1
1.2651	2651	side bar B	1				
1.2652	2652	traverse	1				
1.2655	2655	screw	4				
1.2717	2717	control wheel	1				
1.2719	2719	ring	1				
1.2720	2720	covering plate	1				
1.2722	2722	ring	1				
1.2723	2723	adjusting screw	1				
1.2725	2725	nut	4				
1.2726	2726	peg	1				
1.2727	2727	washer	1				
1.2728	2728	spherical bearing	1				
1.2730	2730	screw	1				
1.2731	2731	screw	1				
1.2732	2732	screw	5				
1.2733	2733	screw	6				
1.2734	2734	washer	9				
1.2779	2779	screw	6				
1.2907	2907	nut	1				
1.2924	2924	screw	6				
1.2942	2942	nut	4				
1.2954	2954	washer	6				
1.2967	2967	ball bearing	57				
1.2991	2991	nut	1				
1.2993	2993	pin	4				
1.2994	2994	stopper	1				
1.9200	9200	support plate	1				

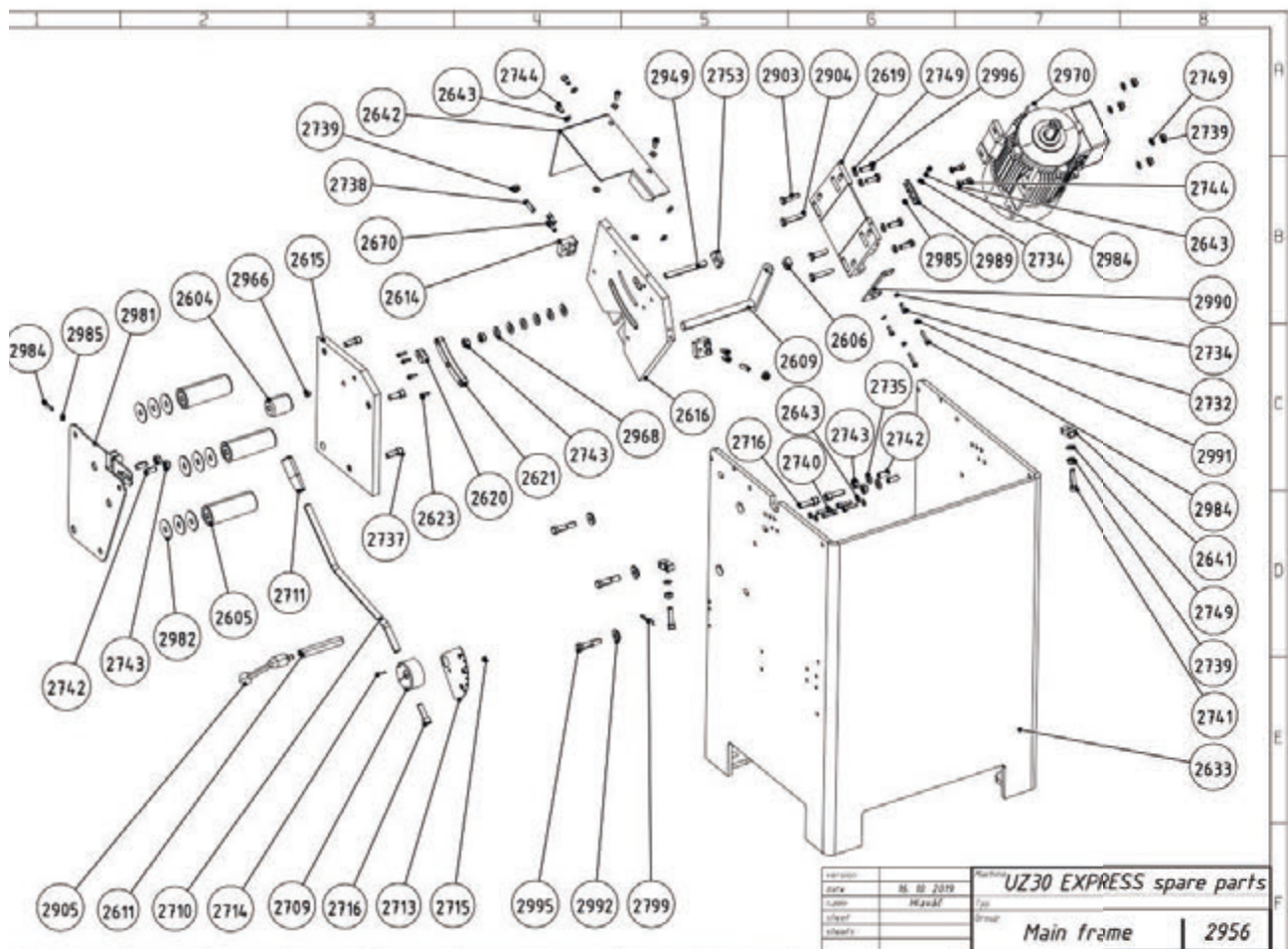

### UZ30 EXPRESS SPARE PARTS

drawing no. 2956 Main frame

Fig	Part name	Pcs	Number	Fig	Part name	Pcs
2604	supporting roll	1	25999.2738	2738	screw	2
2605	board's supporting roll	3	25999.2739	2739	nut	8
2606	block	1	25999.2740	2740	screw	4
2609	lever	1	25999.2741	2741	screw	2
2611	lever axis	1	25999.2742	2742	screw	4
2614	stopper	2	25999.2743	2743	nut	6
2615	board	1	25999.2744	2744	screw	6
2616	board	1	25999.2749	2749	washer	10
2619	adapter	1	25999.2753	2753	safety block	1
2620	sliding block	1	25999.2799	2799	indicator symbol	1
2621	sliding block	1	25999.2903	2903	screw	2
2623	screw	4	25999.2904	2904	screw	2
2633	base	1	25999.2905	2905	lever	1
2641	stopper	2	25999.2949	2949	screw bolt	1
2642	sheet metal	1	25999.2966	2966	plug	1
2643	washer	14	25999.2968	2968	spring	6
2670	screw	4	25999.2970	2970	engine	1
2709	grip	1	25999.2981	2981	sheet metal	1
2710	rod	1	25999.2982	2982	washer	9
2711	handle	1	25999.2984	2984	screw	2
2713	scale	1	25999.2985	2985	nut	1
2714	pin	1	25999.2989	2989	shim	1
2715	screw	1	25999.2990	2990	shim	1
2716	screw	2	25999.2991	2991	screw	2
2732	screw	2	25999.2992	2992	washer	3
2734	washer	2	25999.2995	2995	screw	3
2735	washer	2	25999.2996	2996	screw	4
2737	screw	3				



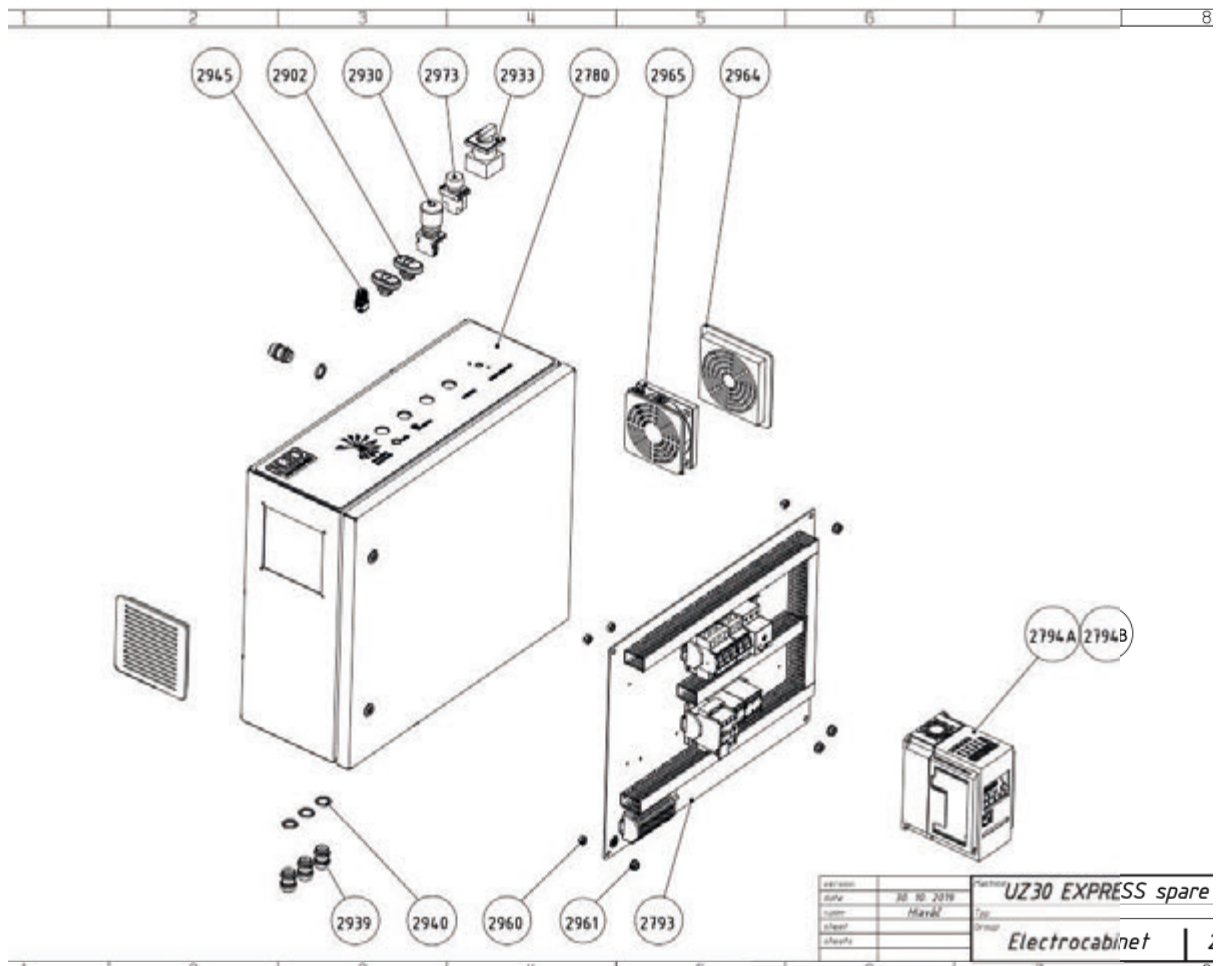

UZ30 EXPRESS SPARE PARTS		drawing no. 2958 Electrocabinet	
Fig	Part name	Fig	Note
2780	electrocabinet case	2780	
2793	electrics board	2793	
2794A	frequency converter	2794A	3x400V 50Hz / 3x480V 60Hz
2794B	frequency converter	2794B	3x230V 60Hz
2902	button	2902	
2930	button	2930	
2933	main switch	2933	
2939	grommet	2939	
2940	nut	2940	
2945	potentiometer	2945	
2960	nut	2960	
2961	nut	2961	
2964	grid with filter	2964	
2965	ventilator	2965	
2973	indicator	2973	

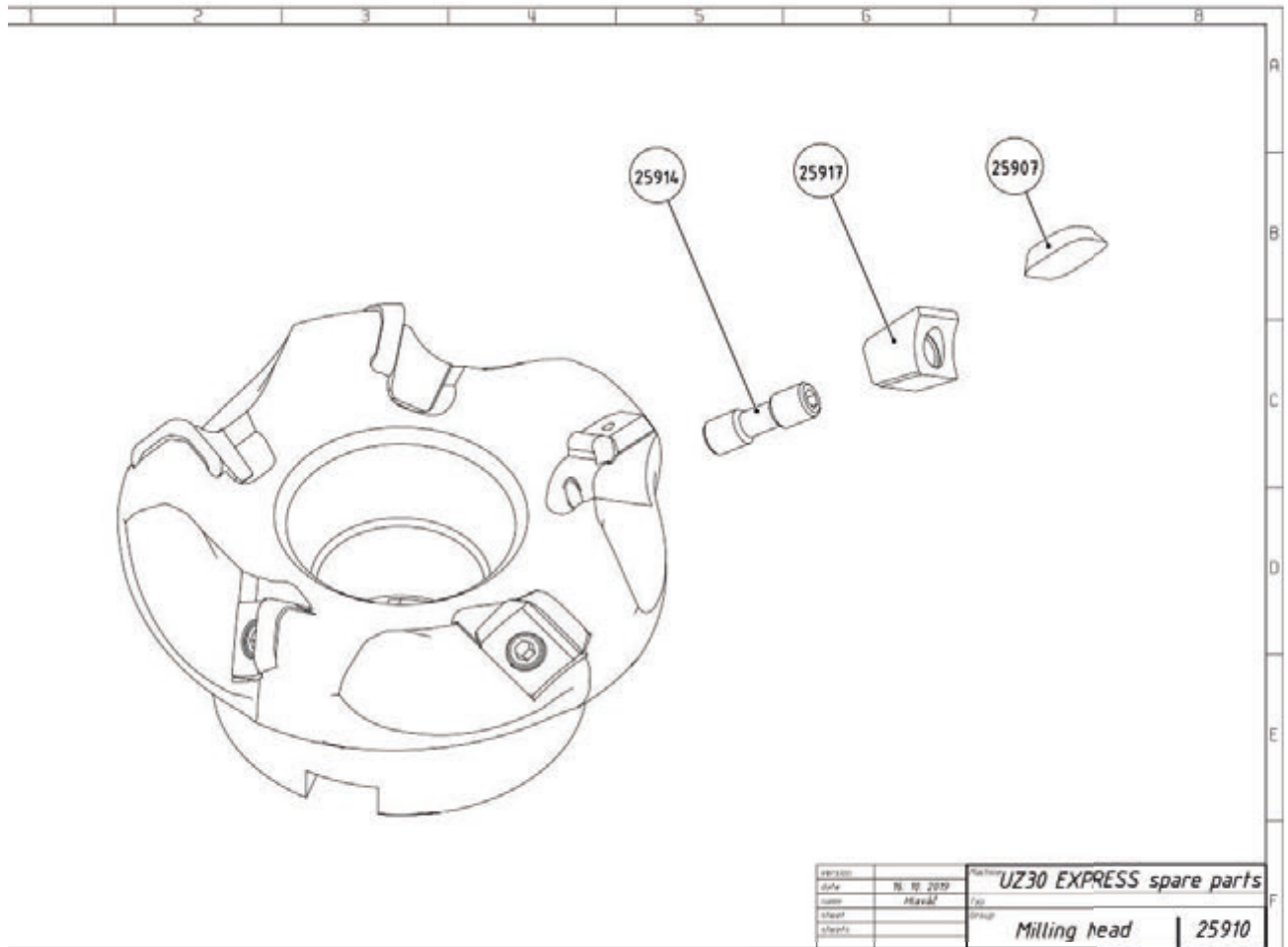

**UZ30 EXPRESS SPARE PARTS**

drawing no. **25910** Milling head

Fig	Part name	Note	Pcs
<b>25907</b>	insert		5
<b>25914</b>	screw		5
<b>25917</b>	clamping wedge		5

**A copy of this manual is supplied with every UZ30 Express machine. All rights reserved. No part of this publication may be reproduced without the previous consent granted by the company N.KO.**

**Manufacturer's and Distributor's Address:**

**N.KO spol. s r.o.  
a Member of Richtr Group  
Táborská 398/22  
293 01 Mladá Boleslav  
Czech Republic – Europe Union  
Phone: +420 326 772 001 fax: +420 326 774 279  
email:nko@nko.cz**

**USA Distributor's Address:**

**BEVELER USA INC.  
a Member of Richtr Group  
Business Office, Workshop, Warehouse**

**328 14th Street  
Ambridge, PA 15003**

**Toll Free Number: 1-800-973-1138  
Phone Ambridge (PA) office: 1-412-452-2563  
email:[service@bevelerusa.com](mailto:service@bevelerusa.com)**