



SUBMITTAL DATA

TM09D6HDI
9000 BTU/H Slim Duct (HS) Heat Pump System

Job Name

Location

Date

Purchaser

Engineer

Submitted to

For

Unit Designation

Schedule No.



YBE1FB5F



TM09D6HDI



XE72-44/E (Optional)

GENERAL FEATURES

- Compact and Quiet Design
- Slim Line Construction
- High Static E.S.P Capability-Adjustible
- Internal Condensate Drain Pump
- Flexible Return Air From Bottom Or Rear
- Wireless Remote with LCD Display Included
- Low Ambient Cooling and Heating
- Coil Copper Tube / Aluminum Fin
- Blue Colored Fin - 500 Hrs Salt Spray Tested
- New R32 Refrigerant with Refrigerant Sensor

SPECIFICATIONS, FEATURES & FUNCTION SUMMARY

			HEAT PUMP	FEATURES & FUNCTIONS SUMMARY		
Indoor Model			TM09D6DCI		Wired Controller Interface	Yes
SYSTEM PERFORMANCE					WiFi Included	No
Cooling Capacity	Nominal	Btu/h	9,000		Indoor Fan Type	Centrifugal
	Rated Capacity @95°F	Btu/h			Multi Fan Speeds	4 Speeds
Heating Capacity	Nominal	Btu/h	9,000		Indoor Unit Display	No
	Rated Capacity @47°F	Btu/h			Auxiliary Electrical Heater	No
	Rated Capacity @17°F	Btu/h			Ventilation (Outdoor Air)	No
	Rated Capacity @5°F	Btu/h			REMOTE CONTROLLER FUNCTIONS	
SEER2			System Performance Based on the Connected Outdoor Unit Performance		Auto Mode	Yes
EER2					Auto Fan	Yes
HSPF2					Auto Swing (Horizontal Auto Swing)	No
COP @5°F					Auto Swing - 180° (Vertical Auto Swing)	No
Cooling Temperature Range		°F			Clock	Yes
Heating Temperature Range		°F			Dry Mode	Yes
Refrigerant Type			R32		Dry Anti-Mildew (X-Fan) Mode	Yes
INDOOR UNIT			TM09D6DCI		Energy Saving Mode	Yes
Air flow (Min-Max)		CFM	188 - 324		Dirty Filter Alert	No
External Static Pressure (Max)		In W.c.	0.6		Fan Speed Control (7 Speeds)	Yes
Sound Pressure Level (Min - Max)		dB(A)	25 - 38		I Feel Function	Yes
Dehumidification		pt/hr	1.69		Privacy Lock	Yes
External Dimensions (L x D x H)		in	32-43/64 x 29-11/16 x 11-13/16		Quiet Mode	No
Package Dimension (L x W x H)		in	35-5/16 x 31-13/16 x 14-11/16		Room Temperature Display	No
Net Weight		lbs	70.6		Sleep Mode	Yes
Gross Weight		lbs	83.8		3 Sleep Mode Options	No
REFRIGERANT PIPING					Timer Mode	Yes
Line Set Sized by the Indoor Unit (Liquid - Gas) - Flared Connections		in	1/4 - 3/8		Turbo Mode Display	Yes
ELECTRICAL					On/Off Control	No
Power Supply			208-230V / 1Ph / 60Hz (Powered by the Outdoor Unit)		Freeze Guard Mode	Yes
					Power Failure Mode	Yes

FAN PERFORMANCE

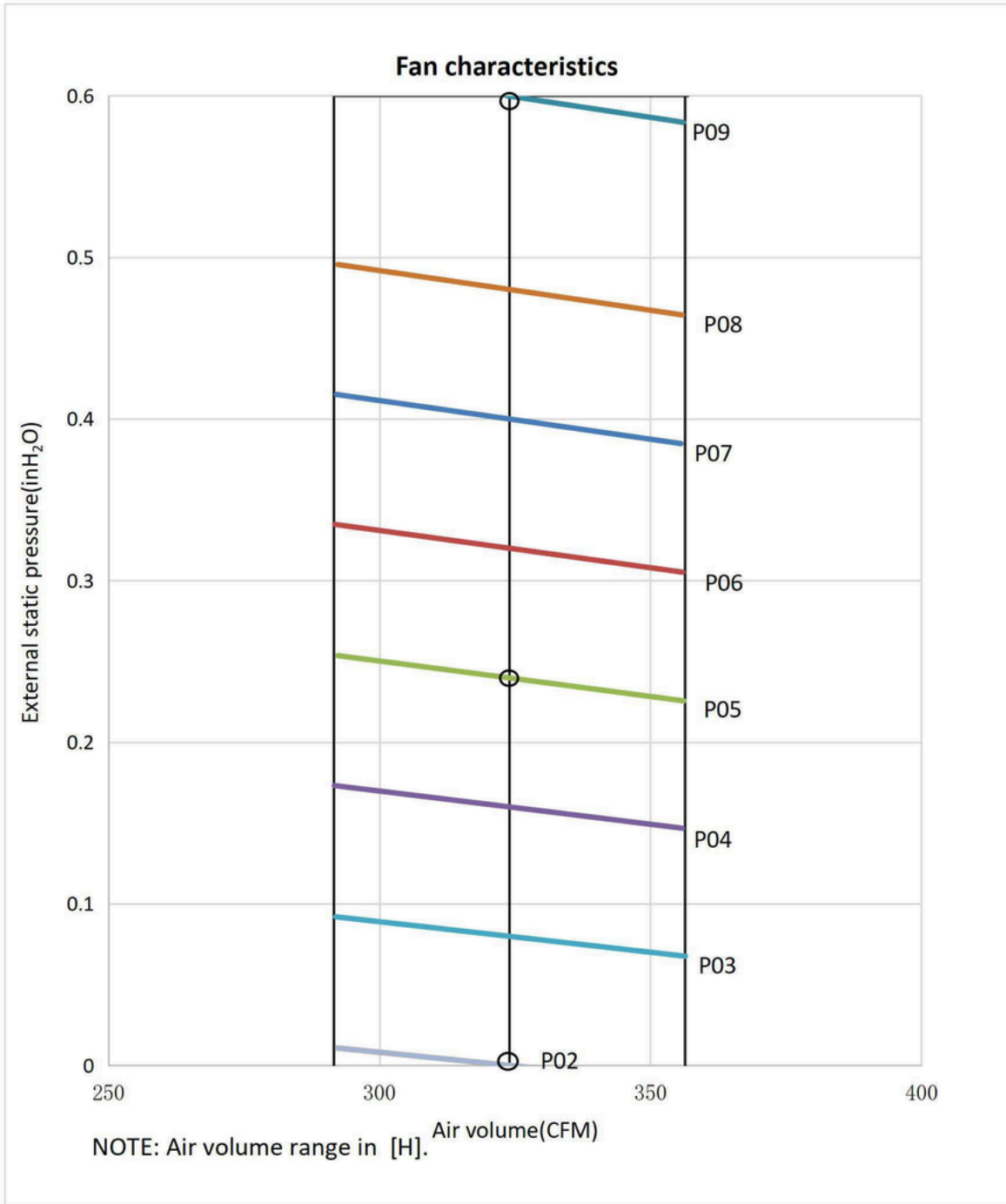

NOTE:

The static pressure is adjusted using the wired controller. Refer to the wired controller instruction manual for more information.

DIMENSIONS & CLEARANCES

INDOOR UNIT

Unit: inch

TM09D6HDI	
DIMENSIONS	
A	29 9/64
B	19 11/16
C	32 43/64
D	11 13/16
E	29 11/16
F	27 9/16
G	27 9/16

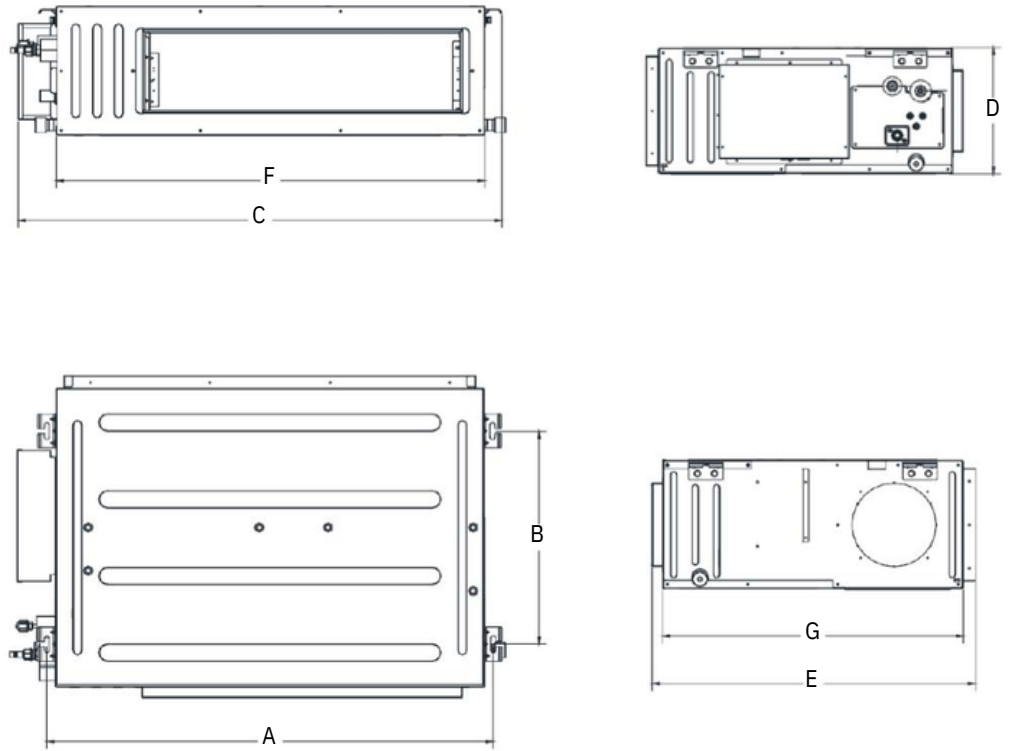

INDOOR UNIT

Minimum clearance

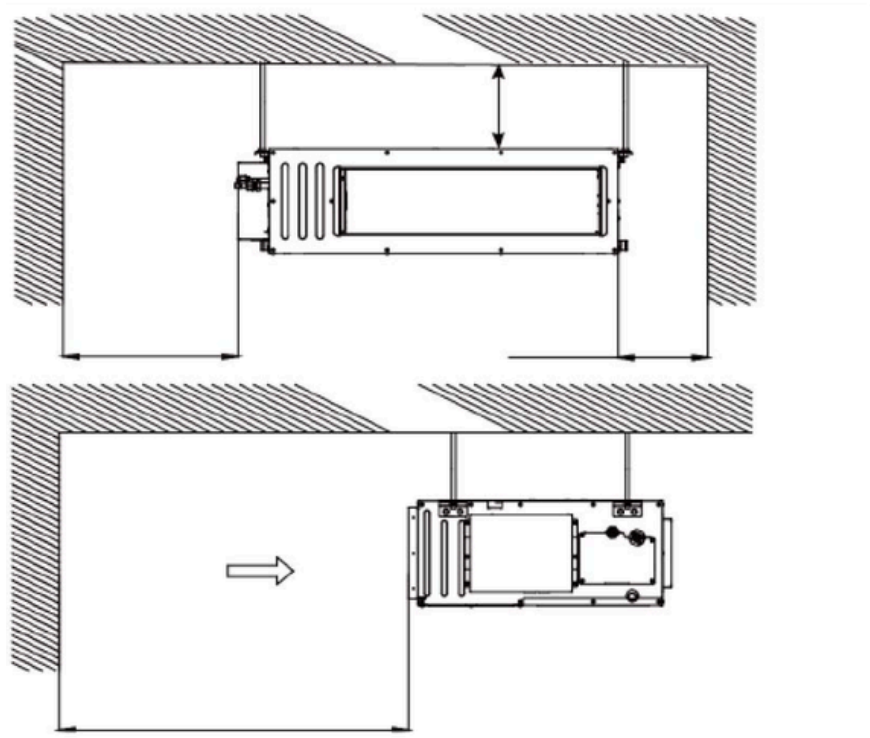

SUPPLY AND RETURN AIR OPENING DIMENSIONS

SUPPLY AIR OUTLET

Unit: inch

TM09D6HDI	
DIMENSIONS	
A	7-5/8
B	17-3/4
C	1

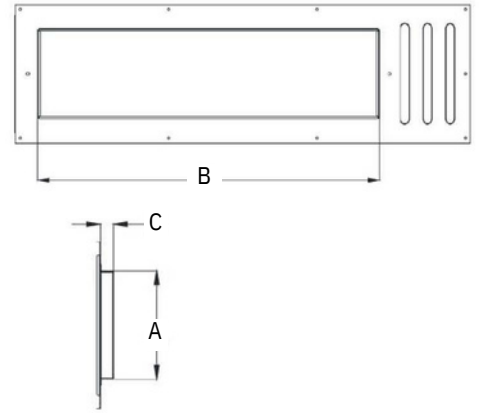
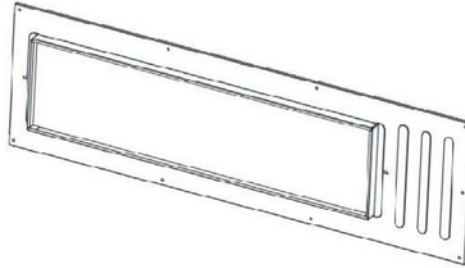

RETURN AIR INLET

Unit: inch

TM09D6HDI	
DIMENSIONS	
D	10-3/8
E	26
F	1-1/8

