

# TQSOT



## Service Manual



## Table of Contents

|   |    |
|---|----|
| <b>Part I : Technical Information</b> .....                 | 1  |
| <b>1. Summary</b> .....                                     | 1  |
| <b>2. Specifications</b> .....                              | 2  |
| 2.1 Specification Sheet.....                                | 2  |
| 2.2 Operation Characteristic Curve .....                    | 4  |
| 2.3 Capacity Variation Ratio According to Temperature ..... | 4  |
| 2.4 Noise Curve.....  | 5  |
| 2.5 Cooling and Heating Data Sheet in Rated Frequency ..... | 5  |
| <b>3. Outline Dimension Diagram</b> .....                   | 6  |
| 3.1 Indoor Unit.....  | 6  |
| 3.2 Outdoor Unit.....                                       | 6  |
| <b>4. Refrigerant System Diagram</b> .....                  | 7  |
| <b>5. Electrical Part</b> .....                             | 8  |
| 5.1 Wiring Diagram.....                                     | 8  |
| 5.2 PCB Printed Diagram .....                               | 10 |
| <b>6. Function and Control</b> .....                        | 12 |
| 6.1 Remote Controller Introduction .....                    | 12 |
| 6.2 Ewpe Smart App Operation Manual .....                   | 17 |
| 6.3 Brief Description of Modes and Functions.....           | 18 |
| <br>  |    |
| <b>Part II : Installation and Maintenance</b> .....         | 27 |
| <b>7. Notes for Installation and Maintenance</b> .....      | 27 |
| <b>8. Installation</b> .....                                | 30 |
| 8.1 Installation Dimension Diagram.....                     | 30 |
| 8.2 Installation Parts-checking .....                       | 32 |
| 8.3 Selection of Installation Location.....                 | 32 |
| 8.4 Requirements for Electric Connection.....               | 32 |
| 8.5 Installation of Indoor Unit.....                        | 32 |
| 8.6 Installation of Outdoor Unit.....                       | 35 |
| 8.7 Vacuum Pumping and Leak Detection .....                 | 36 |
| 8.8 Check after Installation and Test Operation .....       | 36 |

|   |    |
|---|----|
| <b>9. Maintenance</b> .....                                 | 37 |
| 9.1 Precautions before Maintenance.....                     | 37 |
| 9.2 Error Code List.....                                    | 38 |
| 9.3 Troubleshooting for Main Malfunction .....              | 42 |
| 9.4 Troubleshooting for Normal Malfunction.....             | 56 |
| <b>10. Exploded View and Parts List</b> .....               | 58 |
| 10.1 Indoor Unit.....                                       | 58 |
| 10.2 Outdoor Unit.....                                      | 60 |
| <b>11. Removal Procedure</b> .....                          | 62 |
| 11.1 Removal Procedure of Indoor Unit .....                 | 62 |
| 11.2 Removal Procedure of Outdoor Unit .....                | 67 |
| <b>Appendix:</b> .....                                      | 72 |
| Appendix 1: Reference Sheet of Celsius and Fahrenheit ..... | 72 |
| Appendix 2: Configuration of Connection Pipe.....           | 72 |
| Appendix 3: Pipe Expanding Method .....                     | 73 |
| Appendix 4: List of Resistance for Temperature Sensor ..... | 74 |



## 2. Specifications

### 2.1 Specification Sheet

|                              |                                   |                 |                    |                          |
|------------------------------|-----------------------------------|-----------------|--------------------|--------------------------|
| Model                        |                                   |                 | TW18HQ3C2D(WIFI)   |                          |
| Product Code                 |                                   |                 | CB439011600_X40891 |                          |
| Power Supply                 | Rated Voltage                     | V~              | 208/230            |                          |
|                              | Rated Frequency                   | Hz              | 60                 |                          |
|                              | Phases                            |                 | 1                  |                          |
| Power Supply Mode            |                                   |                 | Outdoor            |                          |
| Cooling Capacity(Min~Max)    |                                   | Btu/h           | 18000(3412~20472)  |                          |
| Heating Capacity(Min~Max)    |                                   | Btu/h           | 19800(3412~21837)  |                          |
| Cooling Power Input(Min~Max) |                                   | W               | 1820(80~2350)      |                          |
| Heating Power Input(Min~Max) |                                   | W               | 2090(220~2350)     |                          |
| Cooling Power Current        |                                   | A               | 8.1                |                          |
| Heating Power Current        |                                   | A               | 8.5                |                          |
| Rated Input                  |                                   | W               | 2350               |                          |
| Rated Current                |                                   | A               | 12                 |                          |
| Air Flow Volume(SH/H/M/L)    |                                   | CFM             | 500/441/383/294    |                          |
| Dehumidifying Volume         |                                   | Pint/h          | 3.80               |                          |
| EER                          |                                   | (Btu/h)/W       | 9.89               |                          |
| COP                          |                                   | (Btu/h)/W       | 9.47               |                          |
| SEER                         |                                   |                 | 18.00              |                          |
| HSPF                         |                                   |                 | 9.00               |                          |
| Application Area             |                                   | yd <sup>2</sup> | 27.50-40.66        |                          |
| Indoor Unit                  | Model of indoor unit              |                 | TW18HQ3C2DI        |                          |
|                              | Indoor Unit Product Code          |                 | CB439N11600_X40891 |                          |
|                              | Fan Type                          |                 | Cross-flow         |                          |
|                              | Diameter Length(DXL)              |                 | inch               | Φ4 3/16X27 13/16         |
|                              | Fan Motor Cooling Speed(SH/H/M/L) |                 | r/min              | 1350/1200/1050/900       |
|                              | Fan Motor Heating Speed(SH/H/M/L) |                 | r/min              | 1300/1200/1100/900       |
|                              | Output of Fan Motor               |                 | W                  | 35                       |
|                              | Fan Motor RLA                     |                 | A                  | 0.37                     |
|                              | Fan Motor Capacitor               |                 | μF                 | 2.5                      |
|                              | Evaporator Form                   |                 |                    | Aluminum Fin-copper Tube |
|                              | Pipe Diameter                     |                 | inch               | Φ5/16                    |
|                              | Row-fin Gap                       |                 | inch               | 2-1/16                   |
|                              | Coil Length (LXDXW)               |                 | inch               | 28 1/8X1X12              |
|                              | Swing Motor Model                 |                 |                    | MP35CJ                   |
|                              | Output of Swing Motor             |                 | W                  | 2.5                      |
|                              | Fuse                              |                 | A                  | 3.15                     |
|                              | Sound Pressure Level(SH/H//M/L)   |                 | dB (A)             | 47/44/40/35              |
|                              | Sound Power Level(SH/H//M/L)      |                 | dB (A)             | 57/54/50/45              |
|                              | Dimension (WXHXD)                 |                 | inch               | 38 3/16X11 13/16X8 13/16 |
|                              | Dimension of Carton Box (LXWXH)   |                 | inch               | 40 7/8X15X12             |
| Dimension of Package (LXWXH) |                                   | inch            | 41X15X12 5/8       |                          |
| Net Weight                   |                                   | lb              | 30.9               |                          |
| Gross Weight                 |                                   | lb              | 37.5               |                          |

|                                 |   |        |                                 |  |
|---------------------------------|---|--------|---------------------------------|--|
| Outdoor Unit                    | Model of Outdoor Unit   |        | TW18HQ3C2DO                     |  |
|                                 | Outdoor Unit Product Code                                       |        | CB425W07400_X40891              |  |
|                                 | Compressor Manufacturer/Trademark                               |        | ZHUHAI LANDA COMPRESSOR CO.,LTD |  |
|                                 | Compressor Model  |        | QXA-B141zF030A                  |  |
|                                 | Compressor Oil  |        | RB68EP                          |  |
|                                 | Compressor Type   |        | Rotary                          |  |
|                                 | Compressor Locked Rotor Amp (L.R.A)                             | A      |                                 | 25   |
|                                 | Compressor RLA  | A      |                                 | 12.08  |
|                                 | Compressor Power Input  | W      |                                 | 1440   |
|                                 | Overload Protector  |        |                                 | 1NT11L-6233 or KSD115 <sup>°C</sup> or HPC115/95U1 |
|                                 | Throttling Method   |        |                                 | Electron expansion valve                           |
|                                 | Operation temp  | °F     |                                 | 60.8~86  |
|                                 | Ambient temp (cooling)  | °F     |                                 | 0~115  |
|                                 | Ambient temp (heating)  | °F     |                                 | -4~75  |
|                                 | Condenser Form  |        |                                 | Aluminum Fin-copper Tube                           |
|                                 | Pipe Diameter   | inch   |                                 | Φ3/8   |
|                                 | Rows-fin Gap  | inch   |                                 | 1-1/16   |
|                                 | Coil Length (LXDXW)   | inch   |                                 | 33 5/8X26X7/8                                      |
|                                 | Fan Motor Speed   | rpm    |                                 | 800  |
|                                 | Output of Fan Motor   | W      |                                 | 60   |
|                                 | Fan Motor RLA   | A      |                                 | 0.52   |
|                                 | Fan Motor Capacitor   | μF     |                                 | /  |
|                                 | Air Flow Volume of Outdoor Unit                                 | CFM    |                                 | 1883   |
|                                 | Fan Type  |        |                                 | Axial-flow   |
|                                 | Fan Diameter  | inch   |                                 | Φ20 1/2  |
|                                 | Defrosting Method   |        |                                 | Automatic Defrosting                               |
|                                 | Climate Type  |        |                                 | T1   |
|                                 | Isolation   |        |                                 | I  |
|                                 | Moisture Protection   |        |                                 | IPX4   |
|                                 | Permissible Excessive Operating Pressure for the Discharge Side | ISPG   |                                 | 550  |
|                                 | Permissible Excessive Operating Pressure for the Suction Side   | ISPG   |                                 | 240  |
|                                 | Sound Pressure Level (H/M/L)                                    | dB (A) |                                 | 57/-/-   |
| Sound Power Level (H/M/L)       | dB (A)  |        | 67/-/-                          |  |
| Dimension (WXHxD)               | inch  |        | 38X27 9/16X15 5/8               |  |
| Dimension of Carton Box (LXWXH) | inch  |        | 40 3/8X17 7/8X29                |  |
| Dimension of Package (LXWXH)    | inch  |        | 40 1/2X18X29 1/2                |  |
| Net Weight                      | lb  |        | 97                              |  |
| Gross Weight                    | lb  |        | 106.9                           |  |
| Refrigerant                     |   |        | R410A                           |  |
| Refrigerant Charge              | oz  |        | 45.86                           |  |
| Connection Pipe                 | Length  | ft     | 24.6                            |  |
|                                 | Gas Additional Charge   | oz/ft  | 0.2                             |  |
|                                 | Outer Diameter Liquid Pipe                                      | inch   | Φ1/4                            |  |
|                                 | Outer Diameter Gas Pipe   | inch   | Φ1/2                            |  |
|                                 | Max Distance Height   | ft     | 32.8                            |  |
|                                 | Max Distance Length   | ft     | 82                              |  |
|                                 | Note:The connection pipe applies metric diameter.               |        |                                 |  |

The above data is subject to change without notice; please refer to the nameplate of the unit.



## 2.4 Noise Curve

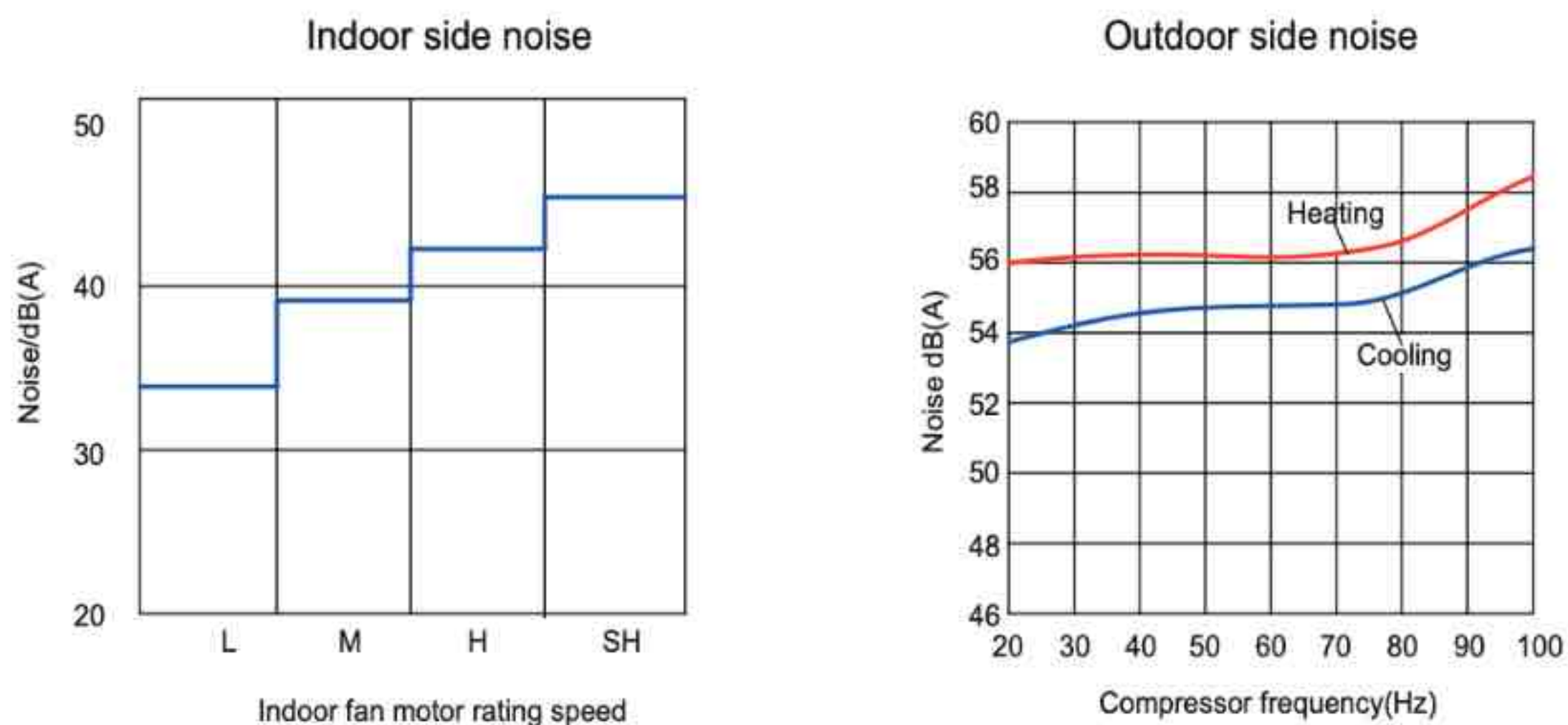

## 2.5 Cooling and Heating Data Sheet in Rated Frequency

Cooling:

| Rated cooling condition(°F) (DB/WB) |         | Model | Pressure of gas pipe connecting indoor and outdoor unit | Inlet and outlet pipe temperature of heat exchanger |                                | Fan speed of indoor unit | Fan speed of outdoor unit | Compressor revolution (rps) |
|-------------------------------------|---------|-------|---|---|--------------------------------|--------------------------|---------------------------|-----------------------------|
| Indoor                              | Outdoor |       |   | T1 (°F)   | T2 (°F)                        |                          |                           |                             |
| 80/66.9                             | 95/-    | 18K   | P (PSIG)<br>130~142                                     | in:46.4~51.8<br>out:51.8~57.2                       | in:167~181.4<br>out:98.6~118.4 | Super High               | High                      | 73                          |

Heating:

| Rated heating condition(°F) (DB/WB) |             | Model | Pressure of gas pipe connecting indoor and outdoor unit | Inlet and outlet pipe temperature of heat exchanger |                               | Fan speed of indoor unit | Fan speed of outdoor unit | Compressor revolution (rps) |
|-------------------------------------|-------------|-------|---|---|-------------------------------|--------------------------|---------------------------|-----------------------------|
| Indoor                              | Outdoor     |       |   | T1 (°F)   | T2 (°F)                       |                          |                           |                             |
| 70/60                               | 19.94/19.04 | 18K   | P (PSIG)<br>507~550                                     | in:167~181.4<br>out:98.6~113                        | in:33.8~37.4<br>out:35.6~42.8 | Super High               | High                      | 75                          |

**Instruction:**

T1: Inlet and outlet pipe temperature of evaporator

T2: Inlet and outlet pipe temperature of condenser

P: Pressure at the side of big valve

Connection pipe length: 24.6ft.



# 4. Refrigerant System Diagram

TW18HQ3C2D(WIFI)

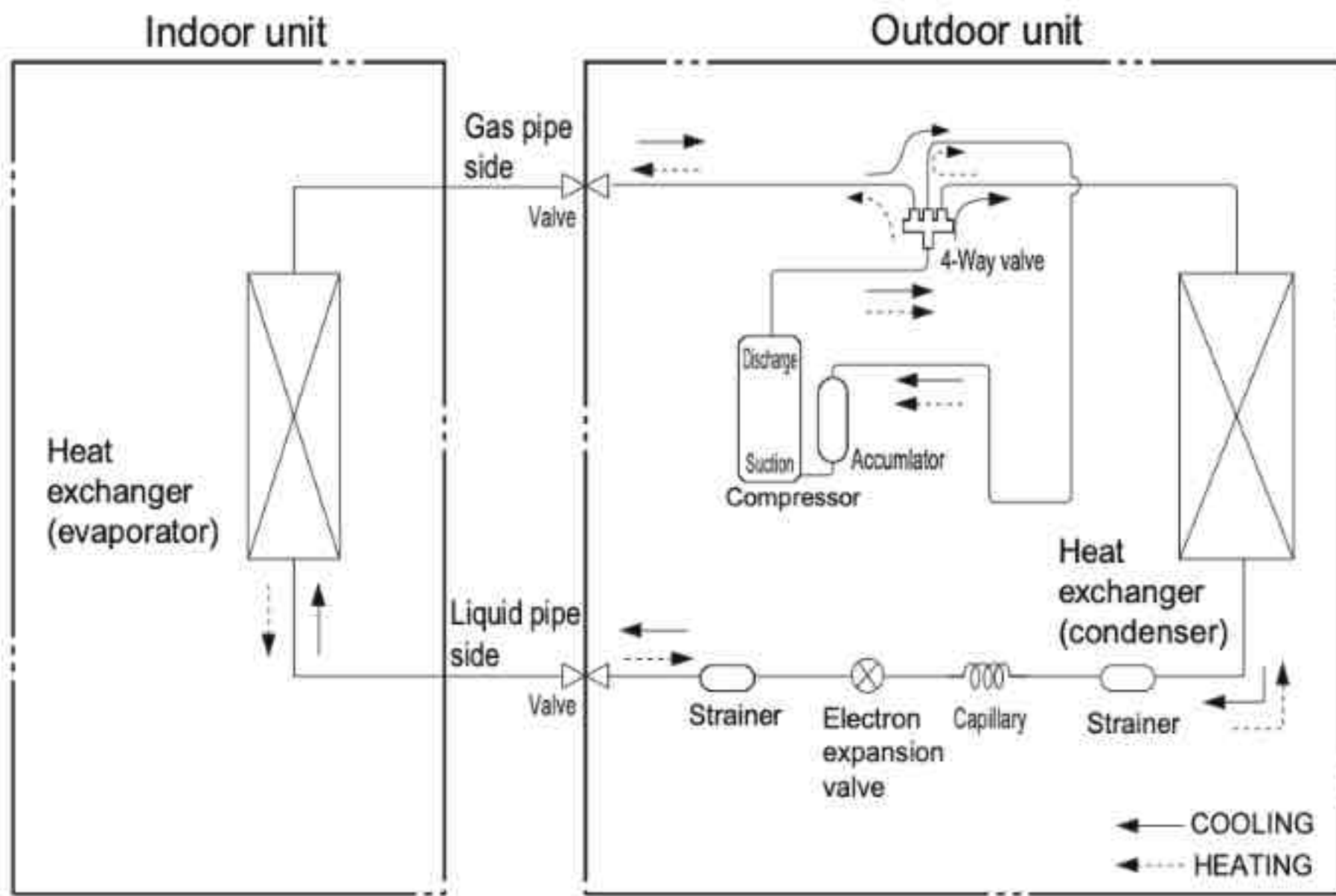

Connection pipe specification:  
Liquid pipe:1/4"  
Gas pipe:1/2"



• Outdoor Unit

TW18HQ3C2DO

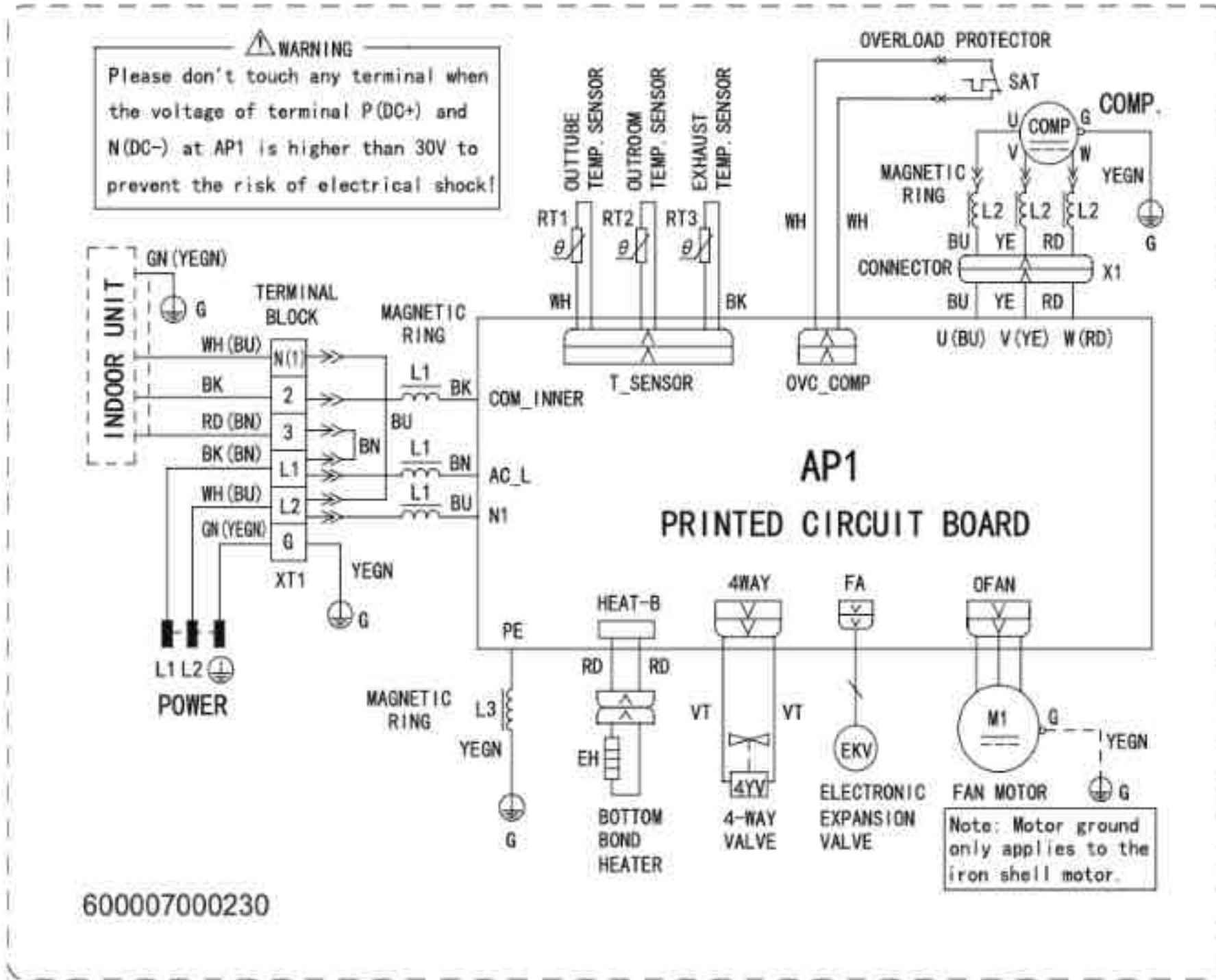

The above data is subject to change without notice. Please refer to the nameplate of the unit.



Outdoor Unit

• Top view

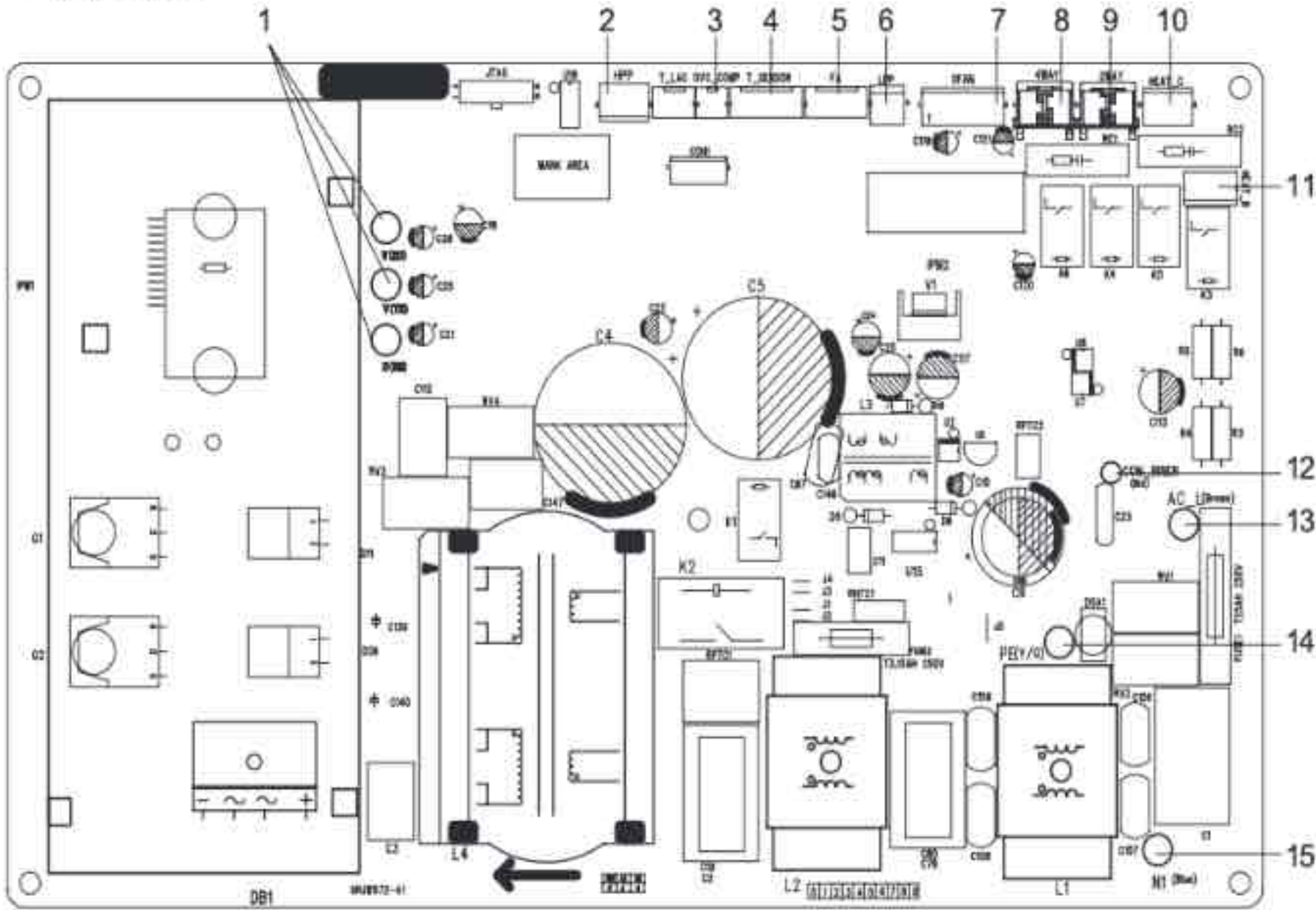

| No. | Name   |
|-----|--|
| 1   | Compressor three phase input interface       |
| 2   | Interface of system high pressure protection |
| 3   | Compressor overload protection interface     |
| 4   | Interface of temperature sensor              |
| 5   | Interface of electronic expansion valve      |
| 6   | Interface of system low pressure protection  |
| 7   | Interface of fan                             |
| 8   | 4-way valve interface                        |
| 9   | 2-way valve interface                        |
| 10  | Interface of electric heating for compressor |
| 11  | Interface of electric heating for chassis    |
| 12  | Communication interface                      |
| 13  | Interface of live wire                       |
| 14  | Interface of earthing wire                   |
| 15  | Interface of neutral wire                    |

• Bottom view

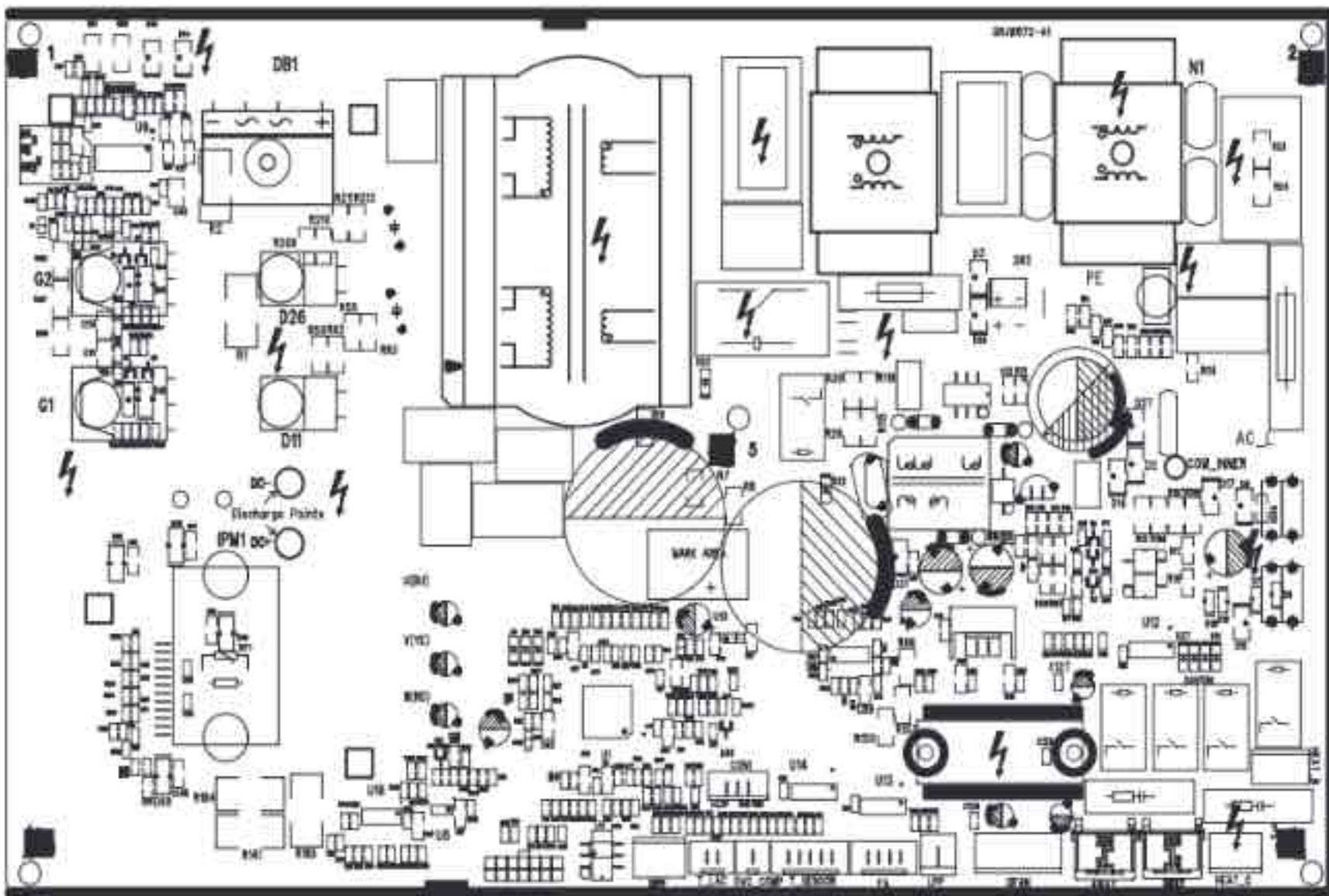



### 1. ON/OFF button

Press this button to turn on the unit. Press this button again to turn off the unit.

### 2. MODE button

Press this button to select your required operation mode.

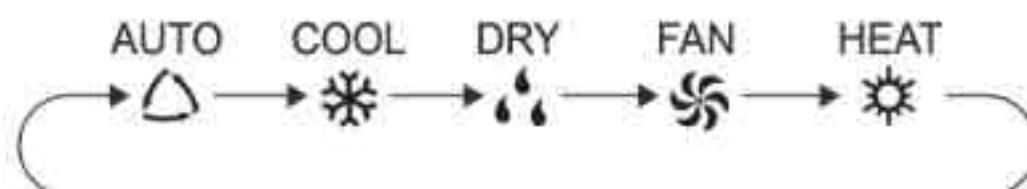

- When selecting auto mode, air conditioner will operate automatically according to ex-factory setting. Set temperature cant be adjusted and will not be displayed as well. Press "FAN" button can adjust fan speed. Press "SWING" button can adjust fan blowing angle.
- After selecting cool mode, air conditioner will operate under cool mode. Cool indicator on indoor unit is ON. (This indicator is not available for some models). Press "▲" or "▼" button to adjust set temperature. Press "FAN" button to adjust fan speed. Press "SWING" button to adjust fan blowing angle.
- When selecting dry mode, the air conditioner operates at low speed under dry mode. Dry indicator "💧" on indoor unit is ON. (This indicator is not available for some models). Under dry mode, fan speed cant be adjusted. Press "SWING" button to adjust fan blowing angle.
- When selecting fan mode, the air conditioner will only blow fan, no cooling and no heating. All indicators are OFF. Press "FAN" button to adjust fan speed. Press "SWING" button to adjust fan blowing angle.
- When selecting heating mode, the air conditioner operates under heat mode. Heat indicator on indoor unit is ON. (This indicator is not available for some models). Press "▲" or "▼" button to adjust set temperature. Press "FAN" button to adjust fan speed. Press "SWING" button to adjust fan blowing angle. (Cooling only unit wont receive heating mode signal. If setting heat mode with remote controller, press ON/OFF button cant start up the unit).

**Note:**

- For preventing cold air, after starting up heating mode, indoor unit will delay 1~5 minutes to blow air (actual delay time is depend on indoor ambient temperature).
- Set temperature range from remote controller: 16~30°C ; Fan speed: auto, low speed, medium speed, high speed.

### 3. FAN button

Pressing this button can set fan speed circularly as: auto (AUTO), low( 📶 ), medium( 📶 ), high( 📶 ).



**Note:**

- Under AUTO speed, air conditioner will select proper fan speed automatically according to ex-factory setting.
- Fan speed under dry mode is low speed.
- X-FAN function: Hold fan speed button in COOL or DRY mode, the icon "⊗" is displayed and the indoor fan will continue operation for a few minutes in order to dry the indoor unit even though you have turned off the unit. After energization, X-FAN OFF is defaulted. X-FAN is not available in AUTO, FAN or HEAT mode.

This function indicates that moisture on evaporator of indoor unit will be blown after the unit is stopped to avoid mould.

- Having set X-FAN function on: After turning off the unit by pressing ON/OFF button indoor fan will continue running for a few minutes. at low speed. In this period, Hold fan speed button to stop indoor fan directly.
- Having set X-FAN function off: After turning off the unit by pressing ON/OFF button, the complete unit will be off directly.

### 4. SWING button

Press this button can select up&down swing angle. Fan blow angle can be selected circularly as below:

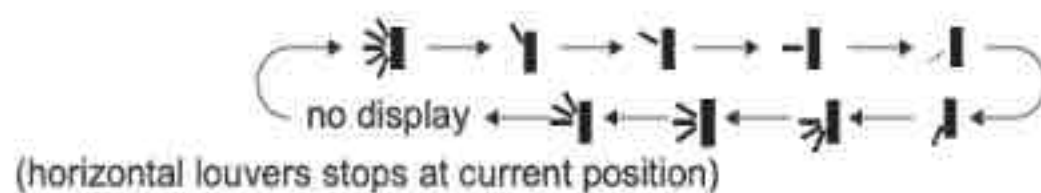

- When selecting "📶", air conditioner is blowing fan automatically. Horizontal louver will automatically swing up & down at maximum angle.
- When selecting "📶", "📶", "📶", "📶", "📶", air conditioner is blowing fan at fixed position. Horizontal louver will stop at the fixed position.
- When selecting "📶", "📶", "📶", air conditioner is blowing fan at fixed angle. Horizontal louver will send air at the fixed angle.
- Hold "📶" button above 2s to set your required swing angle. When reaching your required angle, release the button.

**Note:**

- "📶", "📶", "📶" may not be available. When air conditioner receives this signal, the air conditioner will blow fan automatically.

### 5. TURBO button

Under COOL or HEAT mode, press this button to turn to quick COOL or quick HEAT mode. "⚡" icon is displayed on remote controller. Press this button again to exit turbo function and "⚡" icon will disappear.

## 6. ▲/▼ button

- Press "▲" or "▼" button once increase or decrease set temperature 1°C. Holding "▲" or "▼" button, 2s later, set temperature on remote controller will change quickly. On releasing button after setting is finished, temperature indicator on indoor unit will change accordingly. (Temperature can't be adjusted under auto mode)
- When setting TIMER ON, TIMER OFF or CLOCK, press "▲" or "▼" button to adjust time. (Refer to CLOCK, TIMER ON, TIMER OFF buttons)

## 7. SLEEP button

Under COOL, HEAT or DRY mode, press this button to start up sleep function. "☾" icon is displayed on remote controller. Press this button again to cancel sleep function and "☾" icon will disappear.

## 8. TEMP button

By pressing this button, you can see indoor set temperature, indoor ambient temperature or outdoor ambient temperature on indoor units display. The setting on remote controller is selected circularly as below:

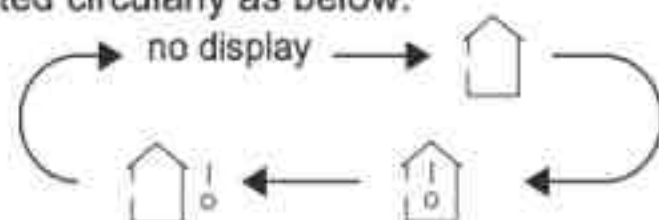

- When selecting "🏠" or no display with remote controller, temperature indicator on indoor unit displays set temperature.
- When selecting "🏠" with remote controller, temperature indicator on indoor unit displays indoor ambient temperature.
- When selecting "🏠!" with remote controller, temperature indicator on indoor unit displays outdoor ambient temperature.

### Note:

- Outdoor temperature display is not available for some models. At that time, indoor unit receives "🏠!" signal, while it displays indoor set temperature.
- Its defaulted to display set temperature when turning on the unit. There is no display in the remote controller.
- Only for the models whose indoor unit has dual-8 display.
- When selecting displaying of indoor or outdoor ambient temperature, indoor temperature indicator displays corresponding temperature and automatically turn to display set temperature after three or five seconds.

## 9. WIFI button

When WiFi function is turned on, "WiFi" icon will be displayed on the remote controller; when WiFi function is turned off, "WiFi" icon will disappear. How to turn on WiFi: Press "WiFi" button to turn on WiFi function. How to turn off WiFi: Hold "WiFi" button for 5s to turn off WiFi function. Under off status, press "MODE" and "WiFi" buttons simultaneously for 1s, WiFi

- This function is only available for some models.

## 10. LIGHT button

Press this button to turn off display light on indoor unit. "💡" icon on remote controller disappears. Press this button again to turn on display light. "💡" icon is displayed.

## 11. CLOCK button

Press this button to set clock time. "🕒" icon on remote controller will blink. Press "▲" or "▼" button within 5s to set clock time. Each pressing of "▲" or "▼" button, clock time will increase or decrease 1 minute. If hold "▲" or "▼" button, 2s later, time will change quickly. Release this button when reaching your required time. Press "CLOCK" button to confirm the time. "🕒" icon stops blinking.

### Note:

- Clock time adopts 24-hour mode.
- The interval between two operation can't exceed 5s. Otherwise, remote controller will quit setting status. Operation for TIMER ON/TIMER OFF is the same.

## 12. TIMER ON / TIMER OFF button

### ● TIMER ON button

"TIMER ON" button can set the time for timer on. After pressing this button, "🕒" icon disappears and the word "ON" on remote controller blinks. Press "▲" or "▼" button to adjust TIMER ON setting. After each pressing "▲" or "▼" button, TIMER ON setting will increase or decrease 1min. Hold "▲" or "▼" button, 2s later, the time will change quickly until reaching your required time. Press "TIMER ON" to confirm it. The word "ON" will stop blinking. "🕒" icon resumes displaying. Cancel TIMER ON: Under the condition that TIMER ON is started up, press "TIMER ON" button to cancel it.

### ● TIMER OFF button

"TIMER OFF" button can set the time for timer off. After pressing this button, "🕒" icon disappears and the word "OFF" on remote controller blinks. Press "▲" or "▼" button to adjust TIMER OFF setting. After each pressing "▲" or "▼" button, TIMER OFF setting will increase or decrease 1min. Hold "▲" or "▼" button, 2s later, the time will change quickly until reaching your required time. Press "TIMER OFF" word "OFF" will stop blinking. "🕒" icon resumes displaying. Cancel TIMER OFF. Under the condition that TIMER OFF is started up, press "TIMER OFF" button to cancel it.

**Note:**

- Under on and off status, you can set TIMER OFF or TIMER ON simultaneously.
- Before setting TIMER ON or TIMER OFF, please adjust the clock time.
- After starting up TIMER ON or TIMER OFF, set the constant circulating valid. After that, air conditioner will be turned on or turned off according to setting time. ON/OFF button has no effect on setting. If you don't need this function, please use remote controller to cancel it.

**Function introduction for combination buttons****1. Energy-saving function**

Under cooling mode, press "TEMP" and "CLOCK" buttons simultaneously to start up or turn off energy-saving function. When energy-saving function is started up, "SE" will be shown on remote controller, and air conditioner will adjust the set temperature automatically according to ex-factory setting to reach to the best energy-saving effect. Press "TEMP" and "CLOCK" buttons simultaneously again to exit energy-saving function.

**Note:**

- Under energy-saving function, fan speed is defaulted at auto speed and it can't be adjusted.
- Under energy-saving function, set temperature can't be adjusted. Press "TURBO" button and the remote controller won't send signal.
- Sleep function and energy-saving function can't operate at the same time. If energy-saving function has been set under cooling mode, press sleep button will cancel energy-saving function. If sleep function has been set under cooling mode, start up the energy-saving function will cancel sleep function.

**2. 8℃ heating function**

Under heating mode, press "TEMP" and "CLOCK" buttons simultaneously to start up or turn off 8℃ heating function. When this function is started up, "8℃" and "8℃" will be shown on remote controller, and the air conditioner keep the heating status at 8℃. Press "TEMP" and "CLOCK" buttons simultaneously again to exit 8℃ heating function.

**Note:**

- Under 8℃ heating function, fan speed is defaulted at auto speed and it can't be adjusted.
- Under 8℃ heating function, set temperature can't be adjusted. Press "TURBO" button and the remote controller won't send signal.
- Sleep function and 8℃ heating function can't operate at the same time. If 8℃ heating function has been set under cooling mode, press sleep button will cancel 8℃ heating function. If sleep function has been set under cooling mode, start up the 8℃ heating function will cancel sleep function.
- Under °F temperature display, the remote controller will display 46 °F heating.

**3. Child lock function**

Press "▲" and "▼" simultaneously to turn on or turn off child lock function. When child lock function is on, "🔒" icon is displayed on remote controller. If you operate the remote controller, the "🔒" icon will blink three times without sending signal to the unit.

**4. Temperature display switchover function**

Under OFF status, press "▼" and "MODE" buttons simultaneously to switch temperature display between °C and °F.

**5. I FEEL Function**

Press "▲" and "MODE" buttons simultaneously to start I FEEL function and "I FEEL" will be displayed on the remote controller. After this function is set, the remote controller will send the detected ambient temperature to the controller and the unit will automatically adjust the indoor temperature according to the detected temperature. Press this two buttons simultaneously again to close I FEEL function and "I FEEL" will disappear.

- Please put the remote controller near user when this function is set. Do not put the remote controller near the object of high temperature or low temperature in order to avoid detecting inaccurate ambient temperature. When I FEEL function is turned on, the remote controller should be put within the area where indoor unit can receive the signal sent by the remote controller.

If "H1" is displayed on the remote controller while it's not operated by the professional person/after-sales person, it belongs to the misoperation.

Please operate it as below to cancel it. Under the OFF status of remote controller, hold the Mode button for 5s to cancel "H1" display.

**Note:**

- If remote controller displays "H1", it belongs to the normal function reminder. If the unit is defrosting under heating mode, it operates according to H1 defrosting mode. "H1" won't be displayed on the panel of indoor unit;
- Once you set H1 mode, if you turn off unit by remote controller, H1 will display 3 times on the remote controller and then disappear;
- Also, when you set H1 mode, when you change to heating mode, H1 will display 3 times on the remote controller and then disappear.

## Replacement of batteries in remote controller

1. Press the back side of remote controller marked with " " , as shown in the fig, and then push out the cover of battery box along the arrow direction.
2. Replace two 7# (AAA 1.5V) dry batteries, and make sure the position of "+" polar and "-" polar are correct.
3. Reinstall the cover of battery box.

### Note:

- During operation, point the remote control signal sender at the receiving window on indoor unit.
- The distance between signal sender and receiving window should be no more than 8m, and there should be no obstacles between them.
- Signal may be interfered easily in the room where there is fluorescent lamp or wireless telephone; remote controller should be close to indoor unit during operation.
- Replace new batteries of the same model when replacement is required.
- When you dont use remote controller for a long time, please take out the batteries.
- If the display on remote controller is fuzzy or theres no display, please replace batteries.

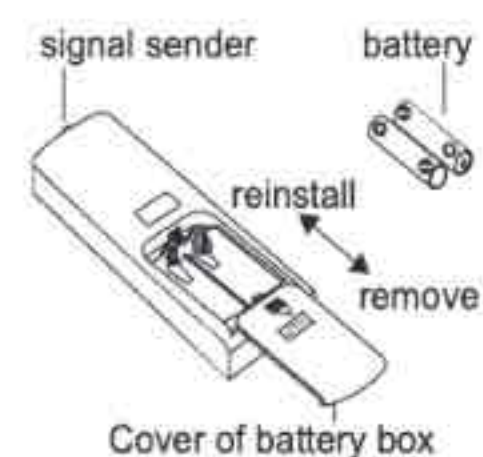



## 6.3 Brief Description of Modes and Functions

### 1. Basic function of system

#### (1) Cooling mode

- (1) Under this mode, fan and swing operates at setting status. Temperature setting range is 60.8~86.0°F.
- (2) During malfunction of outdoor unit or the unit is stopped because of protection, indoor unit keeps original operation status.

#### (2) Drying mode

- (1) Under this mode, fan operates at low speed and swing operates at setting status. Temperature setting range is 60.8~86.0°F.
- (2) During malfunction of outdoor unit or the unit is stopped because of protection, indoor unit keeps original operation status.
- (3) Protection status is same as that under cooling mode.
- (4) Sleep function is not available for drying mode.

#### (3) Heating mode

- (1) Under this mode, Temperature setting range is 60.8~86.0°F.
- (2) Working condition and process for heating mode:

When turn on the unit under heating mode, indoor unit enters into cold air prevention status. When the unit is stopped or at OFF status, and indoor unit has been started up just now, the unit enters into residual heat-blowing status.

#### (4) Working method for AUTO mode:

1. Working condition and process for AUTO mode:
  - a. Under AUTO mode, standard heating  $T_{\text{preset}}=68.0^{\circ}\text{F}$  and standard cooling  $T_{\text{preset}}=77.0^{\circ}\text{F}$ . The unit will switch mode automatically according to ambient temperature.
2. Protection function
  - a. During cooling operation, protection function is same as that under cooling mode.
  - b. During heating operation, protection function is same as that under heating mode.
3. Display: Set temperature is the set value under each condition. Ambient temperature is ( $T_{\text{amb.}}-T_{\text{compensation}}$ ) for heat pump unit and  $T_{\text{amb.}}$  for cooling only unit.
4. If there's I feel function,  $T_{\text{compensation}}$  is 0. Others are same as above.

#### (5) Fan mode

Under this mode, indoor fan operates at set fan speed. Compressor, outdoor fan, 4-way valve and electric heating tube stop operation. Indoor fan can select to operate at high, medium, low or auto fan speed. Temperature setting range is 60.8~86.0°F.

### 2. Other control

#### (1) Buzzer

Upon energization or availably operating the unit or remote controller, the buzzer will give out a beep.

#### (2) Auto button

If press this auto button when turning off the unit, the complete unit will operate at auto mode. Indoor fan operates at auto fan speed and swing function is turned on. Press this auto button at ON status to turn off the unit.

#### (3) Auto fan

Heating mode: During auto heating mode or normal heating mode, auto fan speed will adjust the fan speed automatically according to ambient temperature and set temperature.

#### (4) Sleep

After setting sleep function for a period of time, system will adjust set temperature automatically.

#### (5) Timer function:

General timer and clock timer functions are compatible by equipping remote controller with different functions.

#### (6) Memory function

memorize compensation temperature, off-peak energization value.

Memory content: mode, up&down swing, light, set temperature, set fan speed, general timer (clock timer cant be memorized).

After power recovery, the unit will be turned on automatically according to memory content.

#### (7) Health function

During operation of indoor fan, set health function by remote controller. Turn off the unit will also turn off health function.

Turn on the unit by pressing auto button, and the health is defaulted ON.

**(8) I feel control mode**

After controller received I feel control signal and ambient temperature sent by remote controller, controller will work according to the ambient temperature sent by remote controller.

**(9) Compulsory defrosting function****(1) Start up compulsory defrosting function**

Under ON status, set heating mode with remote controller and adjust the temperature to 60.8°F. Press "+, -, +, -, +,-" button successively within 5s and the complete unit will enter into compulsory defrosting status. Meanwhile, heating indicator on indoor unit will ON 10s and OFF 0.5s successively. (Note: If complete unit has malfunction or stops operation due to protection, compulsory defrosting function can be started up after malfunction or protection is resumed.)

**(2) Exit compulsory defrosting mode**

After compulsory defrosting is started up, the complete unit will exit defrosting operation according to the actual defrosting result, and the complete unit will resume normal heating operation.

**(10) Refrigerant recovery function:****(1) Enter refrigerant recycling function**

Within 5min after energizing (unit ON or OFF status is ok), continuously press LIGHT button for 3 times within 3s to enter refrigerant recycling mode; Fo is displayed and refrigerant recycling function is started. At this moment, the maintenance people closes liquid valve. After 5min, stick the thimble of maintenance valve with a tool. If there is no refrigerant spraying out, close the gas valve immediately and then turn off the unit to remove the connection pipe.

**(2) Exit refrigerant recycling function**

After entering refrigerant recycling mode, when receive any remote control signal or enter refrigerant recycling mode for 25min, the unit will exit refrigerant recycling mode automatically. If the unit is in standby mode before refrigerant recycling, it will be still in standby mode after finishing refrigerant recycling; if the unit is in ON status before refrigerant recycling, it will still run in original operation mode.

**(11) Ambient temperature display control mode**

1. When user set the remote controller to display set temperature (corresponding remote control code: 01), current set temperature will be displayed.

2. Only when remote control signal is switched to indoor ambient temperature display status (corresponding remote control code: 10) from other display status (corresponding remote control code: 00, 01, 11), controller will display indoor ambient temperature for 3s and then turn back to display set temperature.

Under this mode, indoor fan operates at set fan speed. Compressor, outdoor fan, 4-way valve and electric heating tube stop operation. Indoor fan can select to operate at high, medium, low or auto fan speed. Temperature setting range is 60.8~86.0°F.

**(12) Off-peak energization function:**

Adjust compressors minimum stop time. The original minimum stop time is 180s and then we change to:

The time interval between two start-ups of compressor can't be less than  $180+T$  s ( $0 \leq T \leq 15$ ). T is the variable of controller. That's to say the minimum stop time of compressor is 180s~195s. Read-in T into memory chip when refurbish the memory chip each time. After power recovery, compressor can only be started up after  $180+T$  s at least.

**(13) SE control mode**

The unit operates at SE status.

**(14) X-fan mode**

When X-fan function is turned on, after turn off the unit, indoor fan will still operate at low speed for 2min and then the complete unit will be turned off. When x-fan function is turned off, after turn off the unit, the complete unit will be turned off directly.

**(15) 8° heating function**

Under heating mode, you can set 8° heating function by remote controller. The system will operate at 8° set temperature.

**(16) Turbo fan control function**

Set turbo function under cooling or heating mode to enter into turbo fan speed. Press fan speed button to cancel turbo wind.

No turbo function under auto, dry or fan mode.

## Outdoor Units

### 1. Input Parameter Compensation and Calibration

#### (1) Check the ambient temperature compensation function Indoor ambient temperature compensation function.

- In cooling mode, the indoor ambient temperature participating in computing control = ( $T_{\text{indoor ambient temperature}} - \Delta T_{\text{cooling indoor ambient temperature compensation}}$ )
- In heating mode, the indoor ambient temperature participating in computing control = ( $T_{\text{indoor ambient temperature}} - \Delta T_{\text{heating indoor ambient temperature compensation}}$ )

#### (2) Check effective judgment controls of parameters

Effective judgment function of the outdoor exhaust temperature thermo-bulb When conditions a and b are satisfied, the outdoor exhaust temperature thermo-bulb is judged not to be connected into place, the mainboard of outer units will display failure of the outdoor exhaust temperature thermo-bulb (not connected into place), stop the machine for repairing, and resume the machine by remote controls of ON/OFF.

##### a. Judgment of exhaust detection temperature change:

After the compressor starts up and runs for 10 minutes, if the compressor frequency  $f \geq 40\text{Hz}$ , and the rising value  $T_{\text{exhaust}}$  ( $T_{\text{exhaust (after start-up for 10 minutes)}} - T_{\text{exhaust (before start-up)}}$ )  $< 35.6^\circ\text{F}$ , the outdoor exhaust temperature thermo-bulb can be judged not to be connected into place (judging once when the power is on the first time).

b. Comparative judgment of exhaust detection temperature and condenser detection temperature ( $T_{\text{pipe temperature}} = T_{\text{outdoor pipe temperature in cooling mode}}$ ,  $T_{\text{pipe temperature}} = T_{\text{indoor pipe temperature in heating mode}}$ ): After the compressor starts up and runs for 10 minutes, if the compressor frequency  $f \geq 40\text{Hz}$ , and  $T_{\text{pipe temperature}} \geq (T_{\text{exhaust}} + 37.4)$ , the outdoor exhaust temperature thermobulb can be judged not to be connected into place (judging once when power is on the first time).

### 2. Basic Functions

#### (1) Cooling Mode

##### 1. Conditions and processes of cooling operation:

- If the compressor is shut down, and  $[T_{\text{setup}} - (T_{\text{indoor ambient temperature}} - \Delta T_{\text{cooling indoor ambient temperature compensation}})] \leq 32.9^\circ\text{F}$ , start up the machine for cooling, the cooling operation will start;
- During operations of cooling, if  $32^\circ\text{F} \leq [T_{\text{setup}} - (T_{\text{indoor ambient temperature}} - \Delta T_{\text{cooling indoor ambient temperature compensation}})] < 35.6^\circ\text{F}$ , the cooling operation will be still running;
- During operations of cooling, if  $35.6^\circ\text{F} \leq [T_{\text{setup}} - (T_{\text{indoor ambient temperature}} - \Delta T_{\text{cooling indoor ambient temperature compensation}})]$ , the cooling operation will stop after reaching the temperature point.

##### 2. Temperature setting range

- If  $T_{\text{outdoor ambient temperature}} \geq [T_{\text{low-temperature cooling temperature}}]$ , the temperature can be set at:  $60.8\sim 86^\circ\text{F}$  (Cooling at room temperature);
- If  $T_{\text{outdoor ambient temperature}} < [T_{\text{low-temperature cooling temperature}}]$ , the temperature can be set at:  $77\sim 86^\circ\text{F}$  (Cooling at low temperature), that is, the minimum setting temperature for outer units judgment is  $77^\circ\text{F}$ .

#### (2) Dehumidifying Mode

- Conditions and processes of dehumidifying operations: Same as the cooling mode;
- The temperature setting range is:  $60.8\sim 86^\circ\text{F}$ ;

#### (3) Air-supplying Mode

- The compressor, outdoor fans and four-way valves are switched off;
- The temperature setting range is:  $60.8\sim 86^\circ\text{F}$ .

#### (4) Heating Mode

1. Conditions and processes of heating operations: ( $T_{\text{indoor ambient temperature}}$  is the actual detection temperature of indoor environment thermo-bulb,  $T_{\text{heating indoor ambient temperature compensation}}$  is the indoor ambient temperature compensation during heating operations)

- If the compressor is shut down, and  $[(T_{\text{indoor ambient temperature}} - \Delta T_{\text{heating indoor ambient temperature compensation}}) - T_{\text{setup}}] \leq 32.9^\circ\text{F}$ , start the machine to enter into heating operations for heating;
  - During operations of heating, if  $32^\circ\text{F} \leq [(T_{\text{indoor ambient temperature}} - \Delta T_{\text{heating indoor ambient temperature compensation}}) - T_{\text{setup}}] < 35.6^\circ\text{F}$ , the heating operation will be still running;
  - During operations of heating, if  $35.6^\circ\text{F} \leq [(T_{\text{indoor ambient temperature}} - \Delta T_{\text{heating indoor ambient temperature compensation}}) - T_{\text{setup}}]$ , the heating operation will stop after reaching the temperature point.
2. The temperature setting range in this mode is:  $60.8\sim 86^\circ\text{F}$ .

### 3. Special Functions

#### Defrosting Control

##### ① Conditions for starting defrosting

After the time for defrosting is judged to be satisfied, if the temperature for defrosting is satisfied after detections for continuous 3minutes, the defrosting operation will start.

##### ② Conditions of finishing defrosting

The defrosting operation can exit when any of the conditions below is satisfied:

##### ③ $T_{\text{outdoor pipe temperature}} \geq (T_{\text{outdoor ambient temperature}} - [T_{\text{temperature 1 of finishing defrosting}}])$ ;

##### ④ The continuous running time of defrosting reaches [tmax. defrosting time].

### 4. Control Logic

#### (1) Compressor Control

Start the compressor after starting cooling, heating, dehumidifying operations, and the outer fans start for 5s; When the machine is shutdown, in safety stops and when switching to air-supplying mode, the compressor will stop immediately. In all modes: once the compressor starts up, it will not be allowed to stop until having run for the [tmin. compressor running time] (Note: including cases of shutdown when the temperature point is reached; except the cases requiring stopping the compressor such as fault protection, remote shutdown, mode switching etc.); In all modes: once the compressor stops, it will be allowed be restart after 3-minute delay (Note: The indoor units have a function of power memory, the machine can be restarted after remote shutdown and powering up again without delay).

##### 1. Cooling mode

Start the machine to enter into cooling operation for cooling, the compressor is switched on.

##### 2. Dehumidifying mode

Same as the cooling mode.

##### 3. Air-supplying mode

The compressor is switched off.

##### 4. Heating mode

(1) Start the machine to enter into heating operation for heating, the compressor is switched on.

(2) Defrosting:

a. Defrosting starts: the compressor is shut down, and restarts it after 55-second delay.

b. Defrosting ends: the compressor stops, then starts it after 55-second delay.

#### (2) Outer Fans Control

Notes:

Only the outer fans run for at least 80s in each air flow speed can the air flow be switched;

After the outer fans run compulsively in high speed for 80s when the machine starts up, control the air flow according to the logic.

After remote shutdown, safety stops, and when the machine stops after reaching the temperature point, as well as after the compressor stops, extend 1 minute, the outer fans will stop (During the period in the 1 minute, the air flow of outer fans can be changed according to the outdoor ambient temperature changes); When running with force, the outdoor fans shall run in the highest air flow.

#### (3) 4-way valve control

1. The 4-way valve control under the modes of Cooling, dehumidification and supplying air: closing;

2. The status of 4-way valve control under the heating mode: getting power;

(1) 4-way valve power control under heating mode

a. Starts the machine under heating mode, the 4-way valve will get power immediately.

(2) 4-way valve power turn-off control under heating mode

a. When you should turn off the power or switch to other mode under heating mode, the power of 4-way valve will be cut after 2 minutes of the compressor stopped.

b. When all kinds of protection stops, the power of 4-way valve will be cut after delaying 4 minutes.

(3) Defrosting control under heating mode:

a. Defrosting begins: The power of 4-way valve will be cut after 50s of entering into the defrosting compressor.

b. Defrosting stops: The 4-way valve will get power after 50s of exiting the defrosting compressor.

#### (4) Evaporator frozen-preventing protection function

At the mode of Cooling, dehumidifying:

Evaporator frozen-preventing protection function is allowed to begin after 6 min of starting the compressor.

**1. Starting estimation:**

After the compressor stopped working for 180s, if  $T_{\text{inner pipe}} > [T_{\text{frozen-preventing frequency-limited temperature}}$  (the temperature of hysteresis is 35.6°F ), the machine is only allowed to start for operating, otherwise it should not be started, and should be stopped to treat according to the frozen-preventing protection: Clear the trouble under the mode of power turn-off / heating, and the protection times are not counted.

**2. Frequency limited**

$[T_{\text{frozen-preventing normal speed frequency-reducing temperature}}] \leq [T_{\text{inner pipe}} T_{\text{frozen-preventing frequency-limited temperature}}]$  , you should limit the frequency raising of compressor.

**3. Reducing frequency at normal speed:**

If  $[T_{\text{frozen-preventing high speed frequency-reducing temperature}}] \leq [T_{\text{inner pipe}} T_{\text{frozen-preventing normal speed frequency-reducing temperature}}]$ , you should adjust the compressor frequency by reducing 8Hz/90s till the lower limit;

**4. Reducing frequency at high speed:**

If  $[T_{\text{frozen-preventing power turn-off temperature}}] \leq T_{\text{inner pipe}} [T_{\text{frozen-preventing high speed frequency-reducing temperature}}]$  you should adjust the compressor frequency by reducing 30Hz/90s till the lower limit;

**5. Power turn-off:**

If the  $T_{\text{inner pipe}} < [T_{\text{frozen-preventing power turn-off temperature}}]$ , then frozen-preventing protect to stop the machine; If  $T_{\text{frozen-preventing frequency-limited temperature}} < T_{\text{inner pipe}}$  , and the compressor has stopped working for 3 minutes, the whole machine should be allowed to operate.

6. If the frozen-preventing protection power turn-off continuously occurs for six times, it should not be resumed automatically, and you should press the ON/OFF button to resume if the fault keeps on. During the process of running, if the running time of compressor exceeds the t evaporator frozen-preventing protection times zero clearing time , the times of frozen-preventing power turn-off should be cleared to recount. The mode of stopping the machine or transferring to supply air will clear the trouble times immediately (if the trouble can not be resumed, mode transferring will not clear it).

**(5) Overload protection function**

Overload protection function at the mode of Cooling and dehumidifying

**1. Starting estimation:**

After the compressor stopped working for 180s, if  $T_{\text{outer pipe}} < [T_{\text{Cooling overload frequency-limited temperature}}]$  (the temperature of hysteresis is 35.6°F ), the machine is allowed to start, otherwise it should not be started, and should be stopped to treat according to the overload protection: Clear the trouble at the mode of power turn-off / heating, and the protection times are not counted.

**2. Frequency limited**

If  $[T_{\text{Cooling overload frequency-limited temperature}}] \leq [T_{\text{outer pipe}} T_{\text{Cooling overload frequency reducing temperature at normal speed}}]$ , you should limit the frequency raising of compressor.

**3. Reducing frequency at normal speed and power turn-off:**

If  $[T_{\text{Cooling overload frequency reducing temperature at high speed}}] \leq T_{\text{outer pipe}} < [T_{\text{Cooling overload power turn-off temperature}}]$  , you should adjust the compressor frequency by reducing 8Hz/90s till the lower limit; After it was running 90s at the lower limit, if  $[T_{\text{Cooling overload frequency reducing temperature at normal speed}}] \leq T_{\text{outer pipe}}$ , then Cooling overload protects machine stopping;

**4. Reducing frequency at high speed and stop machine:**

If  $[T_{\text{Cooling overload frequency reducing temperature at high speed}}] \leq T_{\text{outer pipe}} [T_{\text{Cooling overload power turn-off temperature}}]$ , you should adjust the compressor frequency by reducing 30Hz/90s till the lower limit; After it was running 90s at the lower limit, if  $[T_{\text{Cooling overload frequency reducing temperature at normal speed}}] \leq [T_{\text{outer pipe}}]$ , then Cooling overload protects machine stopping;

**5. Power turn-off:**

If the  $[T_{\text{Cooling overload power turn-off temperature}}] \leq T_{\text{outer pipe}}$ , then Cooling overload protects machine stopping; If  $[T_{\text{outer pipe}}] < [T_{\text{Cooling overload frequency-limited temperature}}]$  and the compressor has been stopped working for 3 minutes, the machine should be allowed to operate.

6. If the Cooling overload protection power turn-off continuously occurs for six times, it should not be resumed automatically, and you should press the ON/OFF button to resume if the fault keeps on. During the process of running, if the running time of compressor exceeds the t overload protection times zero clearing time , the times of overload protection power turn-off should be cleared to recount. The mode of stopping the machine or transferring to supply air will clear the trouble times immediately (if the trouble can not be resumed, transferring mode will not clear it).

**Overload protection function at the mode of heating****Starting estimation :**

After the compressor stopped working for 180s, if  $T_{\text{inner pipe}} T_{\text{heating overload frequency-limited temperature}}$  (the temperature of hysteresis is 35.6°F ), the machine is allowed to start, otherwise it should not be started, and should be stopped to treat according to the overload protection:

Clear the trouble at the mode of power turn-off / heating, and the protection times are not counted.

### 1. Frequency limited

If  $[T_{\text{heating overload frequency-limited temperature}}] \leq T_{\text{inner pipe}} < [T_{\text{heating overload frequency reducing temperature at normal speed}}]$ , you should limit the frequency raising of compressor.

### 2. Reducing frequency at normal speed and stopping machine:

If  $[T_{\text{heating overload frequency reducing temperature at normal speed}}] \leq T_{\text{inner pipe}} < [T_{\text{heating overload frequency reducing temperature at high speed}}]$ , you should adjust the compressor frequency by reducing 8Hz/90s till the lower limit; After it was running 90s at the lower limit, if  $T_{\text{heating overload frequency reducing temperature at normal speed}} \leq T_{\text{inner pipe}}$ , then overload protects machine stopping;

### 3. Reducing frequency at high speed and power turn-off:

If  $[T_{\text{heating overload frequency reducing temperature at high speed}}] \leq T_{\text{inner pipe}} < [T_{\text{heating overload power turn-off temperature}}]$ , you should adjust the compressor frequency by reducing 30Hz/90s till the lower limit; After it was running 90s at the lower limit, if  $T_{\text{heating overload frequency reducing temperature at normal speed}} \leq T_{\text{outer pipe}}$ , then Cooling overload protects machine stopping;

### 4. Power turn-off:

If the  $[T_{\text{heating overload power turn-off temperature}}] \leq T_{\text{inner pipe}}$ , then overload protects machine stopping; If  $T_{\text{inner pipe}} < T_{\text{heating overload frequency-limited temperature}}$  and the compressor has been stopped working for 3 minutes, the machine should be allowed to operate.

5. If the overload protection power turn-off continuously occurs for six times, it should not be resumed automatically, and you should press the ON/OFF button to resume if the fault keeps on. During the process of running, if the running time of compressor exceeds the  $t_{\text{overload protection times zero clearing time}}$ , the times of overload protection power turn-off should be cleared to recount. The mode of stopping the machine or transferring to supply air will clear the trouble times immediately (if the trouble can not be resumed, transferring mode will not clear it). Protective function for discharge temperature of compressor

#### 1. Starting estimation:

After the compressor stopped working for 180s, if  $T_{\text{Discharge}} < T_{\text{Discharge limited temperature}}$  (the temperature of hysteresis is 35.6°F), the machine is allowed to start, otherwise it should not be started, and should be stopped to treat according to the discharge temperature:

The machine should be stopped or transferred to supply air, the trouble should be cleared immediately, and the protection times are not counted.

### 2. Frequency limited

If  $[T_{\text{Limited frequency temperature during discharging}}] \leq T_{\text{Discharge}} < [T_{\text{frequency reducing temperature at normal speed during discharging}}]$ , you should limit the frequency raising of compressor.

### 3. Reducing frequency at normal speed and stopping machine:

If  $[T_{\text{frequency reducing temperature at normal speed during discharging}}] \leq T_{\text{Discharge}} < [T_{\text{frequency reducing temperature at high speed during discharging}}]$ , you should adjust the compressor frequency by reducing 8Hz/90s till the lower limit; After it was running 90s at the lower limit, if  $[T_{\text{frequency reducing temperature at normal speed during discharging}}] \leq T_{\text{Discharge}}$ , you should discharge to protect machine stopping;

### 4. Reducing frequency at high speed and power turn-off:

If  $[T_{\text{frequency reducing temperature at high speed during discharging}}] \leq T_{\text{Discharge}} < [T_{\text{Stop temperature during discharging}}]$ , you should adjust the compressor frequency by reducing 30Hz/90s till the lower limit; After it was running 90s at the lower limit, if  $[T_{\text{frequency reducing temperature at normal speed during discharging}}] \leq T_{\text{Discharge}}$ , you should discharge to protect machine stopping;

### 5. Power turn-off:

If the  $[T_{\text{Power turn-off temperature during discharging}}] \leq T_{\text{Discharge}}$ , you should discharge to protect machine stopping; If  $[T_{\text{Discharge}}] < [T_{\text{Limited frequency temperature during discharging}}]$  and the compressor has been stopped for 3 minutes, the machine should be allowed to operate.

6. If the discharging temperature protection of compressor continuously occurs for six times, it should not be resumed automatically, and you should press the ON/OFF button to resume. During the process of running, if the running time of compressor exceeds the  $t_{\text{Protection times clearing of discharge}}$ , the discharge protection is cleared to recount. Stopped or transferred to supply air mode will clear the trouble times immediately (if the trouble can not be resumed, mode transferring also will not clear it).

### 7. Frequency limited

If  $[I_{\text{Limited frequency when overcurrent}}] \leq I_{\text{AC Electric current}} < [I_{\text{frequency reducing when overcurrent}}]$ , you should limit the frequency raising of compressor.

### 8. Reducing frequency:

If  $[I_{\text{frequency reducing when overcurrent}}] \leq [I_{\text{AC Electric current}} | \text{Power turn-off when overcurrent}]$ , you should reduce the compressor frequency till the lower limit or exit the frequency reducing condition;

### 9. Power turn-off:

If  $[I_{\text{Power turn-off machine when overcurrent}}] \leq [I_{\text{AC Electric current}}]$ , you should carry out the overcurrent stopping protection; If  $I_{\text{AC Electric current}} < [I_{\text{Limited frequency when overcurrent}}]$  and the compressor has been stopped for 3 minutes, the machine should be allowed to operate.

10. If the overcurrent protection continuously occurs for six times, it should not be resumed automatically, and you should press the ON/OFF button to resume. During the process of running, if the running time of compressor exceeds the  $[t_{\text{Protection times clearing of over current}}]$ , the discharge protection is cleared to recount.

**(6)Voltage sag protection**

After start the compressor, if the time of DC link Voltage sag [ $U_{\text{Sagging protection voltage}}$ ] is measured to be less than t Voltage sag protection time , the machine should be stop at once, hand on the voltage sag trouble, reboot automatically after 30 minutes.

**(7)Communication fault**

When you have not received any correct signal from the inner machine in three minutes, the machine will stop for communication fault. When you have not received any correct signal from driver IC (aim to the controller for the separating of main control IC and driver IC), and the machine will stop for communication fault. If the communication is resumed, the machine will be allowed to operate.

**(8)Module protection**

Testing the module protective signal immediately after started, once the module protective signal is measured, stop the machine with module protection immediately. If the module protection is resumed, the machine will be allowed to operate. If the module protection continuously occurs for three times, it should not be resumed automatically, and you should press the ON/OFF button to resume. If the running time of compressor exceeds the [ $t_{\text{Protection times clearing of module}}$ ] , the module protection is cleared to recount.

**(9)Module overheating protection****1. Starting estimation:**

After the compressor stopped working for 180s, if  $T_{\text{Module}} < [T_{\text{Module frequency limited temperature}}]$  (the temperature of hysteresis is 35.6°F ), the machine is allowed to start, otherwise it should not be started, and should be stopped to treat according to the module overheating protection: The machine should be stopped or transferred to supply air, the trouble should be cleared immediately, and the protection times are not counted.

**2. Frequency limited**

If  $[T_{\text{Limited frequency temperature of module}}] \leq T_{\text{Module}} < [T_{\text{frequency reducing temperature at normal speed of module}}]$  , you should limit the frequency raising of compressor.

**3. Reducing frequency at normal speed and power turn-off:**

If  $[T_{\text{frequency reducing temperature at normal speed of module}}] \leq T_{\text{Module}} < [T_{\text{frequency reducing temperature at high speed of module}}]$ , you should adjust the compressor frequency by reducing 8Hz/90s till the lower limit; After it was running 90s at the lower limit, if  $[T_{\text{frequency reducing temperature at normal speed of module}}] \leq T_{\text{Module}}$ , you should stop the machine for module overheating protection;

**4. Reducing frequency at high speed and power turn-off:**

If  $[T_{\text{frequency reducing temperature at high speed of module}}] \leq T_{\text{Module}} < [T_{\text{Power turn-off temperature of module}}]$  you should adjust the compressor frequency by reducing 30Hz/90s till the lower limit; After it was running 90s at the lower limit, if  $[T_{\text{frequency reducing temperature at normal speed of module}}] \leq T_{\text{Module}}$ , you should stop the machine for module overheating protection;

**5. Power turn-off:**

If the  $[T_{\text{Power turn-off temperature of module}}] \leq T_{\text{Module}}$ , you should stop the machine for module overheating protection; If  $T_{\text{Module}} < [T_{\text{Limited frequency temperature of module}}]$  and the compressor has been stopped for 3 minutes, the machine should be allowed to operate.

6. If protection continuously occurs for six times, it should not be resumed automatically, and you should press the ON/OFF button to resume. During the process of running, if the running time of compressor exceeds the [ $t_{\text{Protection times clearing of module}}$ ] , the discharge protection is cleared to recount. Stopped or transferred to supply air mode will clear the trouble times immediately (if the trouble can not be resumed, mode transferring also will not clear it).

**(10)Compressor overloads protection**

If you measure the compressor overload switch action in 3s, the compressor should be stopped for overloading. The machine should be allowed to operate after overload protection was measured to resume. If the overloading protection continuously occurs for three times, it should not be resumed automatically, and you should press the ON/OFF button to resume. The protection times of compressor is allowed to clear after the compressor run [ $t_{\text{Protection times clearing of compressor overloading}}$ ] 30 minutes.

**(11)Phase current overcurrent protection of compressor**

During the running process of compressor, you could measure the phase current of the compressor, and control it according to the following steps:

**1. Frequency limited**

If  $[I_{\text{Limited frequency phase current}}] \leq [I_{\text{Phase current T frequency reducing phase current}}]$  , you should limit the frequency raising of compressor.

**2. Reducing Frequency**

If  $[I_{\text{Frequency Reducing Phase Current}}] \leq I_{\text{Phase Current}} < [I_{\text{Power Turn-Off Phase Current}}]$ , the compressor shall continue to reduce frequency till the lowest frequency limit or out of the condition of reducing frequency;

**3. Power turn-off**

If  $[I_{\text{Phase Current}}] \geq [I_{\text{Power Turn-Off Phase Current}}]$ , the compressor phase current shall stop working for overcurrent protection; if  $[I_{\text{Phase Current}}] \leq [I_{\text{Frequency Reducing Phase Current}}]$ , and the compressor have stopped working for 3 min, the machine shall be allowed to operate;

4. If the overcurrent protection of compressor phase current continuously occurs for six times, it should not be resumed automatically, and you should press the ON/OFF button to resume. During the process of running, if the running time of compressor exceeds the [ $t_{\text{Clearing Time of Compressor Phase Current Times}}$ ] , the overcurrent protection is cleared to recount.

**(12) Starting-up Failure Protection for Compressor**

Stop the compressor after its starting-up fails, restart it after 20s if the fault doesn't show, and if they are all failing for the successive start 3 times, it shall be reported as Starting-up Failure, and then restart up it after 3 min. When it still not be able to operate through carry out the above process for 5 times, it is available if press ON/OFF. And the compressor should be cleared the times after it run 2 min.

**(13) Out-of-Step Protection for Compressor**

The out-of-step protection signal should be detected immediately after starting-up compressor, and once find the out-of-step protection signal, the out-of-step protection shall be stopped; if it can run for lasting power turn-off 3 min, the machine shall be allowed to operate. If it still can't run automatically when the out-of-step protection for compressor happens to stop working for 6 times in succession, it needs to press ON/OFF to operate. And if the running time is more than 10 min, the power turn-off times for out-of-step protection shall be cleared and recounted.

**(14) Voltage Abnormity Protection for DC Bus**

To detect voltage abnormity protection for dc bus after completing the pre-charge:

**1. Over-High Voltage Protection for DC Bus:**

If it found the DC bus voltage  $U_{DC} > [U_{DC}^{\text{Jiekuangchun Protection}}]$ , turn off PFC and stop the compressor at once, and it shall show the DC over-high voltage failure; it should clear out the failure when the voltage dropped to  $U_{DC} < [U_{DC}^{\text{Jiekuangchun Recovery}}]$  and the compressor stopped for 3 min.

**2. Over-Low Voltage Protection for DC Bus:**

If it found the DC bus voltage  $U_{DC} < [U_{DC}^{\text{Wantuochun Protection}}]$ , turn off PFC and stop the compressor at once, and it shall show the DC over-low voltage; and it should clear out the failure when the voltage raised to  $U_{DC} > [U_{DC}^{\text{Wantuochun Recovery}}]$  and the compressor stopped for 3 min.

**3. To detect voltage abnormity protect for DC bus when getting electricity:**

If it found the DC bus voltage  $U_{DC} > [U_{DC}^{\text{Over-High Voltage}}]$ , turn off the relay at once, and shows voltage abnormity failure for DC Bus. And the failure can't recover except to break off and get the electricity.

**(15) Abnormity Protection for Four-way Valve**

Under the model of heating operation in good condition: the compressor is detected  $[T_{\text{Inner Tube}} < (T_{\text{Inner Ring}} - T_{\text{Abnormity Temperature Difference For Four-Way Valve Reversion}})]$ , during the running, it should be regarded as four-way valve reversion abnormity. And then it can run if stop the reversion abnormity protection for four-way valve 3 min; and if it still can't run when the reversion abnormity protection for four-way valve happens to stop working for 3 times in succession, it is available if presses ON/OFF.

Attention: the protection shall be shielded during the testing mode and defrosting process, and it shall be cleared out the failure and its times immediately when turning off or delivering wind / cooling / dehumidifying mode conversed (the inverted mode don't clear out the failure when it can't recover to operate).

**(16) PFC Protection**

1. After start up the PFC, it should detect the protection signal of PFC immediately; under the condition of PFC protection, it should turn off the PFC and compressor at one time;
2. It shows the failure is cleared out if PFC Protection stopped working 3 min and recovers to run automatically;
3. If it still can't run when it occurs PFC protection for 3 times in succession, it is available if presses ON/OFF; and clear the PFC Protection times when start up PFC for 10min.

**(17) Failure Detection for Sensor**

1. Outdoor Ambient Sensor: detect the failure of sensor at all times.
2. Outdoor Tube Sensor: You should not detect the failure of outdoor tube sensor within 10 minutes heating operation compressor except the defrosting, and you could detect it at other time.
3. Outdoor Exhaust Sensor:
  - (a) The compressor only detect the sensor failure after it start up 3 min in normal mode;
  - (b) It should detect the exhaust sensor failure immediately in the testing mode.
4. Module Temperature Sensor:
  - (a) Short-Circuit Detection: the compressor should be detected immediately when the module temperature sensor occurs short-circuits;
  - (b) Open-Circuit Detection: the compressor should be detected on open-circuit when it runs 3min (it needn't 30s avoiding the module over-heated).
  - (c) Detect the sensor failure at all times in the testing mode.
5. Disposal for Sensor Protection
  - (1) When the short-circuit of sensor is detected within 30s, It is regarded as the temperature of sensor over-high (or infinitely high), and now according to the over-high sensor, the machine should carry out the corresponding protection to stop working, and show the corresponding temperature shutdown protection and sensor failure at the same time (for example: the compressor stops immediately when the outdoor tube sensor short-circuit, and the machine shall show the overload protection and outdoor tube sensor failure).
  - (2) When the open-circuit of sensor is detected within 30s, The protection shall be stopped and it shall show the corresponding sensor failure.

#### 6. Electric Heating Function of Chassis

- (1) When  $T_{\text{outdoor amb.}} \leq 32^{\circ}\text{F}$ , the electric heating of chassis will operate;
- (2) When  $T_{\text{outdoor amb.}} > 35.6^{\circ}\text{F}$ , the electric heating of chassis will stop operation;
- (3) When  $32^{\circ}\text{F} < T_{\text{outdoor amb.}} \leq 35.6^{\circ}\text{F}$ , the electric heating of chassis will keep original status.

#### 7. Electric Heating Function of Compressor

- (1) When  $T_{\text{outdoor amb.}} \leq 23^{\circ}\text{F}$ , compressor stops operation, while the electric heating of compressor starts operation;
- (2) When  $T_{\text{outdoor amb.}} > 28.4^{\circ}\text{F}$ , the electric heating of compressor stops operation;
- (3) When  $23^{\circ}\text{F} < T_{\text{outdoor amb.}} \leq 28.4^{\circ}\text{F}$ , the electric heating of compressor will keep original status.

# Part II : Installation and Maintenance

## 7. Notes for Installation and Maintenance

### Safety Precautions: Important!

Please read the safety precautions carefully before installation and maintenance.

The following contents are very important for installation and maintenance.

Please follow the instructions below.

- The installation or maintenance must accord with the instructions.
- Comply with all national electrical codes and local electrical codes.
- Pay attention to the warnings and cautions in this manual.
- All installation and maintenance shall be performed by distributor or qualified person.
- All electric work must be performed by a licensed technician according to local regulations and the instructions given in this manual.
- Be caution during installation and maintenance. Prohibit incorrect operation to prevent electric shock, casualty and other accidents.



## Warnings

### Electrical Safety Precautions:

1. Cut off the power supply of air conditioner before checking and maintenance.
2. The air condition must apply specialized circuit and prohibit share the same circuit with other appliances.
3. The air conditioner should be installed in suitable location and ensure the power plug is touchable.
4. Make sure each wiring terminal is connected firmly during installation and maintenance.
5. Have the unit adequately grounded. The grounding wire cant be used for other purposes.
6. Must apply protective accessories such as protective boards, cable-cross loop and wire clip.
7. The live wire, neutral wire and grounding wire of power supply must be corresponding to the live wire, neutral wire and grounding wire of the air conditioner.
8. The power cord and power connection wires cant be pressed by hard objects.
9. If power cord or connection wire is broken, it must be replaced by a qualified person.
10. If the power cord or connection wire is not long enough, please get the specialized power cord or

connection wire from the manufacture or distributor. Prohibit prolong the wire by yourself.

11. For the air conditioner without plug, an air switch must be installed in the circuit. The air switch should be all-pole parting and the contact parting distance should be more than 1/8 inch.

12. Make sure all wires and pipes are connected properly and the valves are opened before energizing.

13. Check if there is electric leakage on the unit body. If yes, please eliminate the electric leakage.

14. Replace the fuse with a new one of the same specification if it is burnt down; dont replace it with a cooper wire or conducting wire.

15. If the unit is to be installed in a humid place, the circuit breaker must be installed.

### Installation Safety Precautions:

1. Select the installation location according to the requirement of this manual.(See the requirements in installation part)
2. Handle unit transportation with care; the unit should not be carried by only one person if it is more than 44.09lb.
3. When installing the indoor unit and outdoor unit, a sufficient fixing bolt must be installed; make sure the installation support is firm.
4. Ware safety belt if the height of working is above 78 3/4 inch.
5. Use equipped components or appointed components during installation.
6. Make sure no foreign objects are left in the unit after finishing installation.

### Refrigerant Safety Precautions:

When refrigerant leaks or requires discharge during installation, maintenance, or disassembly, it should be handled by certified professionals or otherwise in compliance with local laws and regulations.

1. Avoid contact between refrigerant and fire as it generates poisonous gas; Prohibit prolong the connection pipe by welding.
2. Apply specified refrigerant only. Never have it mixed with any other refrigerant. Never have air remain in the refrigerant line as it may lead to rupture or other hazards.
3. Make sure no refrigerant gas is leaking out when installation is completed.
4. If there is refrigerant leakage, please take sufficient measure to minimize the density of refrigerant.
5. Never touch the refrigerant piping or compressor without wearing glove to avoid scald or frostbite.

Improper installation may lead to fire hazard, explosion, electric shock or injury.

## Safety Precautions for Installing and Relocating the Unit:

To ensure safety, please be mindful of the following precautions.



### Warnings

**1. When installing or relocating the unit, be sure to keep the refrigerant circuit free from air or substances other than the specified refrigerant.**

Any presence of air or other foreign substance in the refrigerant circuit will cause system pressure rise or compressor rupture, resulting in injury.

**2. When installing or moving this unit, do not charge the refrigerant which is not comply with that on the nameplate or unqualified refrigerant.**

Otherwise, it may cause abnormal operation, wrong action, mechanical malfunction or even series safety accident.

**3. When refrigerant needs to be recovered during relocating or repairing the unit, be sure that the unit is running in cooling mode. Then, fully close the valve at high pressure side (liquid valve). About 30-40 seconds later, fully close the valve at low pressure side (gas valve), immediately stop the unit and disconnect power. Please note that the time for refrigerant recovery should not exceed 1 minute.**

If refrigerant recovery takes too much time, air may be sucked in and cause pressure rise or compressor rupture, resulting in injury.

**4. During refrigerant recovery, make sure that liquid valve and gas valve are fully closed and power is disconnected before detaching the connection pipe.**

If compressor starts running when stop valve is open and connection pipe is not yet connected, air will be sucked in and cause pressure rise or compressor rupture, resulting in injury.

**5. When installing the unit, make sure that connection pipe is securely connected before the compressor starts running.**

If compressor starts running when stop valve is open and connection pipe is not yet connected, air will be sucked in and cause pressure rise or compressor rupture, resulting in injury.

**6. Prohibit installing the unit at the place where there may be leaked corrosive gas or flammable gas.**

If there leaked gas around the unit, it may cause explosion and other accidents.

**7. Do not use extension cords for electrical connections. If the electric wire is not long enough, please contact a local service center authorized and ask for a proper electric wire.**

Poor connections may lead to electric shock or fire.

**8. Use the specified types of wires for electrical connections between the indoor and outdoor units. Firmly clamp the wires so that their terminals receive no external stresses.**

Electric wires with insufficient capacity, wrong wire connections and insecure wire terminals may cause electric shock or fire.

## Main Tools for Installation and Maintenance

|   |  |  |
|---|--|--|
| <p>1. Level meter, measuring tape</p>    | <p>2. Screw driver</p>                   | <p>3. Impact drill, drill head, electric drill</p>                |
| <p>4. Electroprobe</p>                   | <p>5. Universal meter</p>                | <p>6. Torque wrench, open-end wrench, inner hexagon spanner</p>  |
| <p>7. Electronic leakage detector</p>  | <p>8. Vacuum pump</p>                  | <p>9. Pressure meter</p>                                        |
| <p>10. Pipe pliers, pipe cutter</p>    | <p>11. Pipe expander, pipe bender</p>  | <p>12. Soldering appliance, refrigerant container</p>           |

# 8. Installation

## 8.1 Installation Dimension Diagram

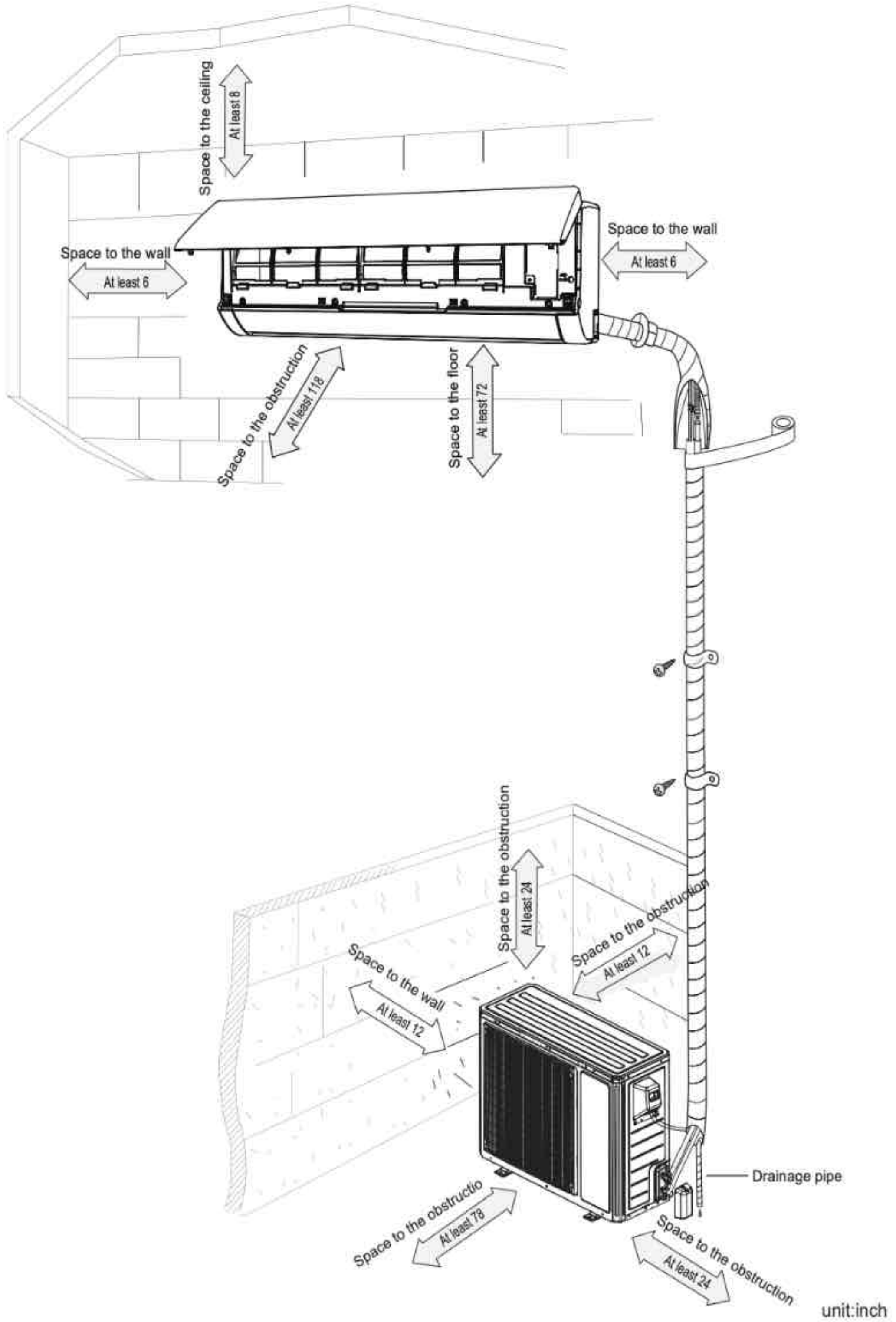

## Installation procedures

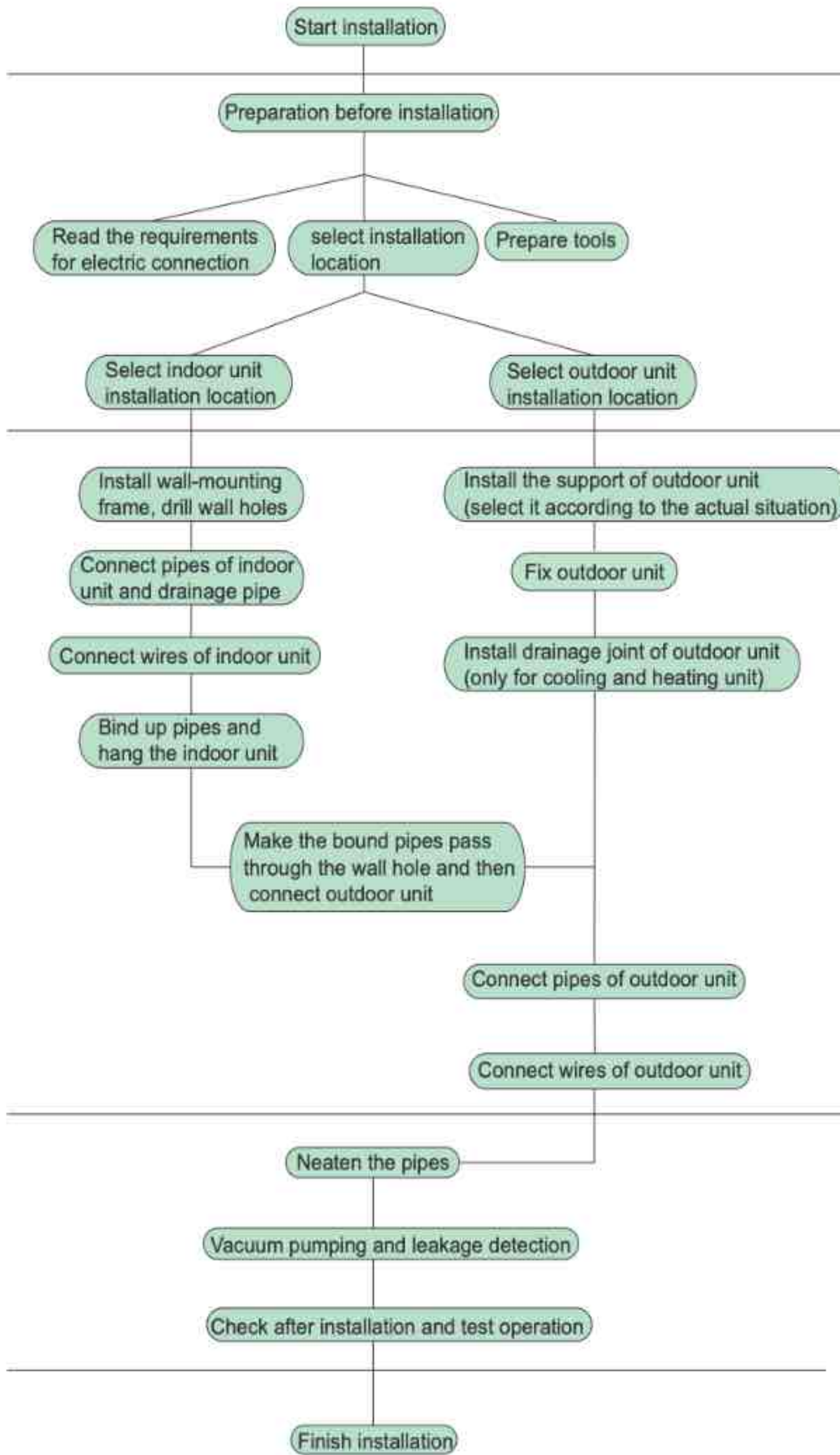

Note: this flow is only for reference; please find the more detailed installation steps in this section.

## 8.2 Installation Parts-checking

| No. | Name                         | No. | Name                                    |
|-----|------------------------------|-----|---|
| 1   | Indoor unit                  | 8   | Sealing gum                             |
| 2   | Outdoor unit                 | 9   | Wrapping tape                           |
| 3   | Connection pipe              | 10  | Support of outdoor unit                 |
| 4   | Drainage pipe                | 11  | Fixing screw                            |
| 5   | Wall-mounting frame          | 12  | Drainage plug(cooling and heating unit) |
| 6   | Connecting cable(power cord) | 13  | Owners manual, remote controller        |
| 7   | Wall pipe                    |     |   |

### ⚠ Note:

1. Please contact the local agent for installation.
2. Don't use unqualified power cord.

## 8.3 Selection of Installation Location

### 1. Basic Requirement:

Installing the unit in the following places may cause malfunction. If it is unavoidable, please consult the local dealer:

- (1) The place with strong heat sources, vapors, flammable or explosive gas, or volatile objects spread in the air.
- (2) The place with high-frequency devices (such as welding machine, medical equipment).
- (3) The place near coast area.
- (4) The place with oil or fumes in the air.
- (5) The place with sulfureted gas.
- (6) Other places with special circumstances.
- (7) The appliance shall not be installed in the laundry.
- (8) It's not allowed to be installed on the unstable or motive base structure (such as truck) or in the corrosive will not affect neighborhood.

### 2. Indoor Unit:

- (1) There should be no obstruction near air inlet and air outlet.
- (2) Select a location where the condensation water can be dispersed easily and won't affect other people.
- (3) Select a location which is convenient to connect the outdoor unit and near the power socket.
- (4) Select a location which is out of reach for children.
- (5) The location should be able to withstand the weight of indoor unit and won't increase noise and vibration.
- (6) The appliance must be installed 72inch above floor.
- (7) Don't install the indoor unit right above the electric appliance.
- (8) Please try your best to keep way from fluorescent lamp.

### 3. Outdoor Unit:

- (1) Select a location where the noise and outflow air emitted by the outdoor unit will not affect neighborhood.
- (2) The location should be well ventilated and away from strong wind.
- (3) The location should be able to withstand the weight of outdoor unit.
- (4) Make sure that the installation follows the requirement of installation dimension diagram.
- (5) Select a location which is out of reach for children and far away from animals or plants. If it is unavoidable, please add fence for safety purpose.

## 8.4 Requirements for Electric Connection

### 1. Safety Precaution

- (1) Must follow the electric safety regulations when installing the unit.
- (2) According to the local safety regulations, use qualified power supply circuit and air switch.
- (3) Make sure the power supply matches with the requirement of air conditioner. Unstable power supply or incorrect wiring may result in electric shock, fire hazard or malfunction. Please install proper power supply cables before using the air conditioner.
- (4) Properly connect the live wire, neutral wire and grounding wire of power socket.
- (5) Be sure to cut off the power supply before proceeding any work related to electricity and safety.
- (6) Do not put through the power before finishing installation.
- (7) If the supply cord is damaged, it must be replaced by the manufacturer, its service agent or similarly qualified persons in order to avoid a hazard.
- (8) The temperature of refrigerant circuit will be high, please keep the interconnection cable away from the copper tube.
- (9) The appliance shall be installed in accordance with national wiring regulations.
- (10) Installation must be performed in accordance with the requirement of NEC and CEC by authorized personnel only.

### 2. Grounding Requirement:

- (1) The air conditioner is first class electric appliance. It must be properly grounding with specialized grounding device by a professional. Please make sure it is always grounded effectively, otherwise it may cause electric shock.
- (2) The yellow-green wire in air conditioner is grounding wire, which can't be used for other purposes.
- (3) The grounding resistance should comply with national electric safety regulations.
- (4) The appliance must be positioned so that the plug is accessible.
- (5) An all-pole disconnection switch having a contact separation of at least 1/8 inch in all poles should be connected in fixed wiring.

| Air-conditioner | Air switch capacity |
|-----------------|---------------------|
| 18K             | 25A                 |

## 8.5 Installation of Indoor Unit

### 1. Choosing Installation location

Recommend the installation location to the client and then confirm it with the client.

### 2. Install Wall-mounting Frame

- (1) Hang the wall-mounting frame on the wall; adjust it in horizontal position with the level meter and then point out the screw fixing holes on the wall.
- (2) Drill the screw fixing holes on the wall with impact drill (the specification of drill head should be the same as the plastic expansion particle) and then fill the plastic expansion particles.

in the holes.

(3) Fix the wall-mounting frame on the wall with tapping screws and then check if the frame is firmly installed by pulling the frame. If the plastic expansion particle is loose, please drill another fixing hole nearby.

### 3. Install Wall-mounting Frame

(1) Choose the position of piping hole according to the direction of outlet pipe. The position of piping hole should be a little lower than the wall-mounted frame.(As show in Fig.1)

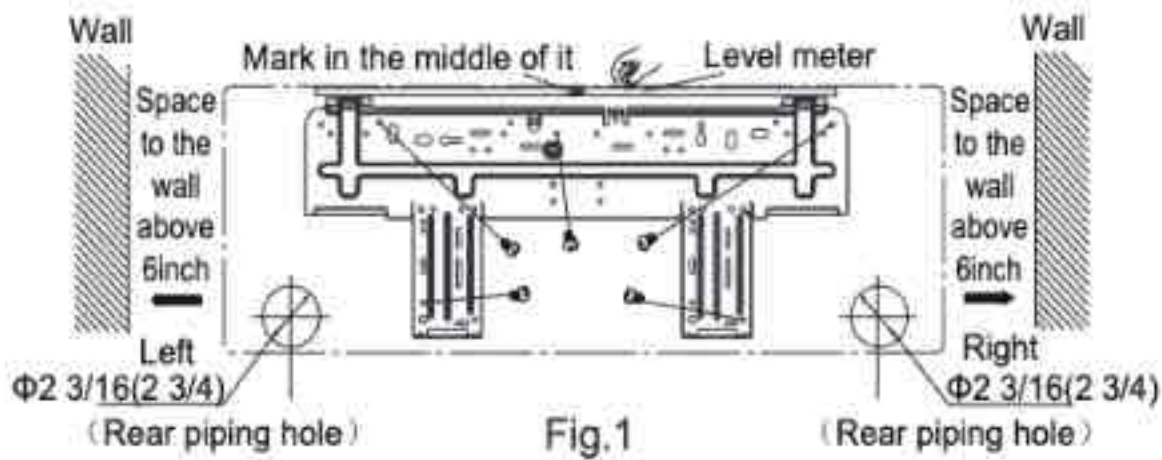

(2) Open a piping hole with the diameter of Φ2 3/16(Φ2 3/4) inch on the selected outlet pipe position. In order to drain smoothly, slant the piping hole on the wall slightly downward to the outdoor side with the gradient of 5-10°. (As show in Fig.2)

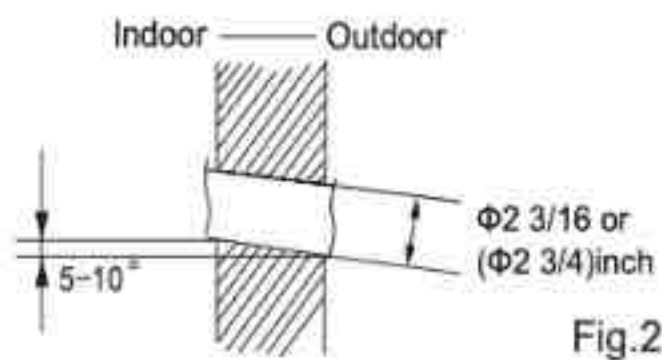

#### ⚠ Note:

Pay attention to dust prevention and take relevant safety measures when opening the hole.

### 4. Outlet Pipe

(1) The pipe can be led out in the direction of right, rear right, left or rear left.(As show in Fig.3)

(2) When selecting leading out the pipe from left or right, please cut off the corresponding hole on the bottom case.(As show in Fig.4)

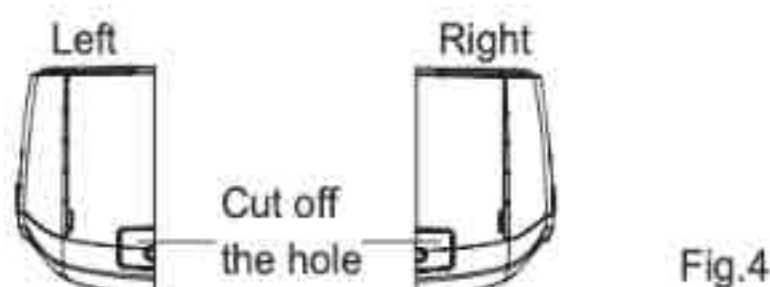
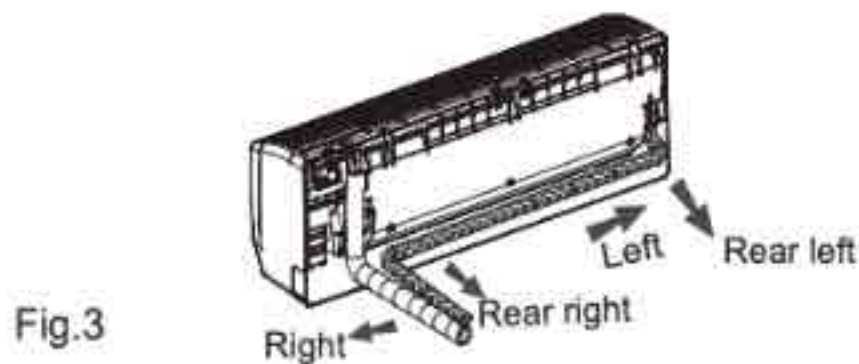

### 5. Connect the Pipe of Indoor Unit

(1) Aim the pipe joint at the corresponding bellmouth.(As show in Fig.5)

(2) Pretightening the union nut with hand.

(3) Adjust the torque force by referring to the following sheet. Place the open-end wrench on the pipe joint and place the torque wrench on the union nut. Tighten the union nut with torque wrench.(As show in Fig.6)

(4) Wrap the indoor pipe and joint of connection pipe with insulating pipe, and then wrap it with tape.(As show in Fig.7)

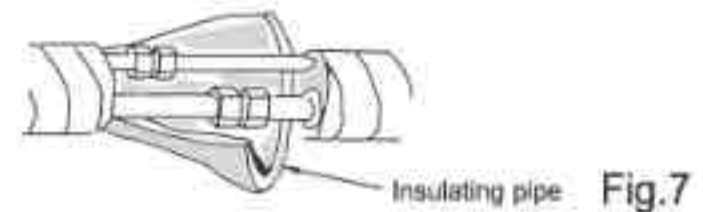
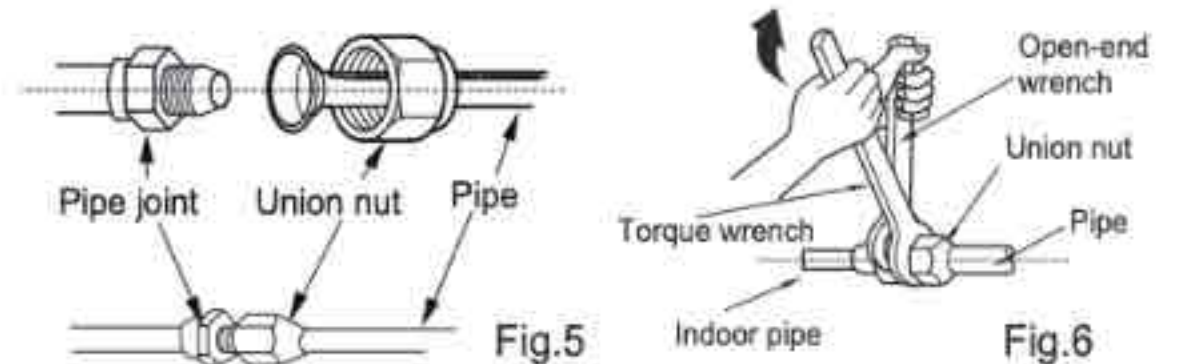

Refer to the following table for wrench moment of force:

| Hex nut diameter(inch) | Tightening torque(ft-lbf) |
|------------------------|---------------------------|
| Φ1/4                   | 11.10~14.75               |
| Φ3/8                   | 22.12~29.50               |
| Φ1/2                   | 33.19~40.56               |
| Φ5/8                   | 44.24~47.94               |
| Φ3/4                   | 51.32~55.31               |

### 6. Install Drain Hose

(1) Connect the drain hose to the outlet pipe of indoor unit.(As show in Fig.8)

(2) Bind the joint with tape.(As show in Fig.9)

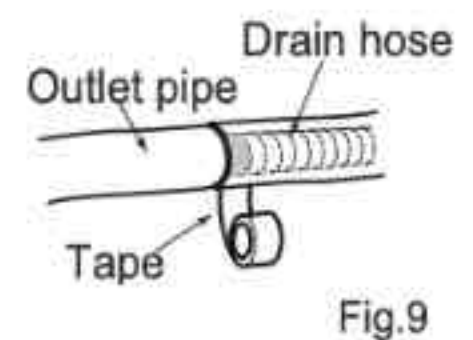
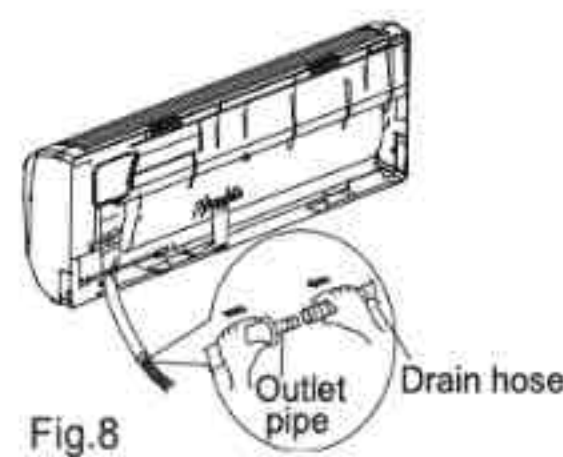

#### ⚠ Note:

(1) Add insulating pipe in the indoor drain hose in order to prevent condensation.

(2) The plastic expansion particles are not provided. (As show in Fig.10)

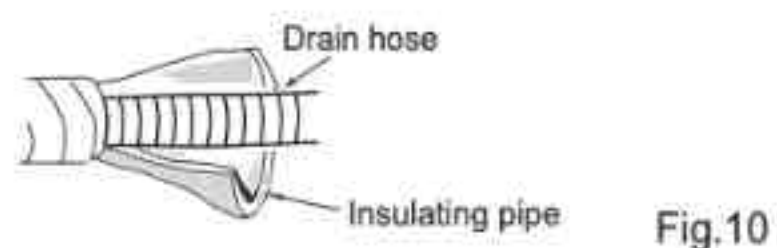

### 7. Connect Wire of Indoor Unit

(1) Open the panel, remove the screw on the wiring cover and then take down the cover.(As show in Fig.11)

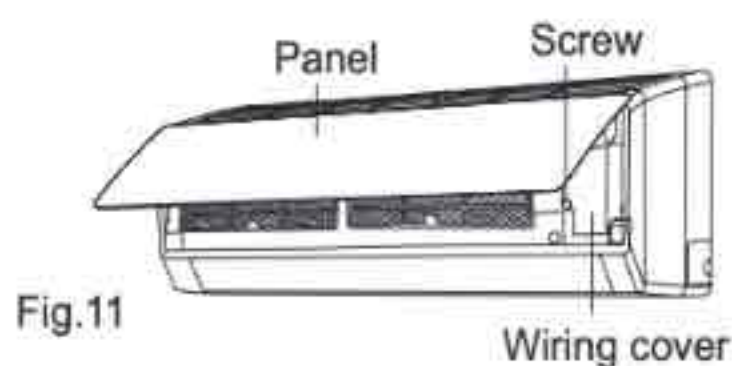

(2) Fix the wire crossing board on connection wire sleeve at the bottom case; let the connection wire sleeve go through the wire crossing hole at the back of indoor unit, and then pull it out from the front.(As show in Fig.12)

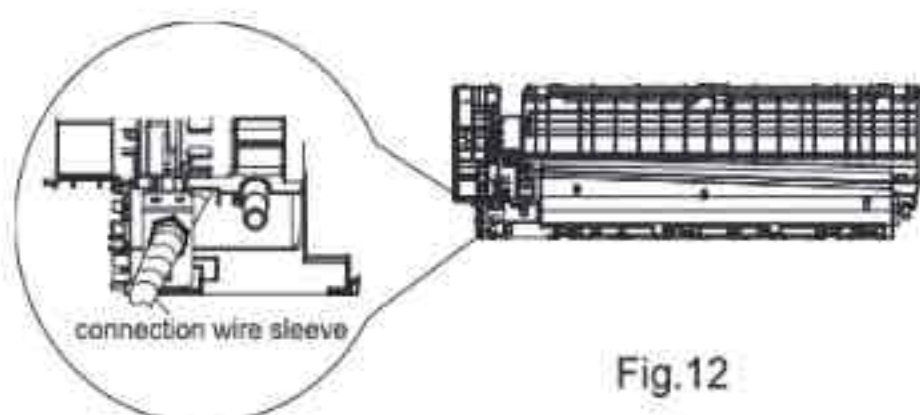

(3) Remove the wire clip; connect the power connection wire to the wiring terminal; tighten the screw and then fix the power connection wire with wire clip.(As show in Fig.13)

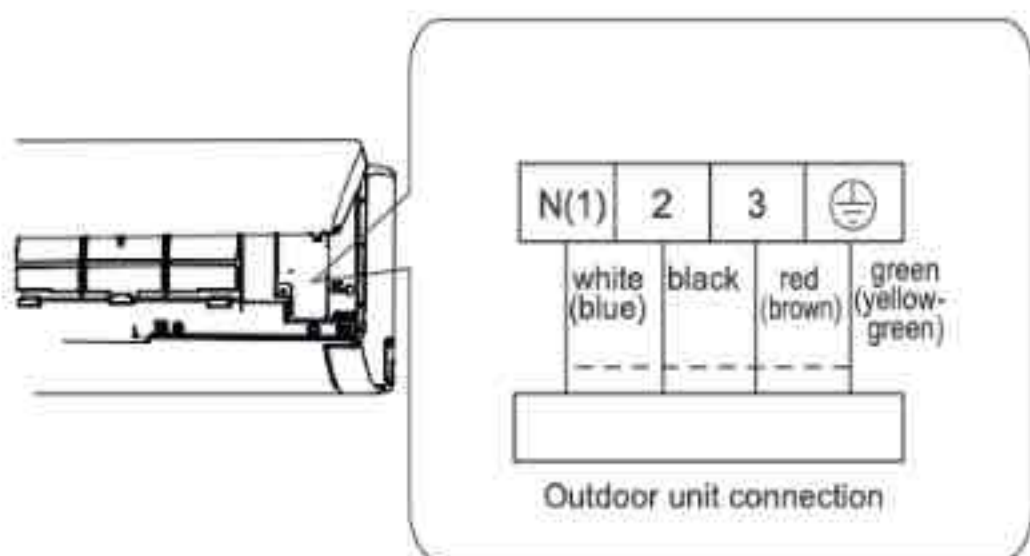

Note: the wiring board is for reference only, please refer to the actual one.

Fig.13

(4) Put wiring cover back and then tighten the screw.  
(5) Close the panel.

#### ⚠ Note:

- (1) All wires of indoor unit and outdoor unit should be connected by a professional.
- (2) If the length of power connection wire is insufficient, please contact the supplier for a new one. Avoid extending the wire by yourself.
- (3) For the air conditioner with plug, the plug should be reachable after finishing installation.
- (4) For the air conditioner without plug, an air switch must be installed in the line. The air switch should be all-pole parting and the contact parting distance should be more than 3mm.

### 8. Bind up Pipe

- (1) Bind up the connection pipe, power cord and drain hose with the band.(As show in Fig.14)
- (2) Reserve a certain length of drain hose and power cord for installation when binding them. When binding to a certain degree, separate the indoor power and then separate the drain hose.(As show in Fig.15)
- (3) Bind them evenly.
- (4) The liquid pipe and gas pipe should be bound separately at the end.

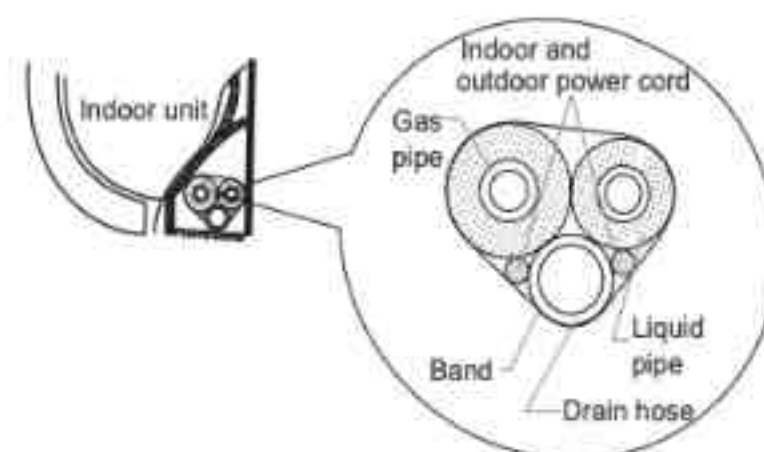

Fig.14

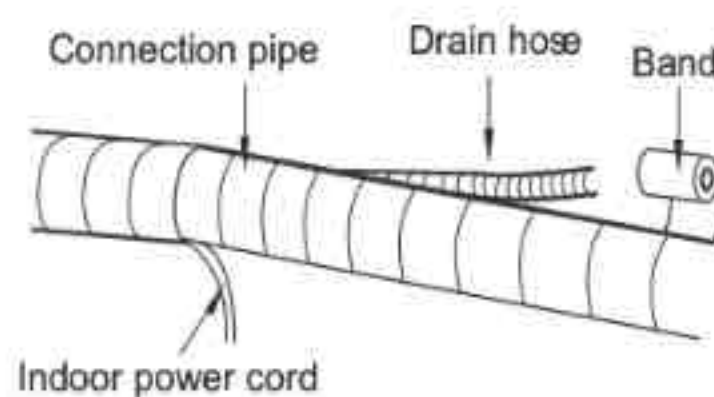

Fig.15

#### ⚠ Note:

- (1) The power cord and control wire cant be crossed or winding.
- (2) The drain hose should be bound at the bottom.

### 9. Hang the Indoor Unit

- (1) Put the bound pipes in the wall pipe and then make them pass through the wall hole.
- (2) Hang the indoor unit on the wall-mounting frame.
- (3) Stuff the gap between pipes and wall hole with sealing gum.
- (4) Fix the wall pipe.(As show in Fig.16)
- (5) Check if the indoor unit is installed firmly and closed to the wall.(As show in Fig.17)

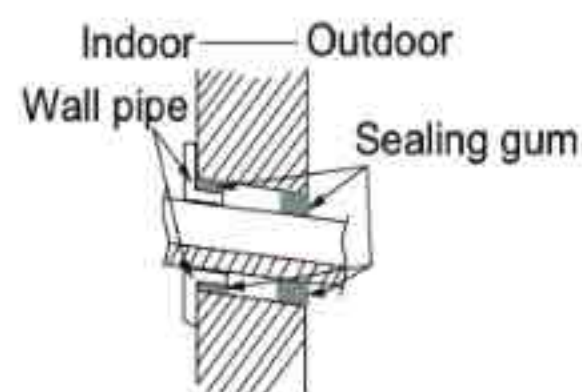
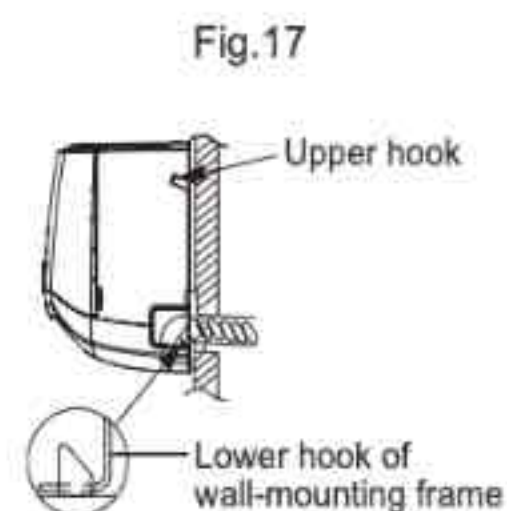

Fig.16



#### ⚠ Note:

Do not bend the drain hose too excessively in order to prevent blocking.

## 8.6 Installation of Outdoor Unit

### 1. Fix the Support of Outdoor Unit(Select it according to the actual installation situation)

- (1) Select installation location according to the house structure.
- (2) Fix the support of outdoor unit on the selected location with expansion screws.

**⚠ Note:**

- (1) Take sufficient protective measures when installing the outdoor unit.
- (2) Make sure the support can withstand at least four times the unit weight.
- (3) The outdoor unit should be installed at least 1 3/16 inch above the floor in order to install drain joint.(As show in Fig.18)
- (4) For the unit with cooling capacity of 2300W~5000W, 6 expansion screws are needed; for the unit with cooling capacity of 6000W~8000W, 8 expansion screws are needed; for the unit with cooling capacity of 10000W~16000W, 10 expansion screws are needed.

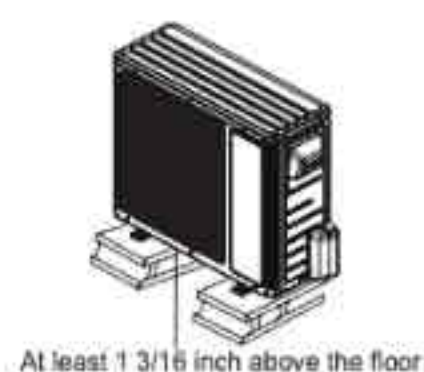

Fig.18

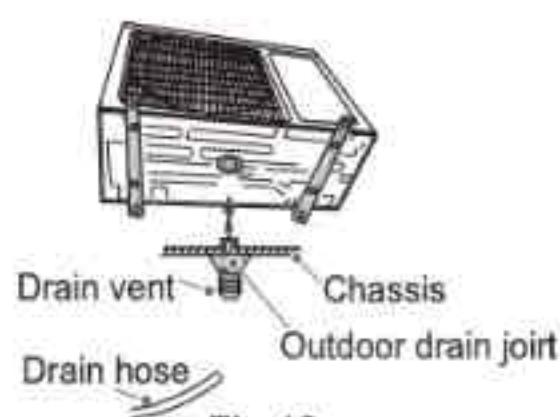

Fig.19

### 2. Install Drain Joint(only for cooling and heating unit)

- (1) Connect the outdoor drain joint into the hole on the chassis.
  - (2) Connect the drain hose into the drain vent.
- (As show in Fig.19)

### 3. Fix Outdoor Unit

- (1) Place the outdoor unit on the support.
  - (2) Fix the foot holes of outdoor unit with bolts.
- (As show in Fig.20)

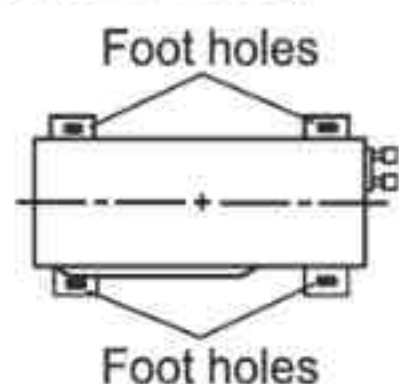

Fig.20

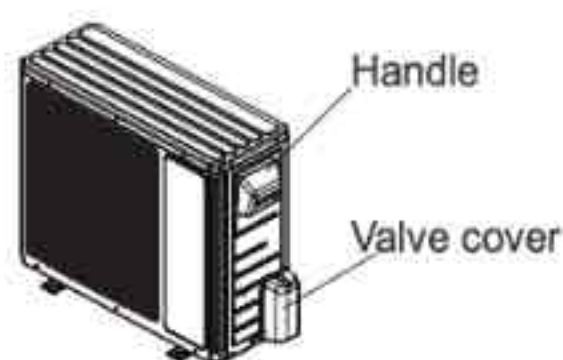

Fig.21

### 4. Connect Indoor and Outdoor Pipes

- (1) Remove the screw on the right handle and valve cover of outdoor unit and then remove the handle and valve cover.(As show in Fig.21)
- (2) Remove the screw cap of valve and aim the pipe joint at the bellmouth of pipe.(As show in Fig.22)

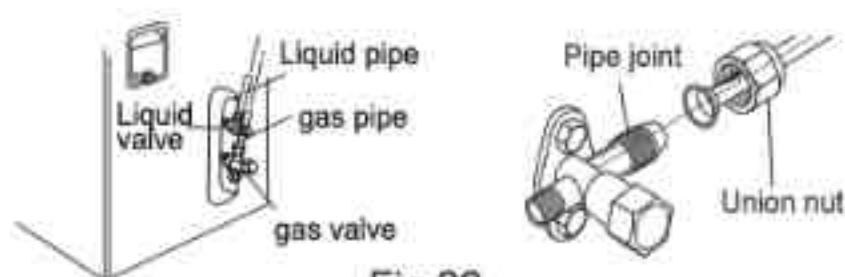

Fig.22

- (3) Pretightening the union nut with hand.
- (4) Tighten the union nut with torque wrench .

Refer to the following table for wrench moment of force :

| Hex nut diameter(inch) | Tightening torque(ft-lbf) |
|------------------------|---------------------------|
| Φ1/4                   | 11.10~14.75               |
| Φ3/8                   | 22.12~29.50               |
| Φ1/2                   | 33.19~40.56               |
| Φ5/8                   | 44.24~47.94               |
| Φ3/4                   | 51.32~55.31               |

### 5. Connect Outdoor Electric Wire

- (1) Let the connection wire sleeve go through the two holes of baffle; tighten the connection joint of sleeve and baffle; remove the wire clip; connect the power connection wire and power cord to the wiring terminal according to the color; fix them with screws.(As show in Fig.23)

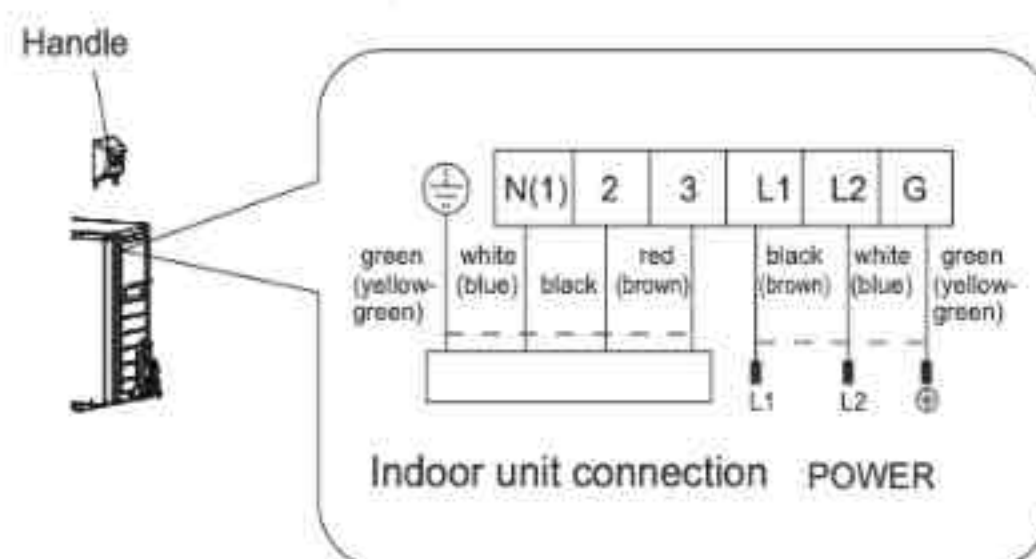

Note: the wiring board is for reference only, please refer to the actual one.

Fig.23

- (2) Fix the power connection wire and power cord with wire clip.
- (3) Fix the stopper on handle with screw.

**⚠ Note:**

- (1) After tightening the screw, pull the power cord slightly to check if it is firm.
- (2) Never cut the power connection wire to prolong or shorten the distance.

### 6. Neaten the Pipes

- (1) The pipes should be placed along the wall, bent reasonably and hidden possibly. Min. semidiameter of bending the pipe is 3 15/16inch.
- (2) If the outdoor unit is higher than the wall hole, you must set a U-shaped curve in the pipe before pipe goes into the room, in order to prevent rain from getting into the room.(As show in Fig.24)

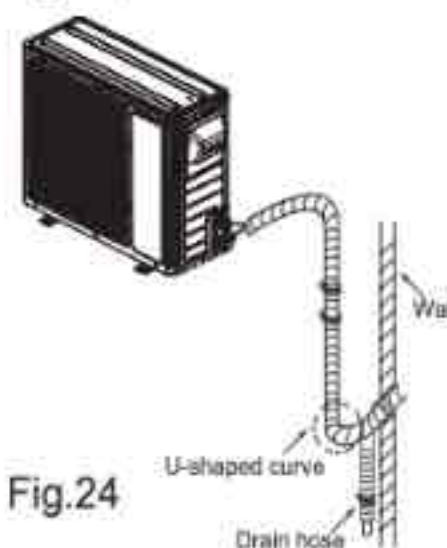

Fig.24

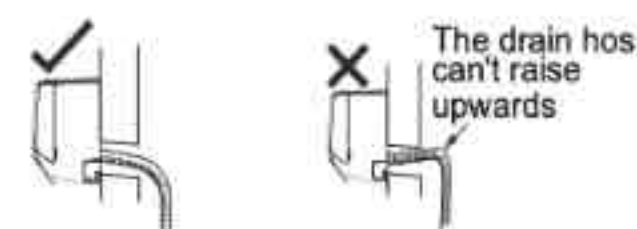
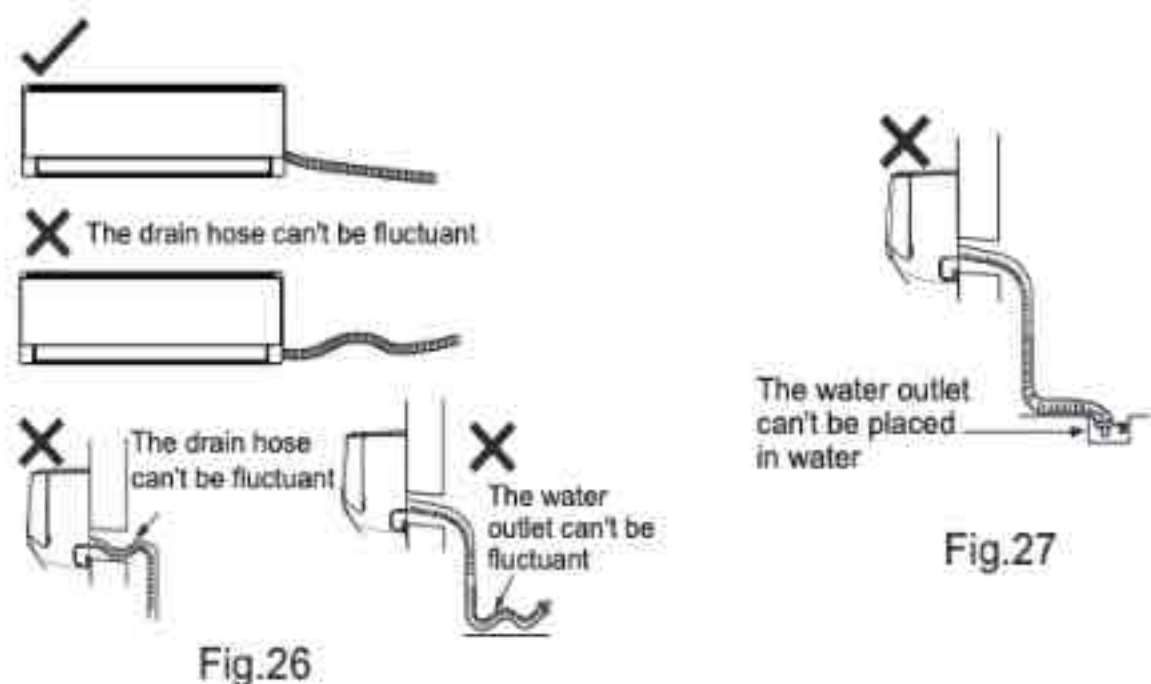

Fig.25

**⚠ Note:**

- (1) The through-wall height of drain hose shouldnt be higher than the outlet pipe hole of indoor unit.(As show in Fig.25)
- (2) Slant the drain hose slightly downwards. The drain hose cant be curved, raised and fluctuant, etc.(As show in Fig.26)

(3) The water outlet can't be placed in water in order to drain smoothly.(As show in Fig.27)



## 8.7 Vacuum Pumping and Leak Detection

### 1. Use Vacuum Pump

- (1) Remove the valve caps on the liquid valve and gas valve and the nut of refrigerant charging vent.
- (2) Connect the charging hose of piezometer to the refrigerant charging vent of gas valve and then connect the other charging hose to the vacuum pump.
- (3) Open the piezometer completely and operate for 10-15min to check if the pressure of piezometer remains in -14.5ISP.
- (4) Close the vacuum pump and maintain this status for 1-2min to check if the pressure of piezometer remains in -14.5ISP. If the pressure decreases, there may be leakage.
- (5) Remove the piezometer, open the valve core of liquid valve and gas valve completely with inner hexagon spanner.
- (6) Tighten the screw caps of valves and refrigerant charging vent.(As show in Fig.28)

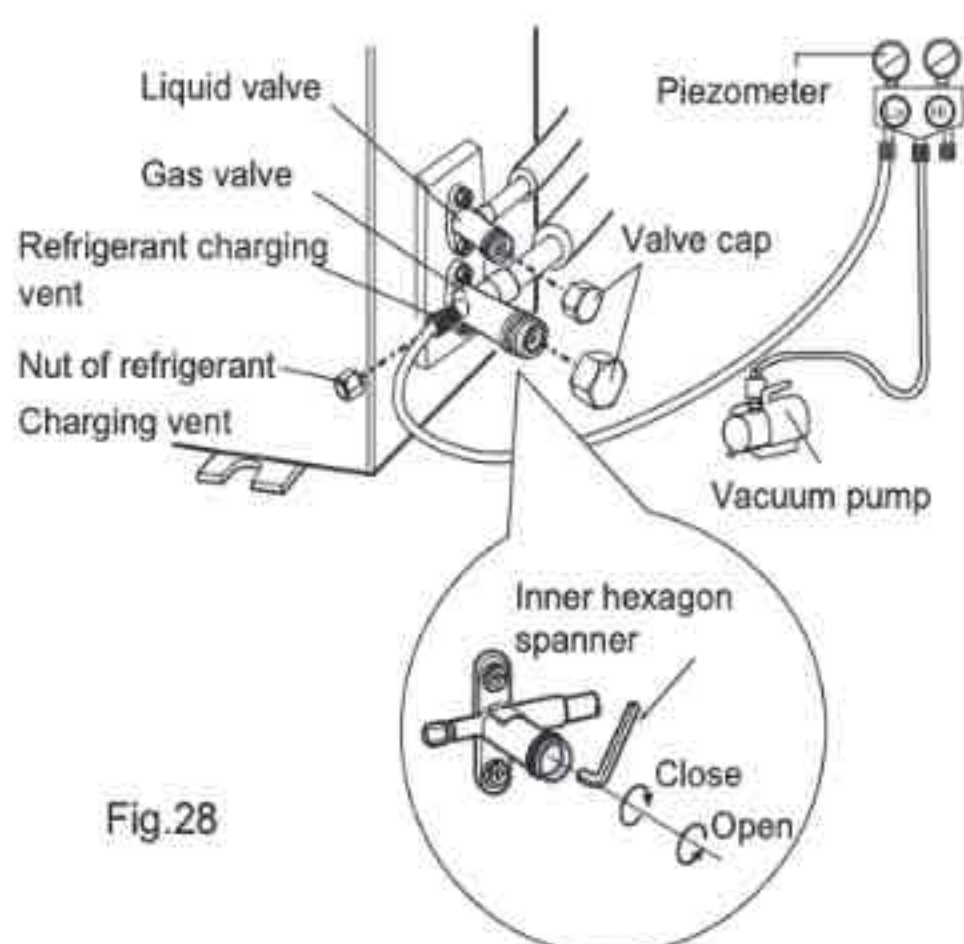

### 2. Leakage Detection

- (1) With leakage detector:  
Check if there is leakage with leakage detector.
- (2) With soap water:  
If leakage detector is not available, please use soap water for leakage detection. Apply soap water at the suspected position and keep the soap water for more than 3min. If there are air bubbles coming out of this position, theres a leakage.

## 8.8 Check after Installation and Test Operation

### 1. Check after Installation

Check according to the following requirement after finishing installation.

| NO. | Items to be checked  | Possible malfunction   |
|-----|--|--|
| 1   | Has the unit been installed firmly?  | The unit may drop, shake or emit noise.                                    |
| 2   | Have you done the refrigerant leakage test?                                      | It may cause insufficient cooling (heating) capacity.                      |
| 3   | Is heat insulation of pipeline sufficient?                                       | It may cause condensation and water dripping.                              |
| 4   | Is water drained well?   | It may cause condensation and water dripping.                              |
| 5   | Is the voltage of power supply according to the voltage marked on the nameplate? | It may cause malfunction or damage the parts.                              |
| 6   | Is electric wiring and pipeline installed correctly?                             | It may cause malfunction or damage the parts.                              |
| 7   | Is the unit grounded securely?   | It may cause electric leakage.   |
| 8   | Does the power cord follow the specification?                                    | It may cause malfunction or damage the parts.                              |
| 9   | Is there any obstruction in air inlet and air outlet?                            | It may cause insufficient cooling (heating) capacity.                      |
| 10  | The dust and sundries caused during installation are removed?                    | It may cause malfunction or damaging the parts.                            |
| 11  | The gas valve and liquid valve of connection pipe are open completely?           | It may cause insufficient cooling (heating) capacity.                      |
| 12  | Is the inlet and outlet of piping hole been covered?                             | It may cause insufficient cooling (heating) capacity or waster eletricity. |

### 2. Test Operation

- (1) Preparation of test operation
  - The client approves the air conditioner installation.
  - Specify the important notes for air conditioner to the client.
- (2) Method of test operation
  - Put through the power, press ON/OFF button on the remote controller to start operation.
  - Press MODE button to select AUTO, COOL, DRY, FAN and HEAT to check whether the operation is normal or not.
  - If the ambient temperature is lower than 16℃ , the air conditioner cant start cooling.

## 9. Maintenance

### 9.1 Precautions before Maintenance

There are high-capacity electrolytic capacitors on the outdoor mainboard. Thus, even the power is cut off, there is high voltage inside the capacitors and it needs more than 20min to reduce the voltage to safety value. Touching the electrolytic capacitor within 20min after cutting the power will cause electric shock. If maintenance is needed, follow the steps below to discharge electricity of electrolytic capacitor after power off.

(1) Open the top cover of outdoor unit and then remove the cover of electric box.

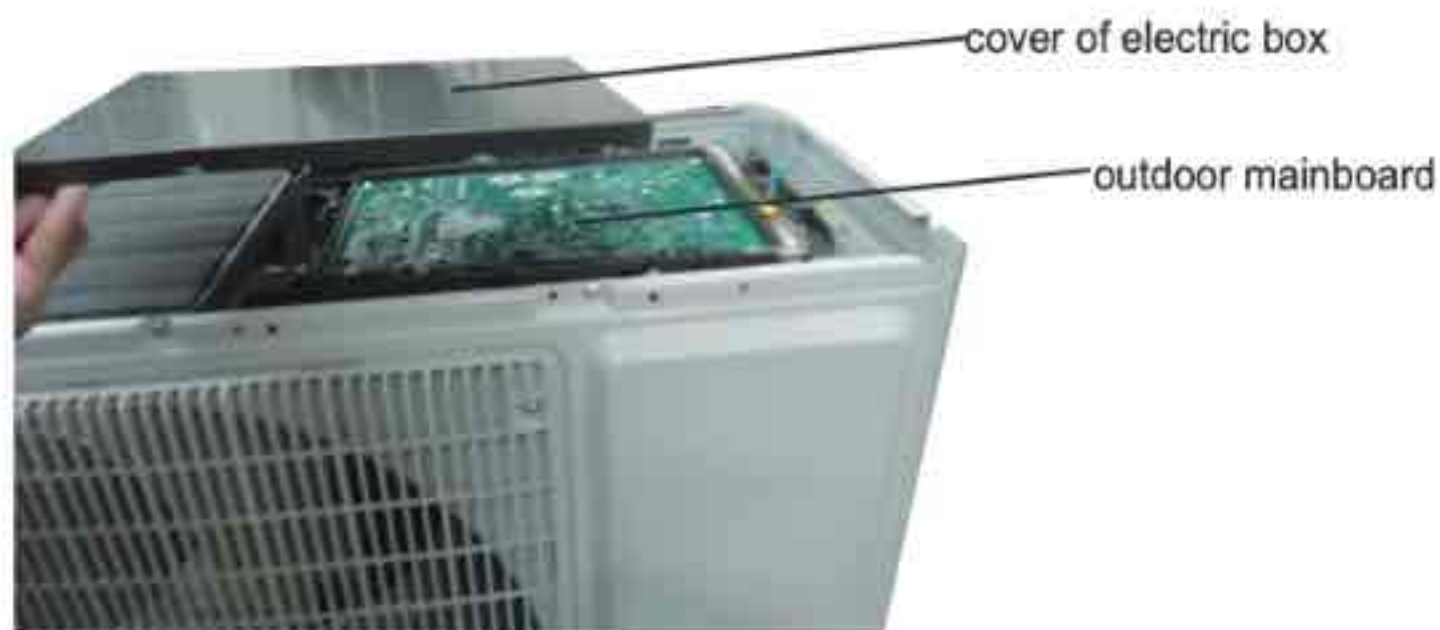

(2) As shown in the fig below, connect the plug of discharge resistance (about 100ohm, 20W) (if there is no discharge resistance, you can use the plug of soldering iron) to point A and B of electrolytic capacitor. There will be sparks when touching them. Press them forcibly for 30s to discharge electricity of electrolytic capacitor.

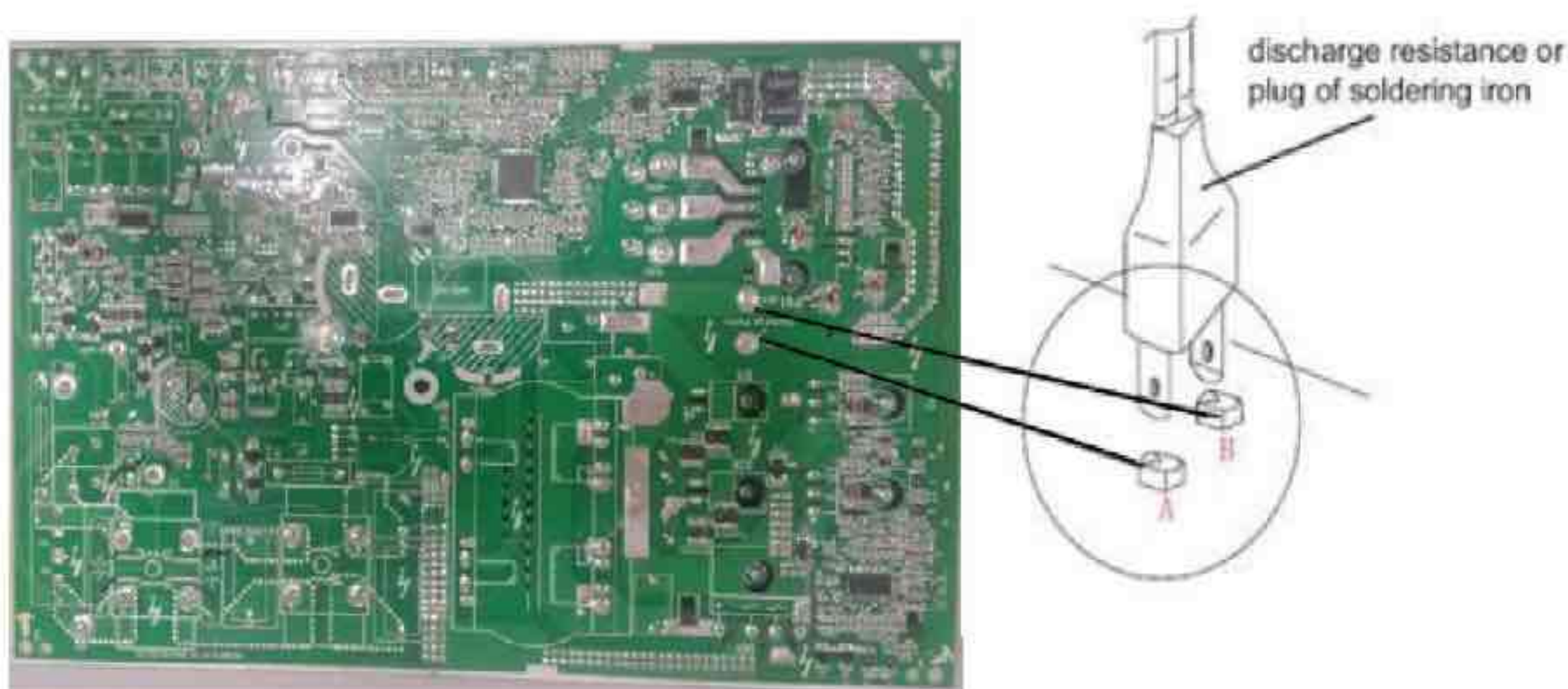

(3) After finish discharging electricity, measure the voltage between point A and B with universal meter to make sure if electricity discharging is completed, in order to prevent electric shock. If the voltage between the two points is below 20V, you can perform maintenance safely.

## 9.2 Error Code List

| NO. | Name of malfunction                                 | Indoor unit displaying method |  |                           |             | AC status  | Malfunctions   |
|-----|---|-------------------------------|--|---------------------------|-------------|--|--|
|     |   | Double 8 code display         | Indicator display(LED blinks 0.5s-ON/0.5s-OFF) |                           |             |  |  |
|     |   |                               | Running LED                                    | Cooling LED               | Heating LED |  |  |
| 1   | System high pressure protection                     | E1                            | 3s off blink once                              |                           |             | cooling,dehumidifying,except the indoor fan motor is running,others will stop to run.heating;all stop running          | High pressure of system,might be:<br>1.Refrigerant is too much;<br>2.Poor heating exchanging for units(including heat exchanger is dirty and unit heating radiating ambient is poor);<br>3.Ambient temp.is too high. |
| 2   | Anti-freezing protection                            | E2                            | 3s off blink twice                             |                           |             | cooling,dehumidifying,compressor,outdoor fan motor will stop running,indoor fan motor will keep running.               | 1.Poor indoor unit air returning;<br>2.Indoor fan motor rotating speed abnormal;<br>3.Evaporator is dirty;   |
| 3   | Compressor air exhaust high temp. protection        | E4                            | 3s off blink four times                        |                           |             | cooling,dehumidifying,compressor,outdoor fan motor will stop running,indoor fan motor works. heating;all stop running. | Pls refer to trouble shoot (air exhaust protection,overload)   |
| 4   | AC overload protection                              | E5                            | Off 3s blink 5 times                           |                           |             | Cooling,dehumidifying,compressor,outdoor fan motor will stop,indoor fan will work.heating;all will stop                | 1.power supply is stable,fluctuation is too much<br>2.Power supply is too low,overload is too much.  |
| 5   | Indoor and outdoor units communication malfunction  | E6                            | Off 3s blink 6 times                           |                           |             | Cooling,compressor will stop,indoor fan motor works,Heating;all will stop  | Please refer to troubleshooting  |
| 6   | Anti-high temp. protection                          | E8                            | Off 3s blink 8 times                           |                           |             | Cooling,compressor will stop,indoor fan motor works,Heating;all will stop  | Please refer to troubleshooting  |
| 7   | Indoor unit motor no feedback                       | H6                            | Off 3s blink 11 times                          |                           |             | Whole unit will stop to run  | 1.Poor insert for GPF<br>2.Indoor control board AP1 malfunction<br>3.Indoor motor M1 malfunction   |
| 8   | Jump wire cap malfunction protection                | C5                            | Off 3s blink 15 times                          |                           |             | Whole unit will stop to run  | Indoor control board AP1 jump cap poor connected,please reinsert or replace the jump cap.  |
| 9   | Indoor ambient sensor open circuit,short circuit    | F1                            |  | Off 3s blink once         |             | Cooling,dehumidifying:indoor fan motor is running,other overloads will stop;Heating,whole unit will stop to run.       | 1.Room temp.sensor is not connected with the control panel AP1<br>2.Room temp.sensor is damaged  |
| 10  | Indoor evaporator sensor circuit open,short circuit | F2                            |  | Off 3s blink twice        |             | Cooling,dehumidifying;indoor fan motor running,other overload will stop;Heating,whole unit will stop.                  | 1.Tube temp.sensor is not connected with the control panel AP1<br>2.Tube temp.sensor is damaged  |
| 11  | Outdoor ambient sensor circuit open,circuit short   | F3                            |  | Off 3s blinks three times |             | Cooling,dehumidifying;compressor will stop,indoor fan motor will work.Heat;all will stop                               | Outdoorroom temp.sensor hasn't connected well,or damaged,please refer to the sensor resistance value for checking.   |
| 12  | Outdoor condensor sensor open circuit,short circuit | F4                            |  | Off 3s blinks 4 times     |             | Cooling,dehumidifying;compressor will stop,indoor fan motor will work.Heat;all will stop                               | Outdoorroom temp.sensor hasn't connected well,or damaged,please refer to the sensor resistance value for checking.   |
| 13  | Malfunction of detecting plate(WIFI )               | JF                            |  |                           |             | Loads operate normally, while the unit can't be normally controlled by APP.  | 1.Main board of indoor unit is damaged<br>2.Detection board is damaged<br>3.The connection between indoor unit and detection board is not good   |

|    |   |    |  |   |  |  |  |
|----|---|----|--|---|--|--|--|
| 14 | Outdoor air exhaust sensor open circuit,short circuit | F5 |  | Off 3s blinks 5 times                                       |  | Cooling,dehumidifying;after runing for 3mins later,the compressor will stop to run,indoor fan motor will start to run.heating:after run 3 mins later,all will stop to run. | 1.Exhaust temp sensor hasn't connected well,or damaged,plwese refer to the sensor resistance value for checking.<br>2.Sensor head hasn't insert into the copper tube.  |
| 15 | Overload limit/descending frequency                   | F6 |  | Off 3s blinks 6 times                                       |  | Overload normal operation,compressor is runing,frequency descending  | Please refer to troubleshooting  |
| 16 | Over current need frequency descending                | F8 |  | Off 3s blinks 8 times                                       |  | Overload normal operation,compressor is runing,frequency descending  | 1.Input power supply is too low<br>2.System voltage is too high,over is too much   |
| 17 | Air exhaust over high need frequency descending       | F9 |  | Off 3s blinks 9 times                                       |  | Overload normal operation,compressor is runing,frequency descending  | 1.Overload is too much,ambient temp.is too high<br>2.Refrigerant is short<br>3.Electric expansion malfunction  |
| 18 | DC generatrix voltage is too high                     | PH |  | Off 3s blink 11 times                                       |  | Cooling,dehumidifying,co mpressor stop running,Fan motor works.<br>Heating: all will stop  | 1.Testing wire terminal L and N position.If higher than 265VAC,please cut off the power supply and restart until back to normal<br>2.If input voltage is normal, testing the voltage of electrolytic capacitor on AP1 after turn on the unit.There may be some problem and replace the AP1 if the electrolytic capacitor voltage range at 200-280V |
| 19 | Complete unit current detection malfunction           | U5 |  | Off 3s and blink 13 times                                   |  | Cooling, dehumidifying;compressor stops running,indoor fan motor works.<br>Heating: all will stop running  | The circuit on AP1 has malfunction, replace the outdoor unit AP1   |
| 20 | Compressor current overcurrent protection             | P5 |  | Off 3s blink 15 times                                       |  | Cooling, dehumidifying;compressor stops running,indoor fan motor works.<br>Heating: all will stop running  | Please refer to troubleshooting(IPM protection, compressor lose steps, compressor current overcurrent protection)  |
| 21 | Defrosting  |    |  | Off 3s and blink once (during blinking, ON 10s and Off 05s) |  | Defrosting will occur in heating mode.Compressor will operate while indoor fan will stop.  | It's the normal state  |
| 22 | Compressor overload protection                        | H3 |  | Off 3s blink 3 times  |  | Cooling, dehumidifying;compressor stops running,indoor fan motor works.<br>Heating: all will stop running  | 1. Wire terminal OVCCOMP loosen or circuit,has problem, the resistance of SAT should be lower than 1 ohm.<br>2.Please refer to troubleshooting(exhaust/ overload protection)   |
| 23 | IPM protection  | H5 |  | Off 3s blink 5 times  |  | Cooling, dehumidifying;compressor stops running,indoor fan motor works.<br>Heating: all will stop running  | Pis refer to troubleshooting   |
| 24 | PFC protection  | HC |  |   |  | Cooling, dehumidifying;compressor stops running,indoor fan motor works.<br>Heating: all will stop running  | Replace outdoor control panel AP1 or Reactor   |

|    |   |    |  |  |                             |  |   |
|----|---|----|--|--|-----------------------------|--|---|
| 25 | Compressor lose steps                                   | H7 |  |  | Off 3s<br>blink 7<br>times  | Cooling,<br>dehumidifying;compressor<br>stops running,indoor fan<br>motor works.<br>Heating: all will stop running | Pls refer to troubleshooting  |
| 26 | Heating, anti-<br>high temp.<br>declines                | H0 |  |  | Off 3s<br>blink 10<br>times | Overload normal<br>works,compressor<br>running,frequency declines  | Pls refer to troubleshooting  |
| 27 | Startup fail  | Lc |  |  | Off 3s<br>blink 11<br>times | Cooling,<br>dehumidifying;compressor<br>stops running,indoor fan<br>motor works.<br>Heating: all will stop running | Pls refer to troubleshooting  |
| 28 | Compressor<br>current<br>testing circuit<br>malfunction | U1 |  |  | Off 3s<br>blink 13<br>times |  | Replace the outdoor control<br>board AP1  |
| 29 | EEPROM<br>malfunction                                   | EE |  |  | Off 3s<br>blink 15<br>times | Cooling,<br>dehumidifying;compressor<br>stops running,indoor fan<br>motor works.<br>Heating: all will stop running | Replace the outdoor control<br>board AP1  |
| 30 | Capacitor<br>charge<br>malfunction                      | PU |  |  | Off 3s<br>blink 17<br>times | Cooling,<br>dehumidifying;compressor<br>stops running,indoor fan<br>motor works.<br>Heating: all will stop running | Pls refer to Part 3<br>capacitor charging fault of<br>troubleshooting   |
| 31 | Module sensor<br>circuit diagram                        | P7 |  |  | Off 3s<br>blink 18<br>times | Cooling,<br>dehumidifying;compressor<br>stops running,indoor fan<br>motor works.<br>Heating: all will stop running | Replace the outdoor control<br>board AP1  |
| 32 | Module temp.<br>over high<br>protection                 | P8 |  |  | Off 3s<br>blink 19<br>times | Cooling,<br>dehumidifying;compressor<br>stops running,indoor fan<br>motor works.<br>Heating: all will stop running | To check whether the<br>ambient Temp. of IPM is<br>too high or the heat-sinhing<br>of IPM is dirty else replace<br>the outdoor baord AP1  |
| 33 | DC Bus voltage<br>dips                                  | U3 |  |  | Off 3s<br>blink 20<br>times | Cooling,<br>dehumidifying;compressor<br>stops running,indoor fan<br>motor works.<br>Heating: all will stop running | Power voltage is not stable   |
| 34 | Low DC<br>Bus voltage<br>protection                     | PL |  |  | Off 3s<br>blink 21<br>times | Cooling,<br>dehumidifying;compressor<br>stops running,indoor fan<br>motor works.<br>Heating: all will stop running | 1.Check the Input voltage<br>if the Voltage is lower<br>than 150VAC,restart the<br>machine when the power<br>supply is normal.<br>2.Checking the reactor L<br>connection,   |
| 35 | IPM temp.is<br>too high limit/<br>decrease<br>frequency | EU |  |  |                             | Over load normal<br>works,compressor runing<br>frequency declines  | Whole unit break for 20<br>mins and discharge,to<br>check the outdoor control<br>board AP1's IPM module<br>coolant whether is short,the<br>radiator is tightened.<br>If above phenomenon is<br>not OK,Please improve or<br>replace the control board<br>AP1 |
| 36 | Four-way valve<br>abnormal                              | U7 |  |  |                             | This malfunction<br>happened,only in heating<br>mode,all will stop to run.   | 1.Power supply voltage is<br>lower than AC175V<br>2.Wire terminal 4V loosen<br>or wire break<br>3.4V damaged,replace 4V   |
| 37 | Outdoor unit<br>zero-cross<br>detecting error           |    |  |  |                             | Cooling:compressor will<br>stop,indoor fan motor works.<br>Heating:all will stop.                                  | Replace the outdoor control<br>board AP1  |
| 38 | Outdoor DC<br>fan motor<br>malfunction                  | L3 |  |  |                             | Outdoor DC fan motor<br>malfunction lead to<br>compressor stop<br>operation  | DC fan motor malfunction<br>or system blocked or the<br>connector loosed  |

|    |   |    |  |  |  |  |   |
|----|---|----|--|--|--|--|---|
| 39 | Anti-freezing protection for evaporator | E2 |  |  |  | Not the error code. It's the status code for the operation.  |   |
| 40 | Cold air prevention protection          | E9 |  |  |  | Not the error code. It's the status code for the operation.  |   |
| 41 | Refrigerant recovery mode               | Fo |  |  |  | Refrigerant recovery. The Serviceman operates it for maintenance.  |   |
| 42 | Undefined outdoor unit error            | oE |  |  |  | <p>Cool: compressor and outdoor fan stops operation, while indoor fan operates; Heat: compressor, outdoor fan and indoor fan stop operation.</p> | <ol style="list-style-type: none"> <li>1. Outdoor ambient temperature exceeds the operation range of unit (eg: less than -20°C or more than 60°C for cooling; more than 30°C for heating);</li> <li>2. Failure startup of compressor?</li> <li>3. Are wires of compressor not connected tightly?</li> <li>4. Is compressor damaged?</li> <li>5. Is main board damaged?</li> </ol> |

## 9.3 Troubleshooting for Main Malfunction

•Indoor unit:

### 1. Malfunction of Temperature Sensor F1, F2

Main detection points:

- Is the wiring terminal between the temperature sensor and the controller loosened or poorly contacted?
- Is there short circuit due to trip-over of the parts?
- Is the temperature sensor broken?
- Is mainboard broken?

Malfunction diagnosis process:

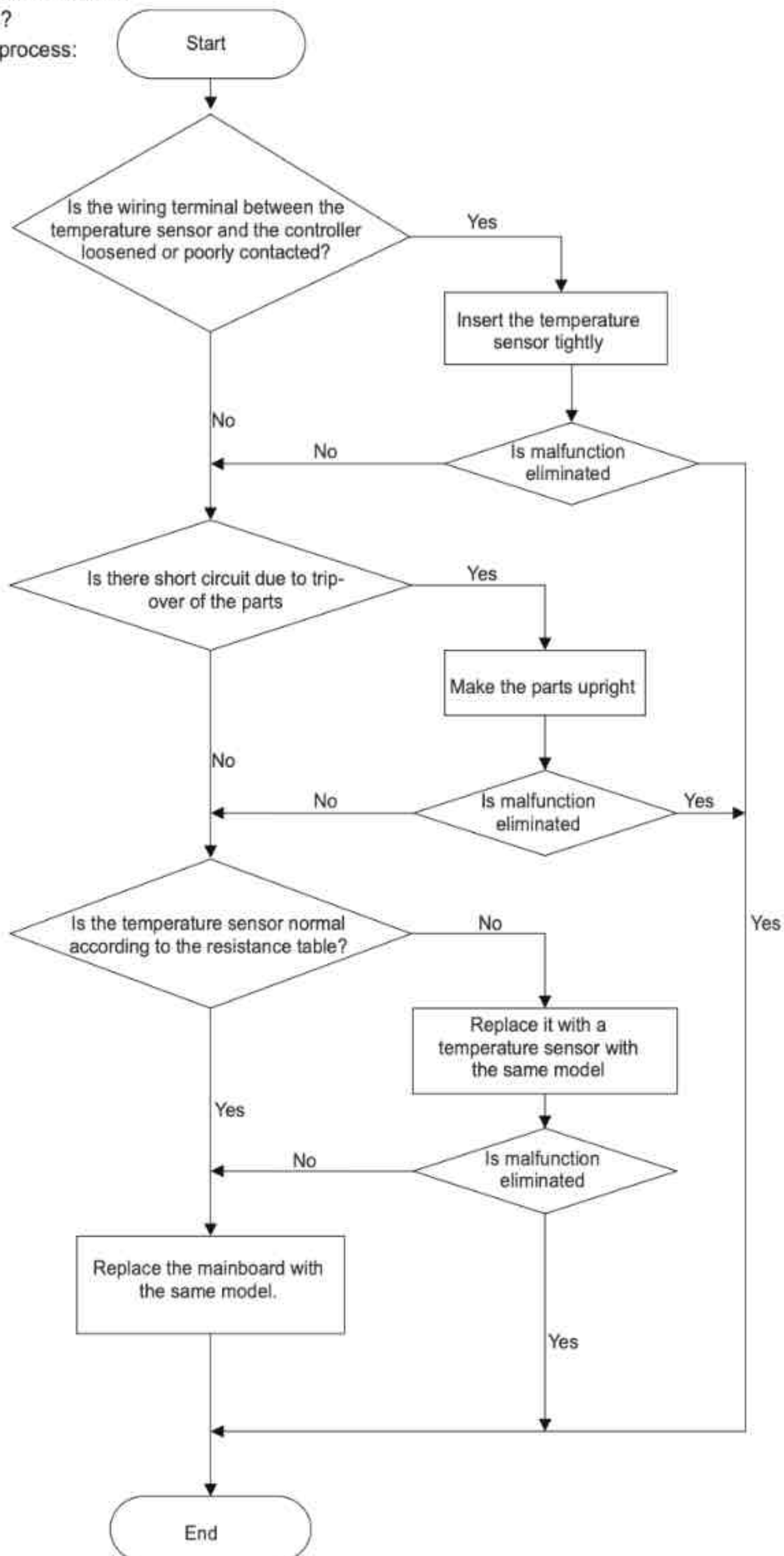

## 2. Malfunction of Blocked Protection of IDU Fan Motor H6

Main detection points:

- Smoothly is the control terminal of PG motor connected tightly?
- Smoothly is the feedback interface of PG motor connected tightly?
- The fan motor can't operate?
- The motor is broken?
- Detection circuit of the mainboard is defined abnormal?

Malfunction diagnosis process:

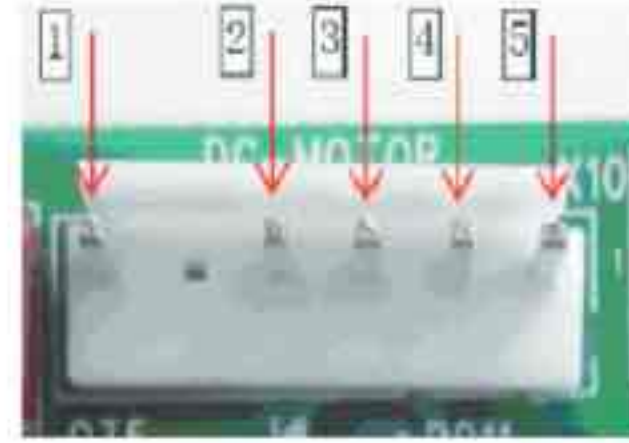
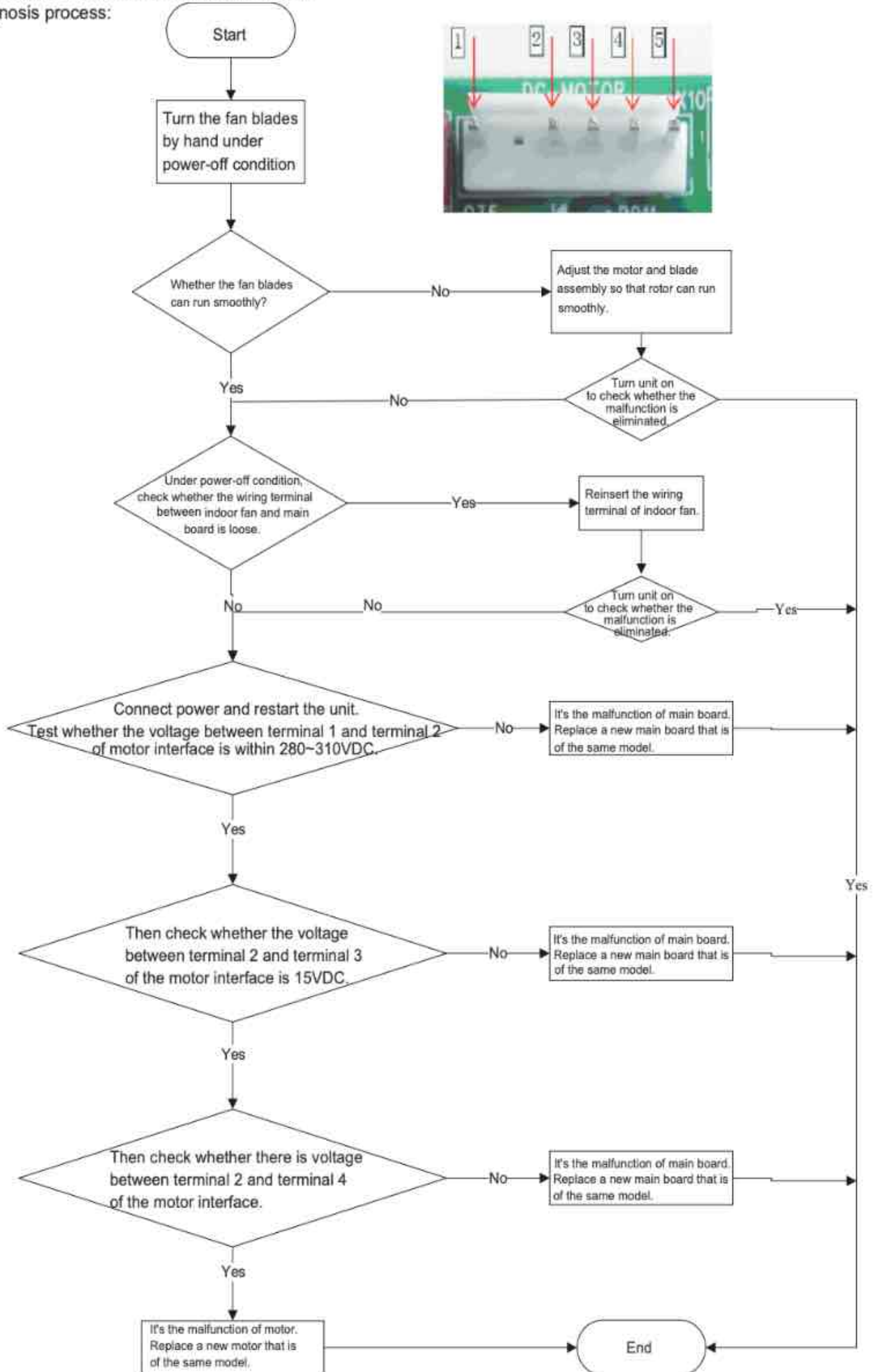

### 3. Malfunction of Protection of Jumper Cap C5

Main detection points:

- Is there jumper cap on the mainboard?
- Is the jumper cap inserted correctly and tightly?
- The jumper is broken?
- The motor is broken?
- Detection circuit of the mainboard is defined abnormal?

Malfunction diagnosis process:

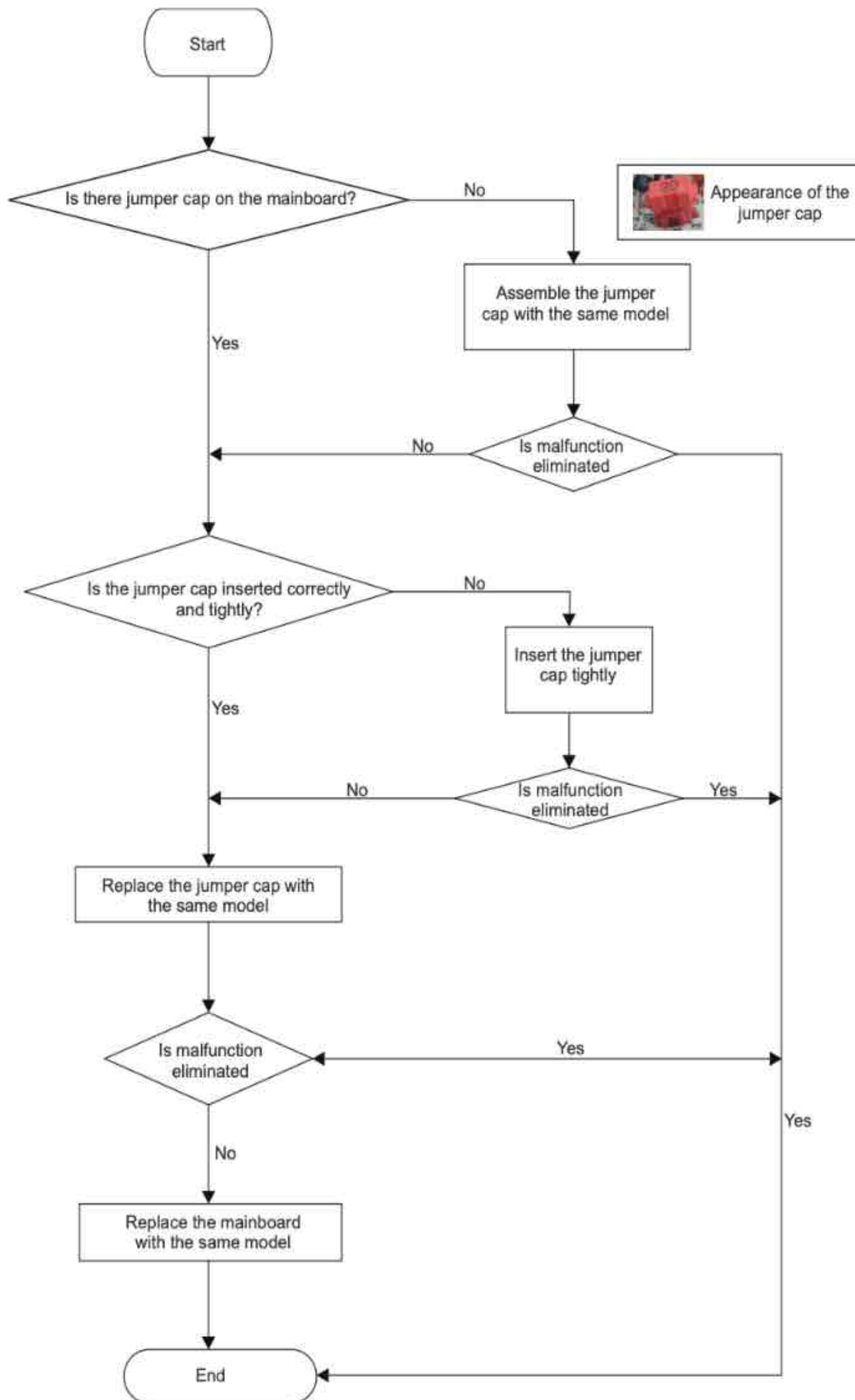



## 5. Malfunction of detecting plate(WIFI) JF

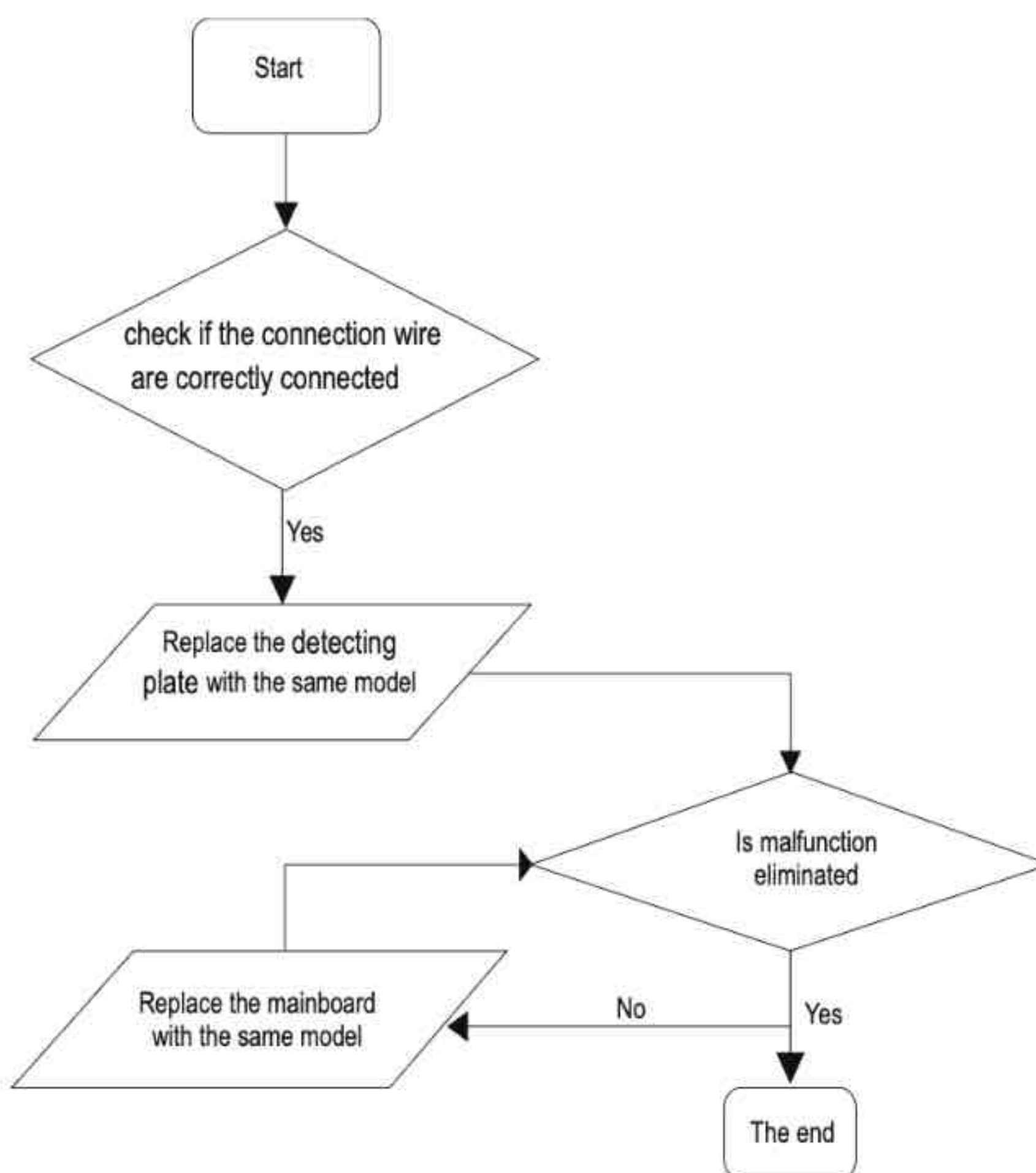

•Outdoor unit:

Key detection point

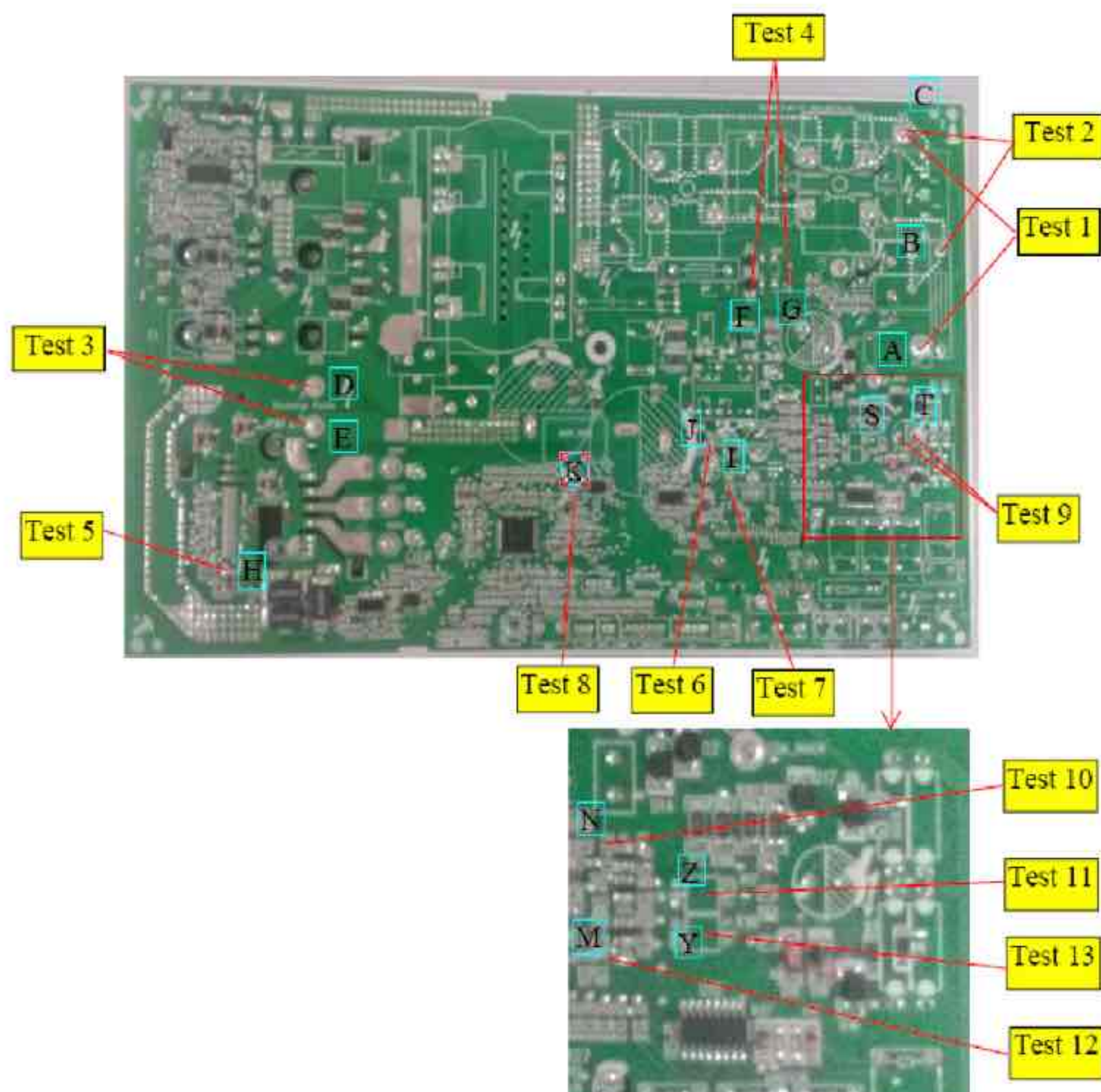

| "Test point NO." | Test point                              | Related elements   | Test value under normal condition |
|------------------|---|--|-----------------------------------|
| Test 1           | Between A and C                         | Neutral wire ,live wire  | 160V-265V                         |
| Test 2           | Between B and C                         | Neutral wire ,live wire  | 160V-265V                         |
| Test 3           | Between D and E                         | Electrolytic capacitor of DC bas bar                                   | DC 180V-380V                      |
| Test 4           | Between F and G                         | Electrolytic capacitor of switch power                                 | DC 180V-380V                      |
| Test 5           | Both ends of diode D59                  | D59(IPM module +15V)   | DC 14.5V-15.5                     |
| Test 6           | Both ends of electrolytic capacitor C47 | C47(+12V power)  | DC 12V-13V                        |
| Test 7           | Both ends of electrolytic capacitor C60 | C60(+5V power)   | DC 5V                             |
| Test 8           | Both ends of electrolytic capacitor C73 | C73(+3.3V power)   | DC 3.3V                           |
| Test 9           | Between S and T                         | Communication circular current   | DC 56V                            |
| Test 10          | Between point N and GND                 | C50 to N terminal (ground) (signal receiving terminal of outdoor unit) | Jumping between 0V and 3.3V       |
| Test 11          | U7                                      | Between 1 and 2 at leading foot of U7                                  | Jumping between 0V and 3.3V       |
| Test 12          | Between point M and GND                 | R77 to N terminal (ground) (signal receiving terminal of outdoor unit) | Jumping between 0V and 3.3V       |
| Test 13          | U8                                      | Between 3 and 4 at leading foot of U8                                  | Jumping between 0V and 3.3V       |

1.Capacity charging malfunction (outdoor unit malfunction) (AP1 below is control board of outdoor unit)

Main detection point:

- Detect if the voltage of L and N terminal of wiring board is between 210AC-240AC by alternating voltage meter;
- Is reactor (L) well connected? Is connection wire loosened or pull-out? Is reactor (L) damaged?

Malfunction diagnosis process:

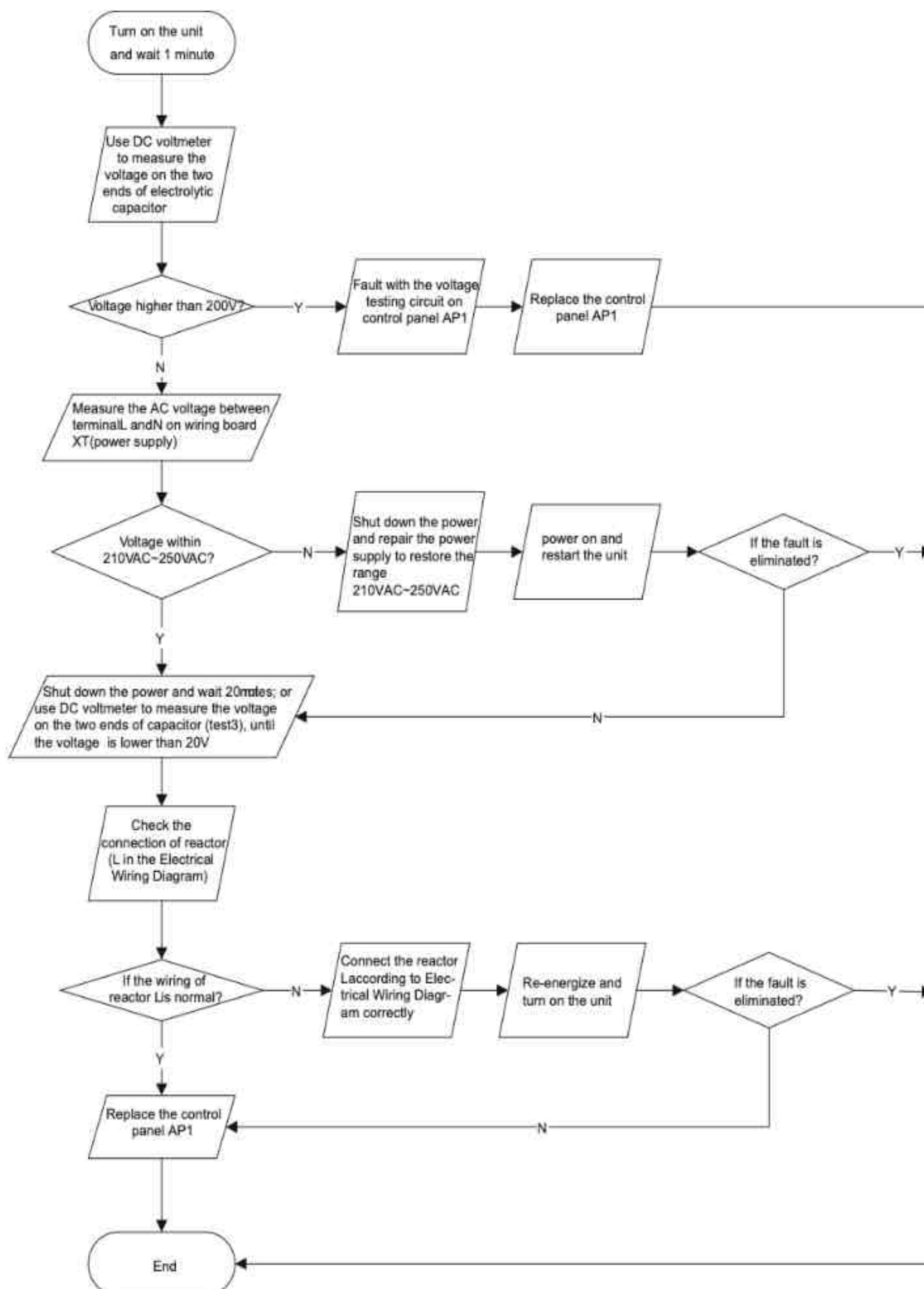

2. IPM protection, phase current overcurrent (the control board as below indicates the control board of outdoor unit) H5/P5

Mainly detect:

- (1) Compressor COMP terminal
- (2) voltage of power supply
- (3) compressor
- (4) Refrigerant-charging volume
- (5) air outlet and air inlet of outdoor/indoor unit

Troubleshooting:

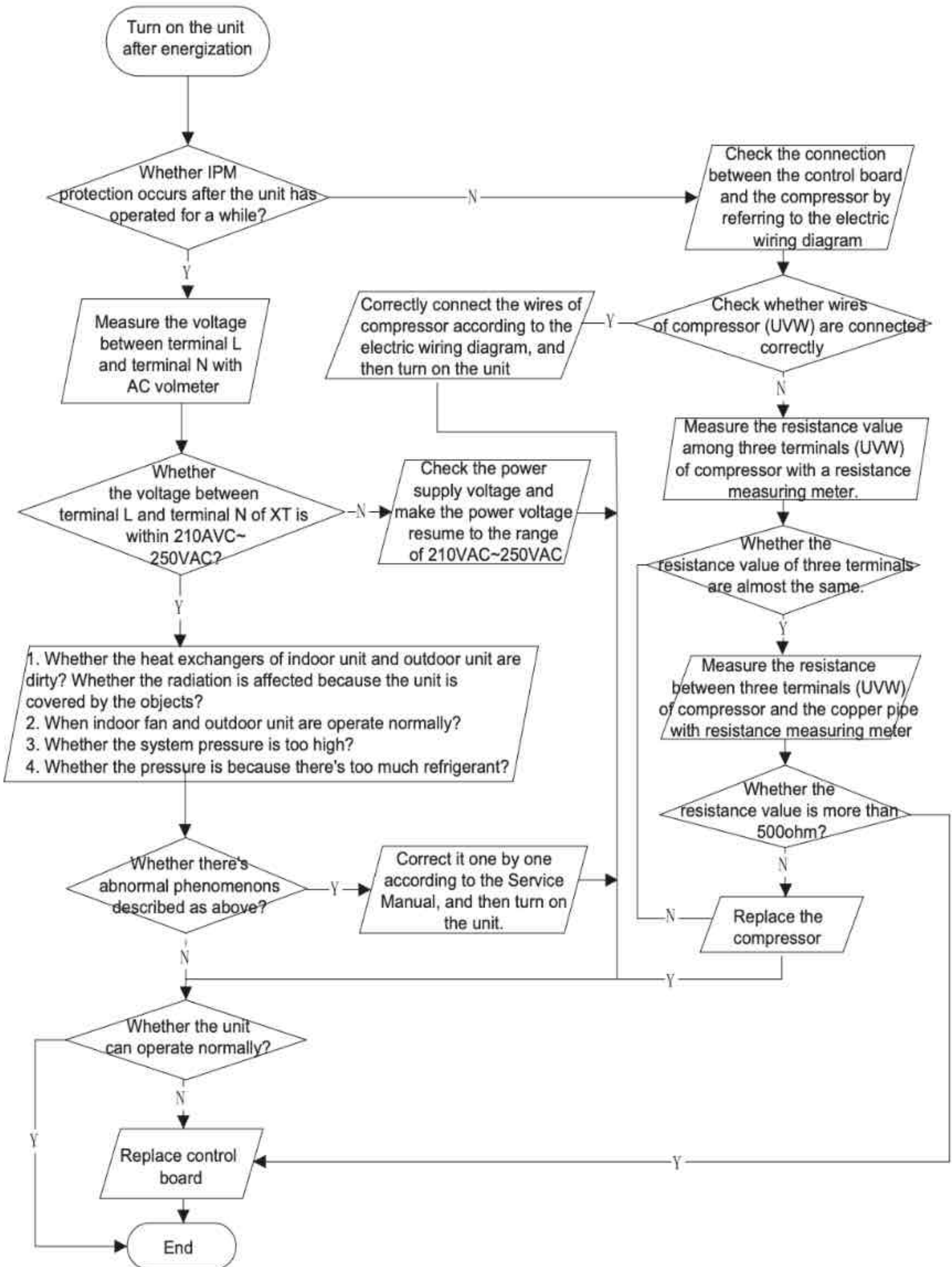

### 3.Diagnosis for anti-high temperature, overload protection (AP1 below is control board of outdoor unit)

Main detection point:

- If the outdoor ambient temperature is in normal range;
- If the indoor and outdoor fan is running normal;
- If the radiating environment of indoor and outdoor unit is well.

Malfunction diagnosis process:

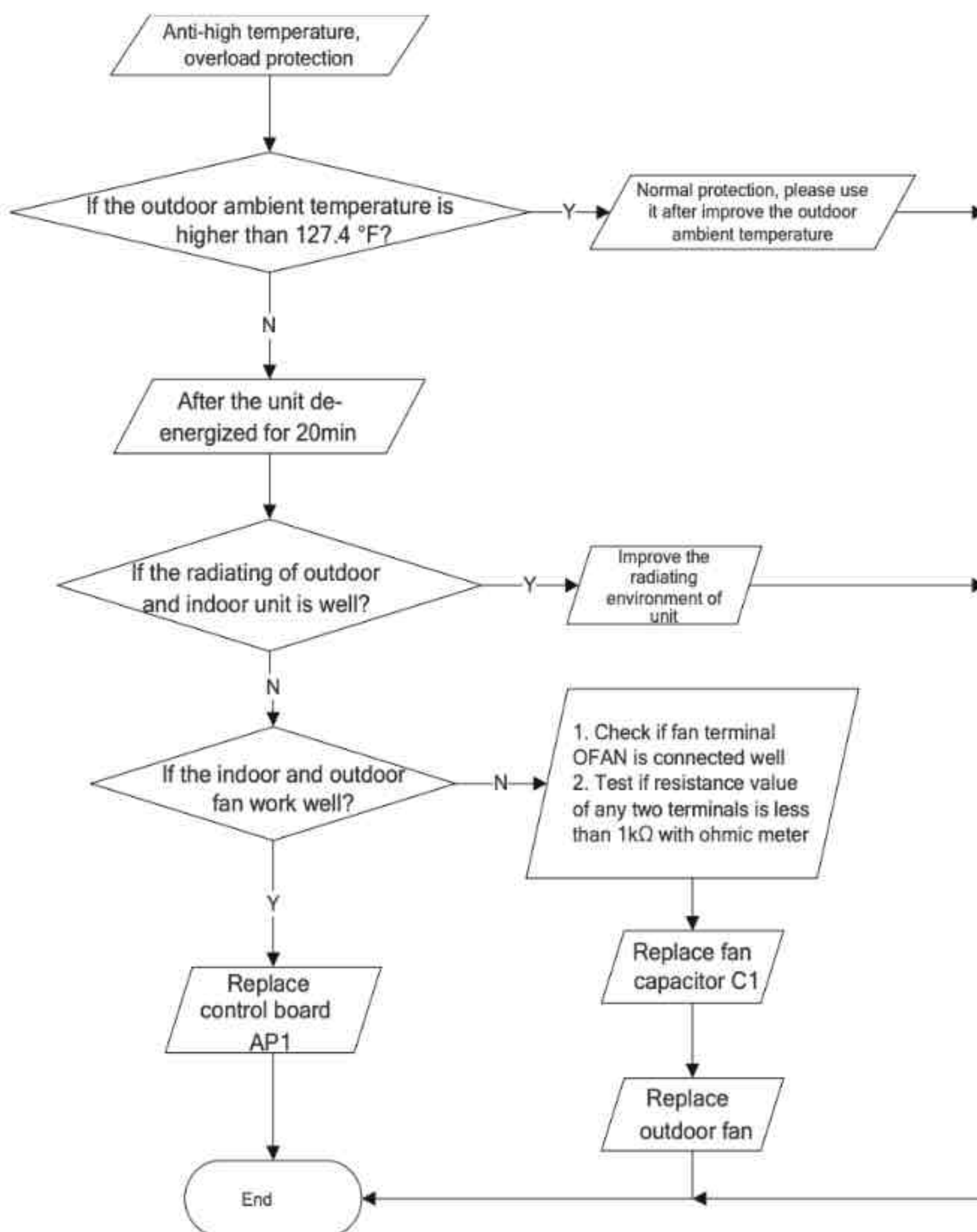

4.Diagnosis for failure start up malfunction (AP1 below is control board of outdoor unit)

Main detection point:

- If the compressor wiring is correct?
- If the stop time of compressor is enough?
- If the compressor is damaged?
- If the refrigerant charging is too much?

Malfunction diagnosis process:

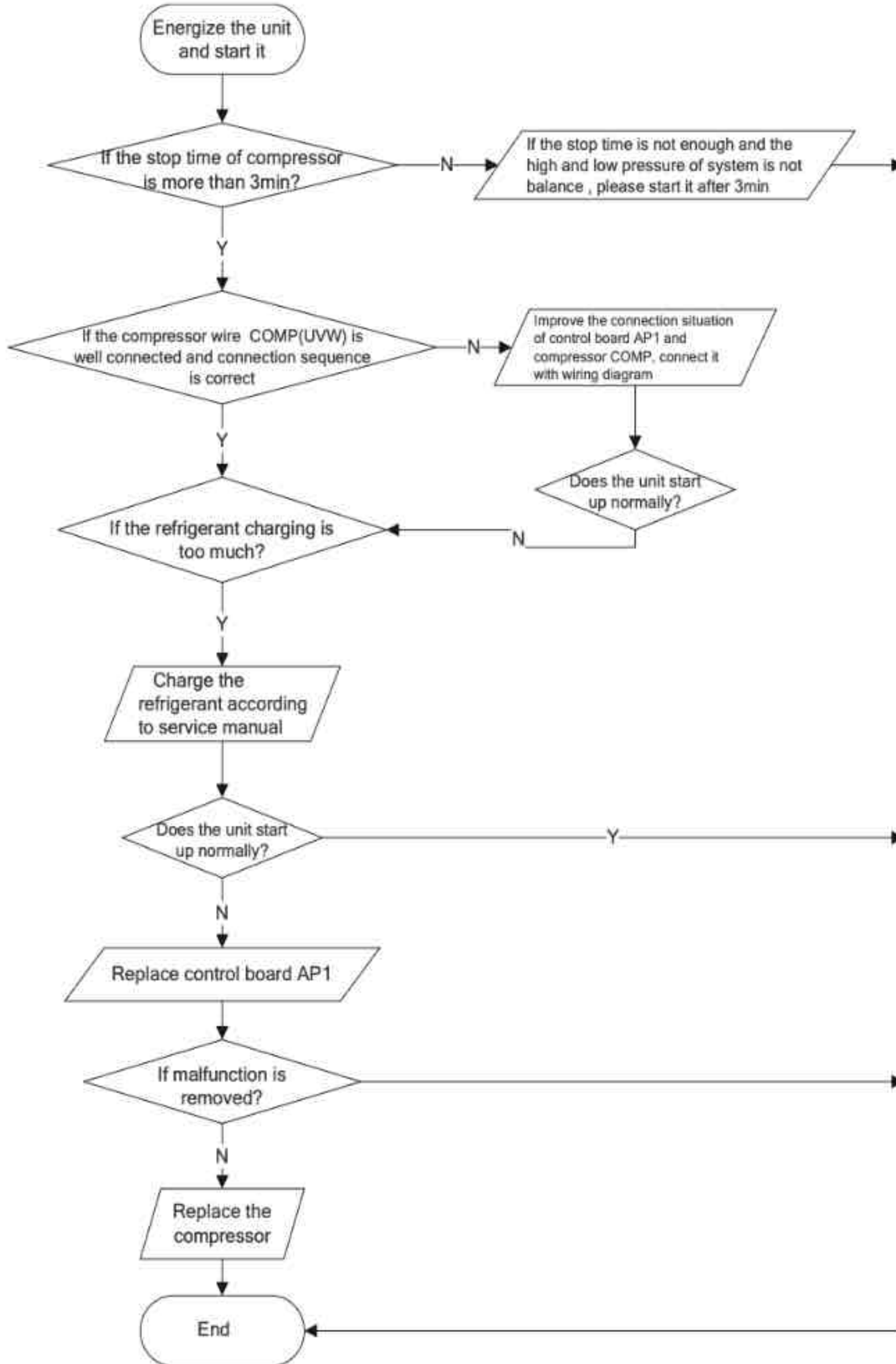

### 5. Diagnosis for compressor synchronism (AP1 below is control board of outdoor unit)

Main detection point:

- If the system pressure is over-high?
- If the work voltage is over-low?

Malfunction diagnosis process:



6. Diagnosis for overload and discharge malfunction (AP1 below is control board of outdoor unit)

Main detection point:

- If the electron expansion valve is connected well? Is the expansion valve damaged?
- If the refrigerant is leakage?
- If the overload protector is damaged?

Malfunction diagnosis process:

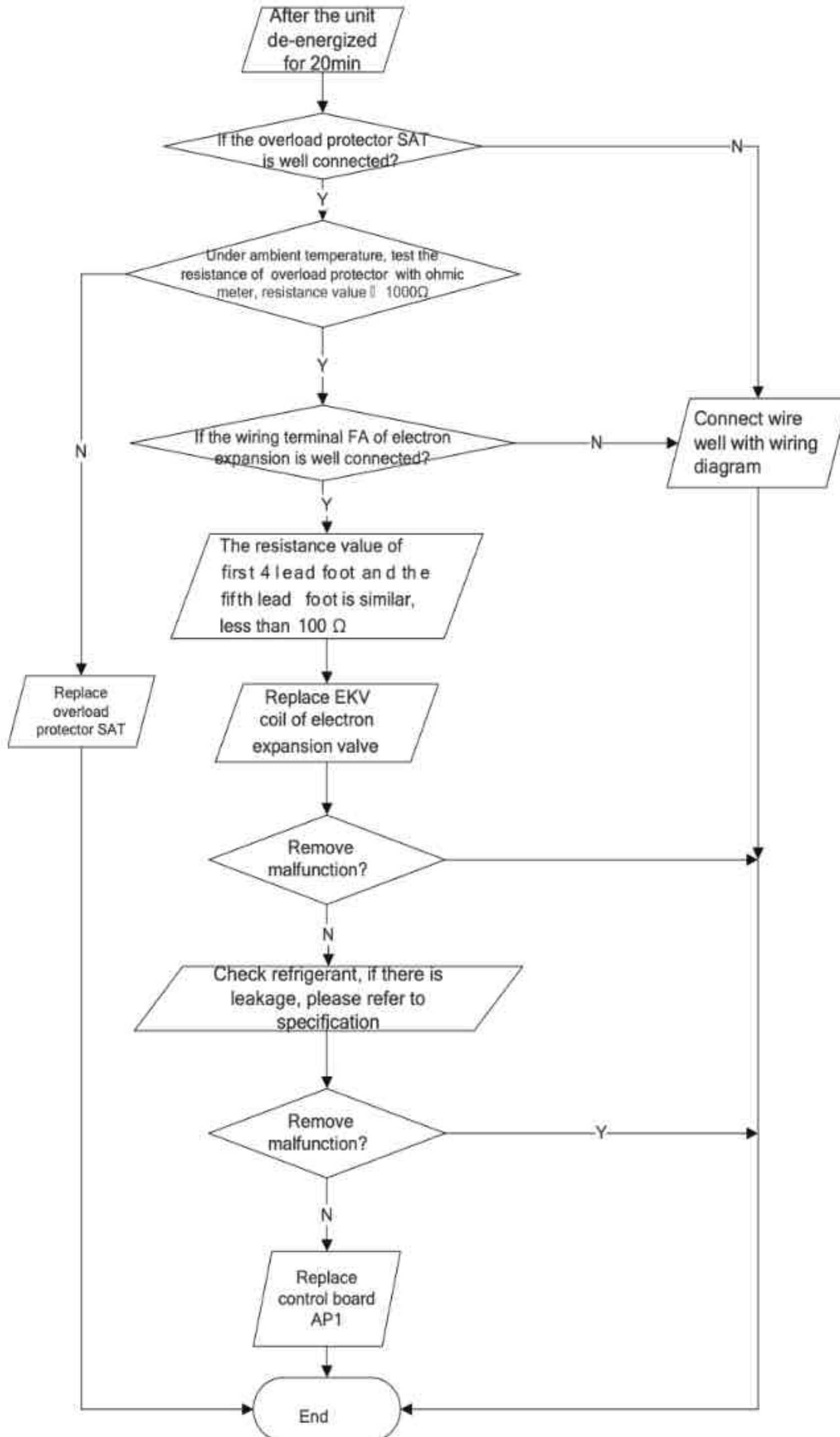

7. Communication malfunction (AP1 below is control board of outdoor unit)

Main detection point:

- Check if the connection wire and the built-in wiring of indoor and outdoor unit is connected well and no damaged;
- If the communication circuit of indoor mainboard is damaged? If the communication circuit of outdoor mainboard (AP1) is damaged

Malfunction diagnosis process:

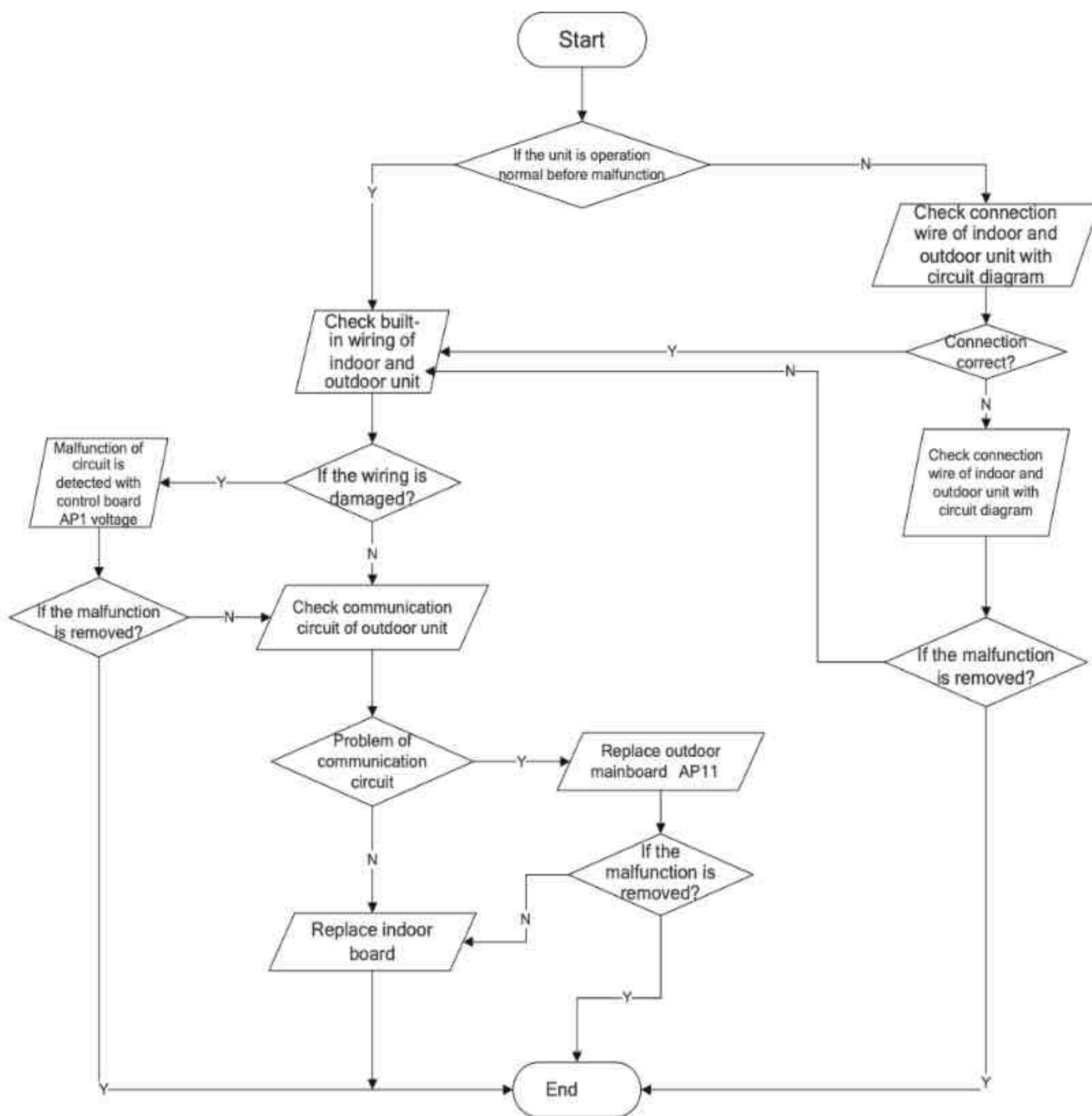



## 9.4 Troubleshooting for Normal Malfunction

### 1. Air conditioner cant be started up

| Possible Causes   | Discriminating Method (Air conditioner Status)  | Troubleshooting  |
|---|---|--|
| No power supply, or poor connection for power plug  | After energization, operation indicator isnt bright and the buzzer cant give out sound                              | Confirm whether its due to power failure. If yes, wait for power recovery. If not, check power supply circuit and make sure the power plug is connected well.  |
| Wrong wire connection between indoor unit and outdoor unit, or poor connection for wiring terminals | Under normal power supply circumstances, operation indicator isnt bright after energization                         | Check the circuit according to circuit diagram and connect wires correctly. Make sure all wiring terminals are connected firmly  |
| Electric leakage for air conditioner  | After energization, room circuit breaker trips off at once  | Make sure the air conditioner is grounded reliably<br>Make sure wires of air conditioner is connected correctly<br>Check the wiring inside air conditioner. Check whether the insulation layer of power cord is damaged; if yes, place the power cord. |
| Model selection for air switch is improper  | After energization, air switch trips off  | Select proper air switch   |
| Malfunction of remote controller  | After energization, operation indicator is bright, while no display on remote controller or buttons have no action. | Replace batteries for remote controller<br>Repair or replace remote controller   |

### 2. Poor cooling (heating) for air conditioner

| Possible Causes  | Discriminating Method (Air conditioner Status)   | Troubleshooting   |
|--|--|---|
| Set temperature is improper  | Observe the set temperature on remote controller   | Adjust the set temperature  |
| Rotation speed of the IDU fan motor is set too low                 | Small wind blow  | Set the fan speed at high or medium   |
| Filter of indoor unit is blocked                                   | Check the filter to see its blocked  | Clean the filter  |
| Installation position for indoor unit and outdoor unit is improper | Check whether the installation position is proper according to installation requirement for air conditioner  | Adjust the installation position, and install the rainproof and sunproof for outdoor unit |
| Refrigerant is leaking   | Discharged air temperature during cooling is higher than normal discharged wind temperature;<br>Discharged air temperature during heating is lower than normal discharged wind temperature;<br>Units pressure is much lower than regulated range   | Find out the leakage causes and deal with it.<br>Add refrigerant.                         |
| Malfunction of 4-way valve   | Blow cold wind during heating  | Replace the 4-way valve   |
| Malfunction of capillary   | Discharged air temperature during cooling is higher than normal discharged wind temperature;<br>Discharged air temperature during heating is lower than normal discharged wind temperature;<br>Unit pressure is much lower than regulated range. If refrigerant isnt leaking, part of capillary is blocked | Replace the capillary   |
| Flow volume of valve is insufficient                               | The pressure of valves is much lower than that stated in the specification   | Open the valve completely   |
| Malfunction of horizontal louver                                   | Horizontal louver cant swing   | Refer to point 3 of maintenance method for details  |
| Malfunction of the IDU fan motor                                   | The IDU fan motor cant operate   | Refer to troubleshooting for H6 for maintenance method in details                         |
| Malfunction of the ODU fan motor                                   | The ODU fan motor cant operate   | Refer to point 4 of maintenance method for details  |
| Malfunction of compressor  | Compressor cant operate  | Refer to point 5 of maintenance method for details  |

### 3. Horizontal louver cant swing

| Possible Causes                           | Discriminating Method (Air conditioner Status)              | Troubleshooting  |
|---|---|--|
| Wrong wire connection, or poor connection | Check the wiring status according to circuit diagram        | Connect wires according to wiring diagram to make sure all wiring terminals are connected firmly |
| Stepping motor is damaged                 | Stepping motor cant operate                                 | Repair or replace stepping motor   |
| Main board is damaged                     | Others are all normal, while horizontal louver cant operate | Replace the main board with the same model   |

## 4. ODU fan motor cant operate

| Possible causes                           | Discriminating method (air conditioner status)  | Troubleshooting  |
|---|---|--|
| Wrong wire connection, or poor connection | Check the wiring status according to circuit diagram  | Connect wires according to wiring diagram to make sure all wiring terminals are connected firmly |
| Capacity of the ODU fan motor is damaged  | Measure the capacity of fan capacitor with an universal meter and find that the capacity is out of the deviation range indicated on the nameplate of fan capacitor. | Replace the capacity of fan  |
| Power voltage is a little low or high     | Use universal meter to measure the power supply voltage. The voltage is a little high or low  | Suggest to equip with voltage regulator  |
| Motor of outdoor unit is damaged          | When unit is on, cooling/heating performance is bad and ODU compressor generates a lot of noise and heat.   | Change compressor oil and refrigerant. If no better, replace the compressor with a new one       |

## 5. Compressor cant operate

| Possible causes                           | Discriminating method (air conditioner status)  | Troubleshooting  |
|---|---|--|
| Wrong wire connection, or poor connection | Check the wiring status according to circuit diagram  | Connect wires according to wiring diagram to make sure all wiring terminals are connected firmly |
| Capacity of compressor is damaged         | Measure the capacity of fan capacitor with an universal meter and find that the capacity is out of the deviation range indicated on the nameplate of fan capacitor. | Replace the compressor capacitor   |
| Power voltage is a little low or high     | Use universal meter to measure the power supply voltage. The voltage is a little high or low  | Suggest to equip with voltage regulator  |
| Coil of compressor is burnt out           | Use universal meter to measure the resistance between compressor terminals and its 0  | Repair or replace compressor   |
| Cylinder of compressor is blocked         | Compressor cant operate   | Repair or replace compressor   |

## 6. Air conditioner is leaking

| Possible causes       | Discriminating method (air conditioner status)              | Troubleshooting                                     |
|-----------------------|---|---|
| Drain pipe is blocked | Water leaking from indoor unit                              | Eliminate the foreign objects inside the drain pipe |
| Drain pipe is broken  | Water leaking from drain pipe                               | Replace drain pipe                                  |
| Wrapping is not tight | Water leaking from the pipe connection place of indoor unit | Wrap it again and bundle it tightly                 |

## 7. Abnormal sound and vibration

| Possible causes  | Discriminating method (air conditioner status)                   | Troubleshooting   |
|--|--|---|
| When turn on or turn off the unit, the panel and other parts will expand and theres abnormal sound         | Theres the sound of "PAPA"                                       | Normal phenomenon. Abnormal sound will disappear after a few minutes.   |
| When turn on or turn off the unit, theres abnormal sound due to flow of refrigerant inside air conditioner | Water-running sound can be heard                                 | Normal phenomenon. Abnormal sound will disappear after a few minutes.   |
| Foreign objects inside the indoor unit or therere parts touching together inside the indoor unit           | Theres abnormal sound fro indoor unit                            | Remove foreign objects. Adjust all parts position of indoor unit, tighten screws and stick damping plaster between connected parts  |
| Foreign objects inside the outdoor unit or therere parts touching together inside the outdoor unit         | Theres abnormal sound fro outdoor unit                           | Remove foreign objects. Adjust all parts position of outdoor unit, tighten screws and stick damping plaster between connected parts |
| Short circuit inside the magnetic coil   | During heating, the way valve has abnormal electromagnetic sound | Replace magnetic coil   |
| Abnormal shake of compressor   | Outdoor unit gives out abnormal sound                            | Adjust the support foot mat of compressor, tighten the bolts  |
| Abnormal sound inside the compressor   | Abnormal sound inside the compressor                             | If add too much refrigerant during maintenance, please reduce refrigerant properly. Replace compressor for other circumstances.     |

# 10. Exploded View and Parts List

## 10.1 Indoor Unit

TW18HQ3C2DI

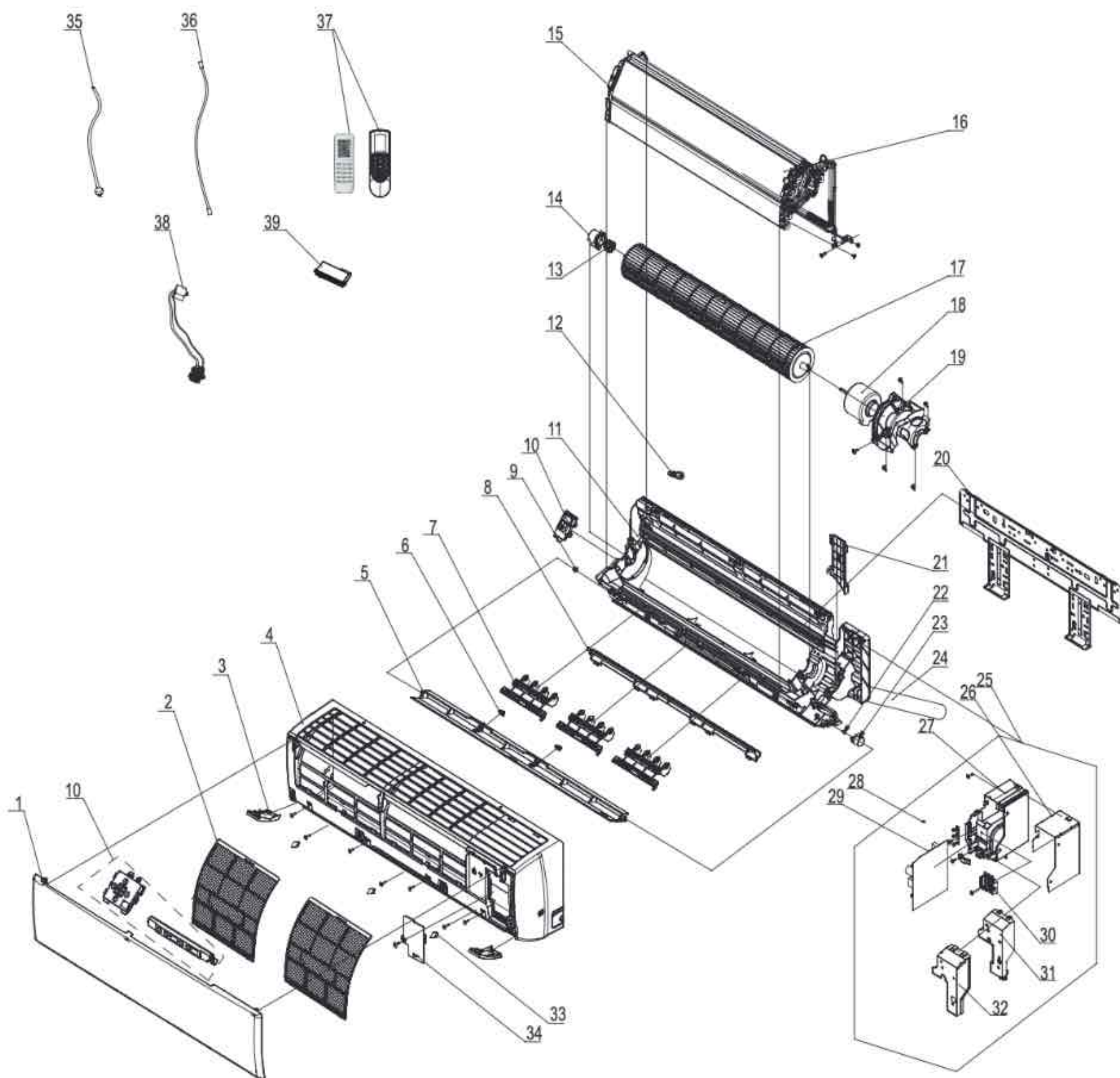

The component picture is only for reference; please refer to the actual product.

| NO. | Description                      | Part Code                          | Qty |
|-----|----------------------------------|------------------------------------|-----|
|     |                                  | TW18HQ3C2DI                        |     |
|     |                                  | Product Code<br>CB439N11600_X40891 |     |
| 1   | Front Panel                      | 20000300070S                       | 1   |
| 2   | Filter Sub-Assy                  | 11122089                           | 2   |
| 3   | Decoration board(left and right) | 20192662                           | 1   |
| 4   | Front Case                       | 2002248401                         | 1   |
| 5   | Guide Louver                     | 1051276501                         | 1   |
| 6   | Axile Bush                       | 10542036                           | 2   |
| 7   | Air Louver(Manual)               | 10512732                           | 3   |
| 8   | Helicoid Tongue                  | 26112512                           | 1   |
| 9   | Left Axile Bush                  | 10512037                           | 1   |
| 10  | Display Board                    | 30565278                           | 1   |
| 11  | Rear Case assy                   | 22202571                           | 1   |
| 12  | Rubber Plug (Water Tray)         | 76712012                           | 1   |
| 13  | O-Gasket sub-assy of Bearing     | 7651205102                         | 1   |
| 14  | O-Gasket of Cross Fan Bearing    | 76512203                           | 1   |
| 15  | Evaporator Support               | 24212177                           | 1   |
| 16  | Evaporator Assy                  | 011001000207                       | 1   |
| 17  | Cross Flow Fan                   | 10352060                           | 1   |
| 18  | Fan Motor                        | 1501214503                         | 1   |
| 19  | Motor Press Plate                | 26112511                           | 1   |
| 20  | Wall Mounting Frame              | 01362026                           | 1   |
| 21  | Connecting pipe clamp            | 2611218801                         | 1   |
| 22  | Crank                            | 73012005                           | 1   |
| 23  | Stepping Motor                   | 1521240212                         | 1   |
| 24  | Drainage Hose                    | 05230014                           | 1   |
| 25  | Electric Box Assy                | 100002002705                       | 1   |
| 26  | Lower Shield of Electric Box     | 01592139                           | 1   |
| 27  | Electric Box                     | 2011221102                         | 1   |
| 28  | Jumper                           | 4202021919                         | 1   |
| 29  | Main Board                       | 300002000312                       | 1   |
| 30  | Terminal Board                   | 42011233                           | 1   |
| 31  | Electric Box Cover               | 2011220901                         | 1   |
| 32  | Shield Cover of Electric Box     | 01592176                           | 1   |
| 33  | Screw Cover                      | 2425201726                         | 3   |
| 34  | Electric Box Cover2              | 2011221001                         | 1   |
| 35  | Power Cord                       | /                                  | /   |
| 36  | Connecting Cable                 | /                                  | /   |
| 37  | Remote Controller                | 305001000085                       | 1   |
| 38  | Cold Plasma Generator            | /                                  | /   |
| 39  | Detecting plate(WIFI)            | 30070077                           | 1   |

Above data is subject to change without notice.



| No. | Description                     | Part Code          | Qty |
|-----|---------------------------------|--------------------|-----|
|     |                                 | TW18HQ3C2DO        |     |
|     | Product Code                    | CB425W07400_X40891 |     |
| 1   | Front Grill                     | 01473049           | 1   |
| 2   | Cabinet                         | 01433047P          | 1   |
| 3   | Axial Flow Fan                  | 10335008           | 1   |
| 4   | Fan Motor                       | 1501506402         | 1   |
| 5   | Chassis Sub-assy                | 01700000093P       | 1   |
| 6   | Drainage hole Cap               | 06813401           | 3   |
| 7   | Clapboard Assy                  | 01233153           | 1   |
| 8   | 4-Way Valve Assy                | 030152000291       | 1   |
| 9   | Compressor and Fittings         | 00105249G          | 1   |
| 10  | Valve Support Assy              | 01715010P          | 1   |
| 11  | Cut off Valve                   | 07130239           | 1   |
| 12  | Cut off Valve Sub-Assy          | 07133204           | 1   |
| 13  | Right Side Plate                | 0130509403P        | 1   |
| 14  | Valve Cover                     | 22245002           | 1   |
| 15  | Retaining Plate                 | 02115006P          | 1   |
| 16  | Handle Assy                     | 02113109           | 1   |
| 17  | Valve Support Block             | /                  | /   |
| 18  | Temperature Sensor              | 3900030901         | 1   |
| 19  | Rear Grill                      | 01473043           | 1   |
| 20  | Condenser Assy                  | 011002000513       | 1   |
| 21  | Coping                          | 012049000007P      | 1   |
| 22  | Motor Support Sub-Assy          | 01703154           | 1   |
| 23  | Condenser Support Plate         | 01173127           | 1   |
| 24  | Left Side Plate                 | 01305093P          | 1   |
| 25  | Handle                          | 26233053           | 1   |
| 26  | Electric Box Assy               | 100002001525       | 1   |
| 27  | Terminal Board                  | 42200006001401     | 1   |
| 28  | Electric Box                    | 20113027           | 1   |
| 29  | Main Board                      | 300027000297       | 1   |
| 30  | Radiator                        | 49013076/49013060  | 1   |
| 31  | Electronic Expansion Valve assy | 030026000208       | 1   |

Above data is subject to change without notice.

# 11. Removal Procedure

## 11.1 Removal Procedure of Indoor Unit



**Warning:** Be sure to wait for a minimum of 20 minutes after turning off all power supplies and discharge the refrigerant completely before removal.

| Step                        | Procedure  |  |
|-----------------------------|--|--|
| 1. Remove filter assy       | <p>Open the front panel. Push the left and right filters to make them break away from the groove on the front case. Then remove the left and right filters one by one.</p>   |  |
| 2. Remove horizontal louver | <p>Push out the axile bush on horizontal louver. Bend the horizontal louver with hand and then separate the horizontal louver from the crankshaft of step motor to remove it.</p>  |  |
| 3. Remove panel             | <p>a Screw off the 2 screws that are locking the display board. Separate the display board from the front panel.</p> <p>b Separate the panel rotation shaft from the groove fixing the front panel and then removes the front panel.</p> |  |



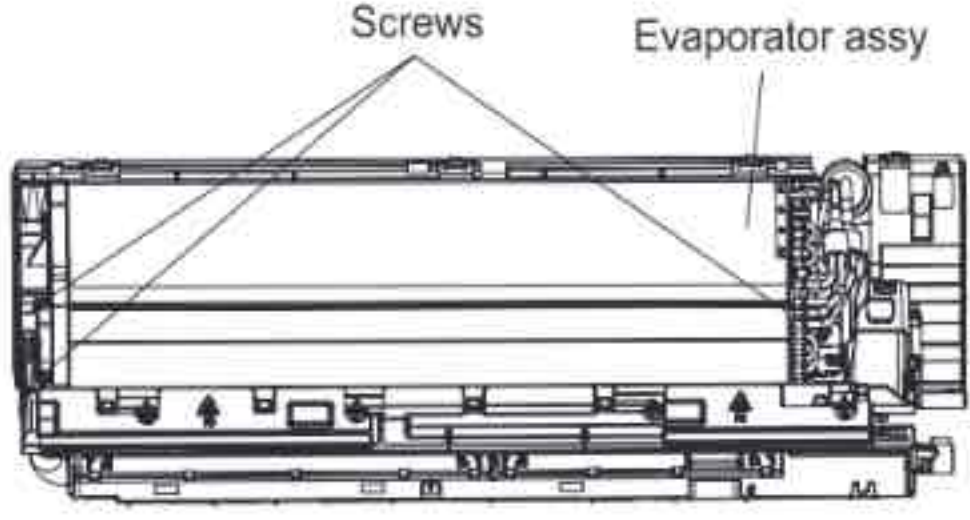
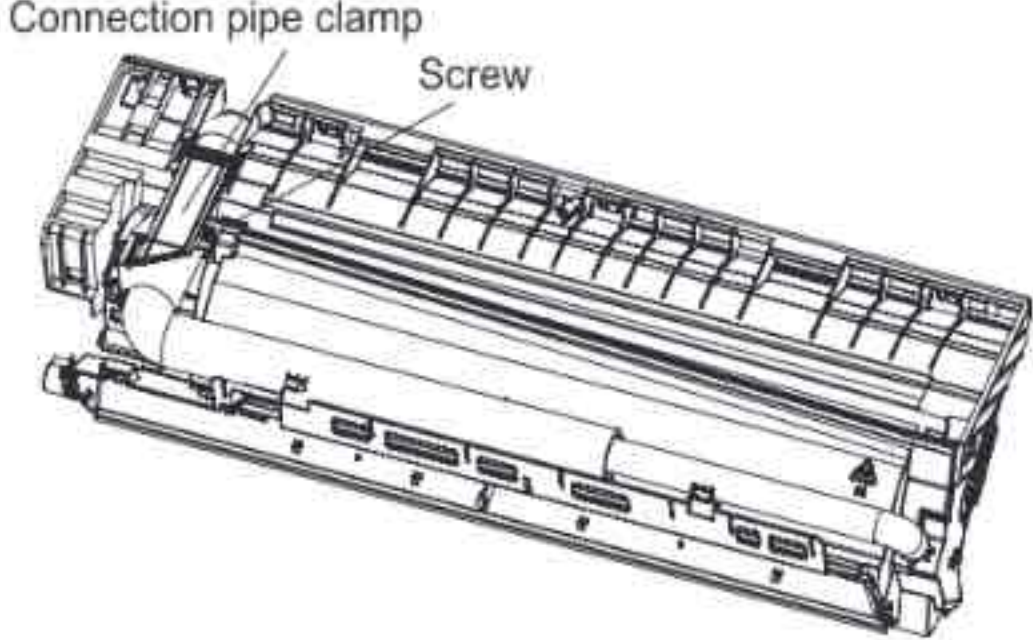
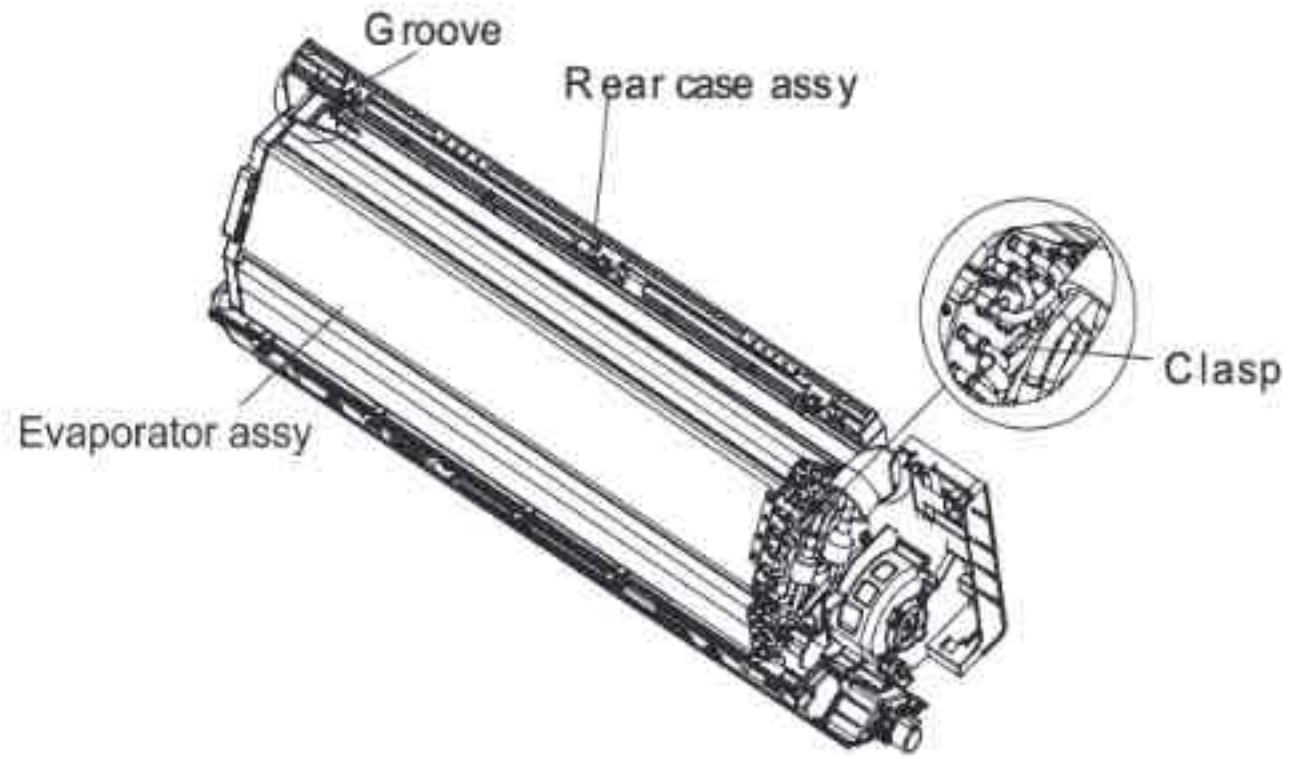
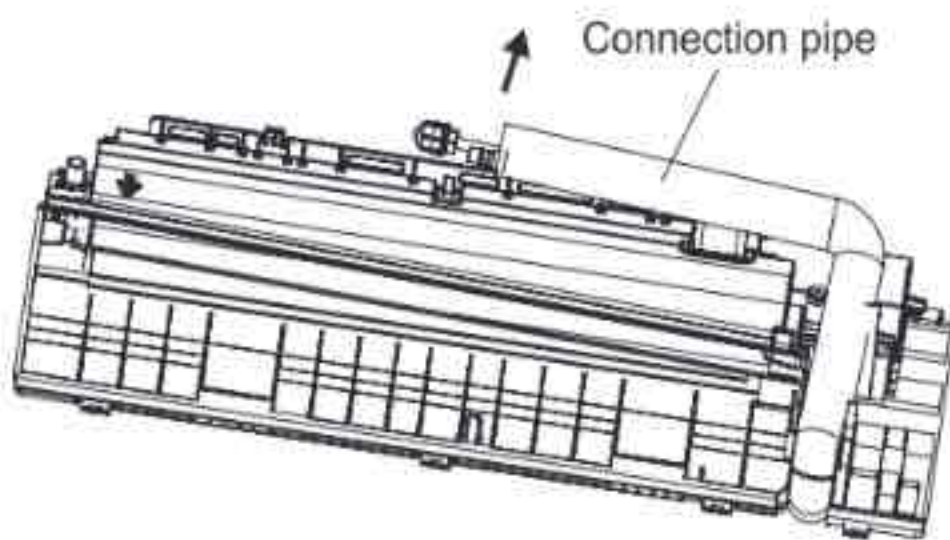

| Step                      | Procedure  | Diagram   |
|---------------------------|--|---|
| 8. Remove evaporator assy |  |   |
| a                         | Remove 3 screws fixing evaporator assy.  |    |
| b                         | At the back of the unit, remove the screw fixing connection pipe clamp and then remove the connection pipe clamp.                                |  |
| c                         | First remove the left side of evaporator from the groove on the rear case assy. Then remove the right side from the clasp on the rear case assy. |   |
| d                         | Adjust the position of connection pipe on evaporator slightly and then lift the evaporator upwards to remove it.                                 |  |

| Step                                 | Procedure  |
|--------------------------------------|--|
| 9. Remove motor and cross flow blade |  |
| a                                    | <p>Remove the screws fixing motor clamp and then remove the motor clamp.</p>   |
| b                                    | <p>Remove the screws at the connection place of cross flow blade and motor; lift the motor and cross flow blade upwards to remove them.<br/>                     Remove the bearing holder sub-assy.<br/>                     Remove the screw fixing step motor and then remove the step motor.</p> |

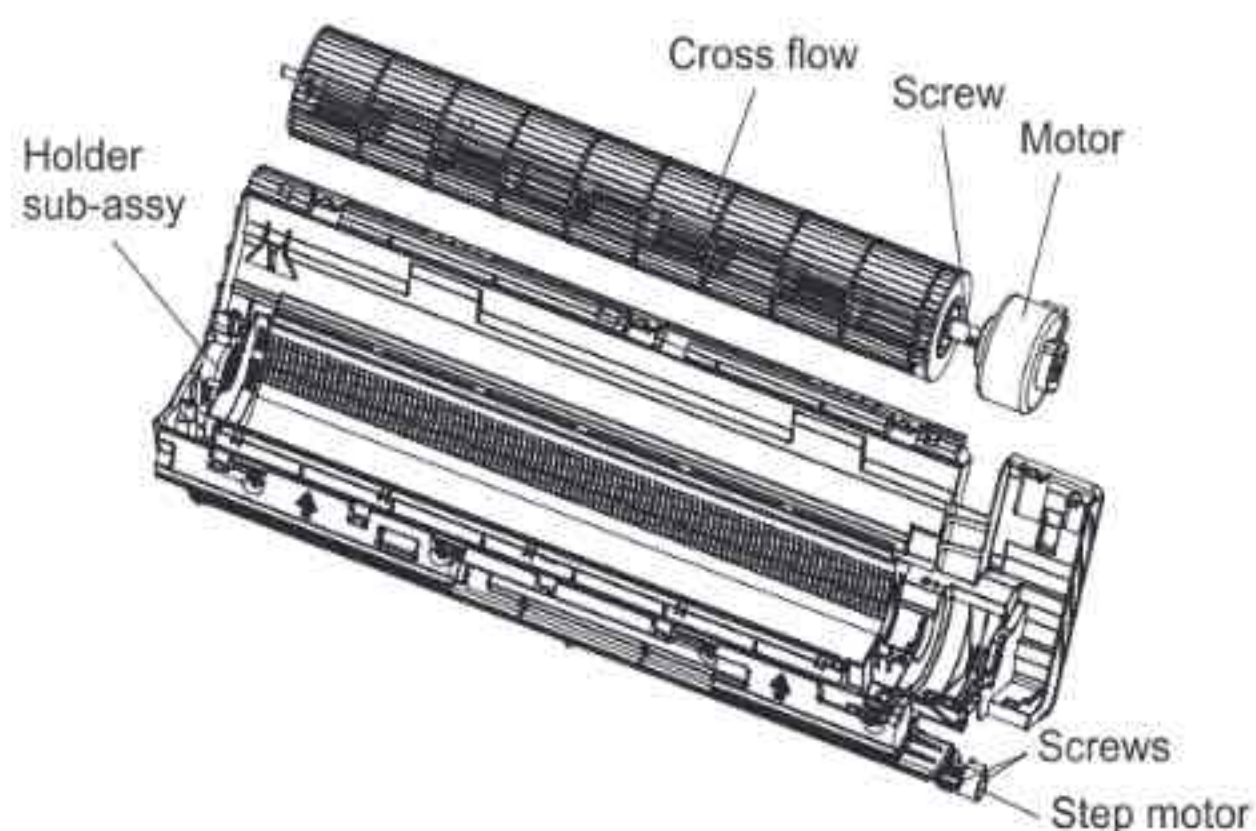
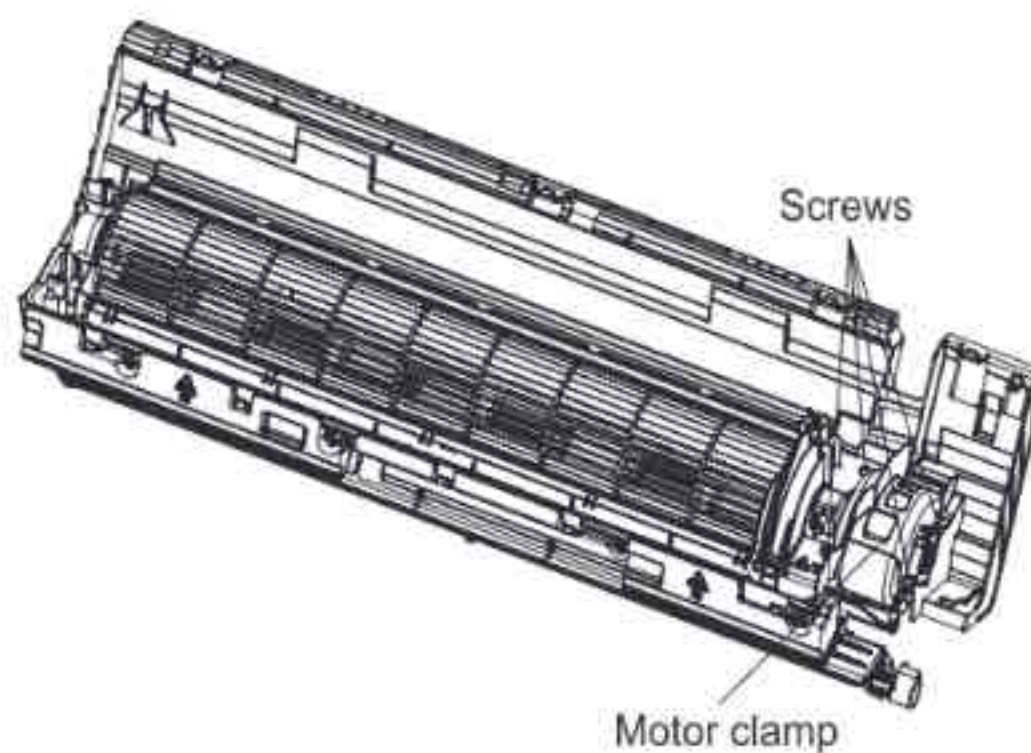

## 11.2 Removal Procedure of Outdoor Unit

**Warning:** Be sure to wait for a minimum of 20 minutes after turning off all power supplies and discharge the refrigerant completely before removal.

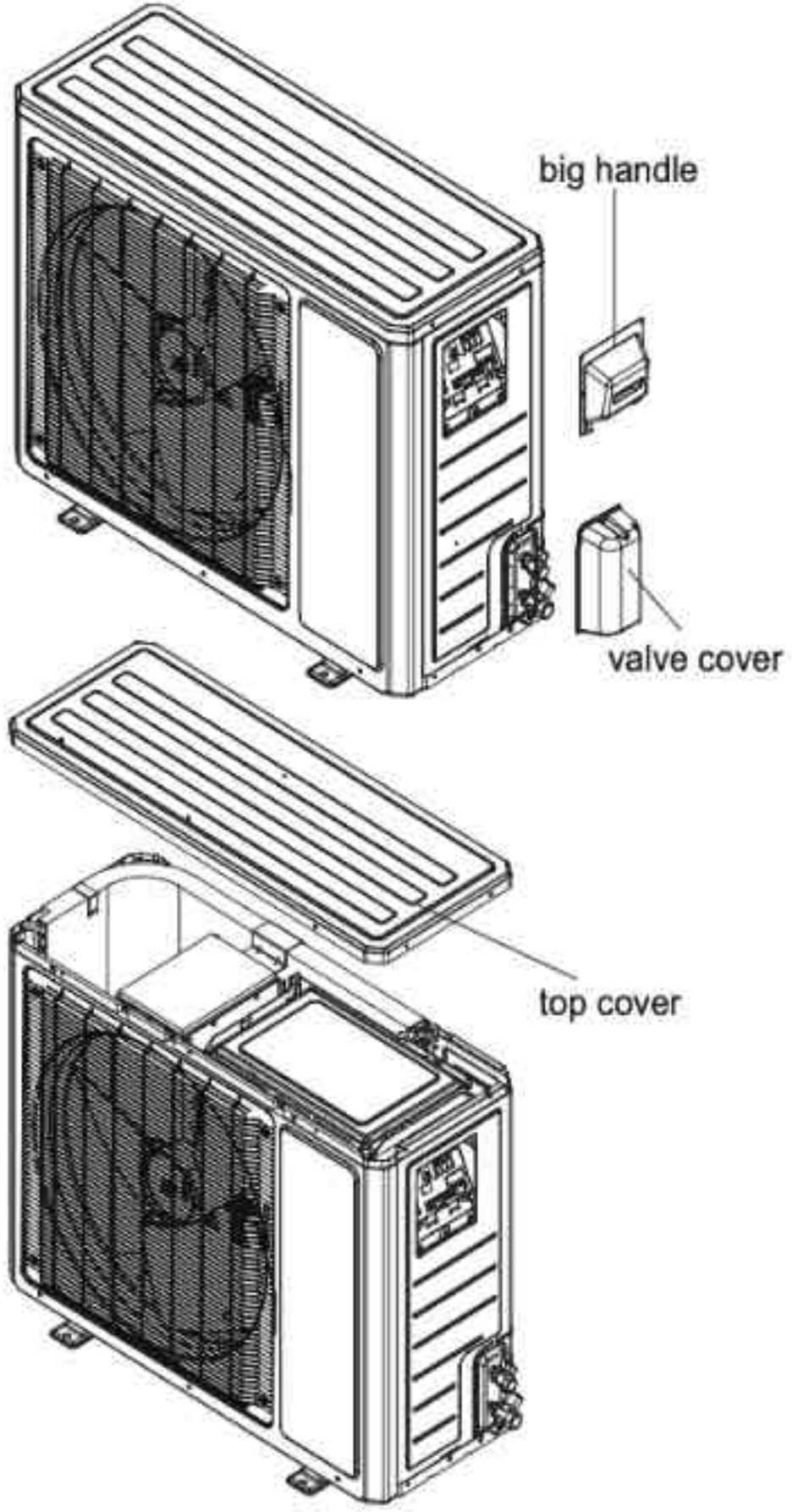
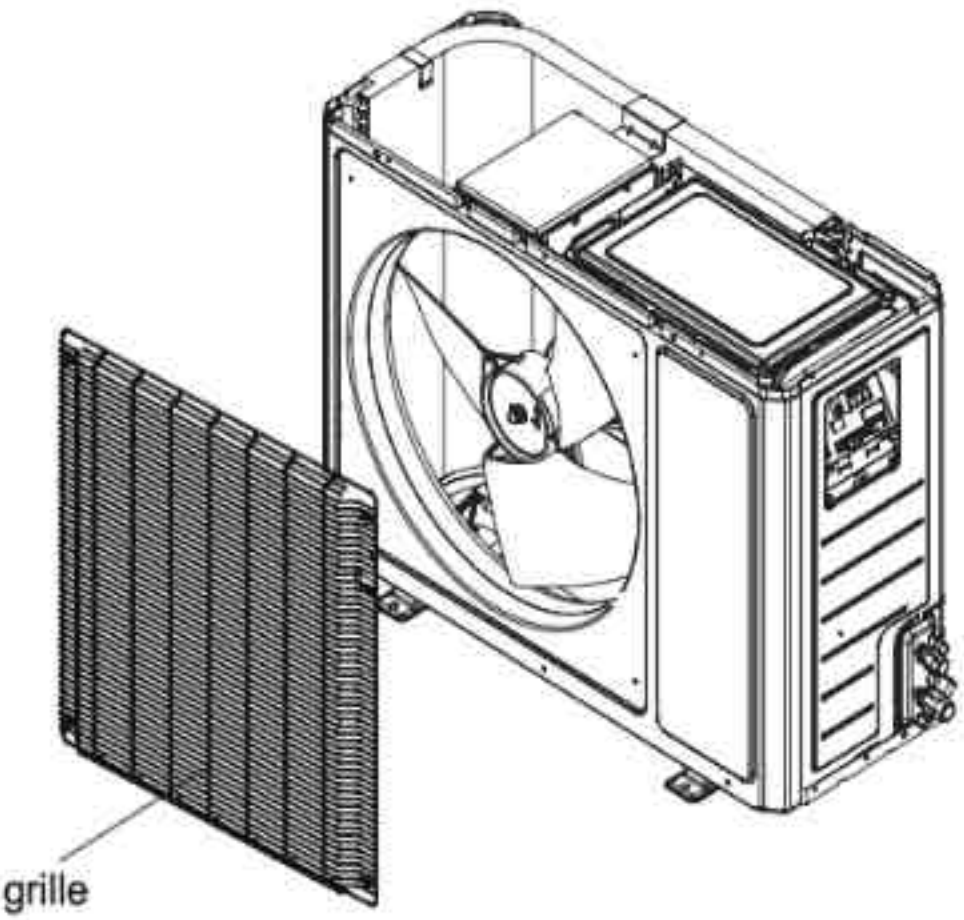
| Steps  | Procedure   |
|--|---|
| <p>1. Remove big handle, valve cover and top cover</p> <p>a</p> <p>b</p> | <p>Remove the screw connecting the big handle and right side plate, and then remove the big handle. Remove the screw connecting the valve cover and right side plate, and then remove the valve cover.</p> <p>Remove the screws connecting the top cover with outer case, right side plate and left side plate; lift the top cover upwards to remove it.</p>  <p>The diagram illustrates the removal of the top cover and handle. It shows the outdoor unit with the top cover being lifted off. Labels include 'big handle', 'valve cover', and 'top cover'.</p> |
| <p>2. Remove grille and outer case</p>                                   | <p>Remove the 4 screws connecting the grille and outer case, and then remove the panel grille.</p>  <p>The diagram shows the grille being removed from the front of the outdoor unit. A label 'grille' points to the removed panel.</p>  |

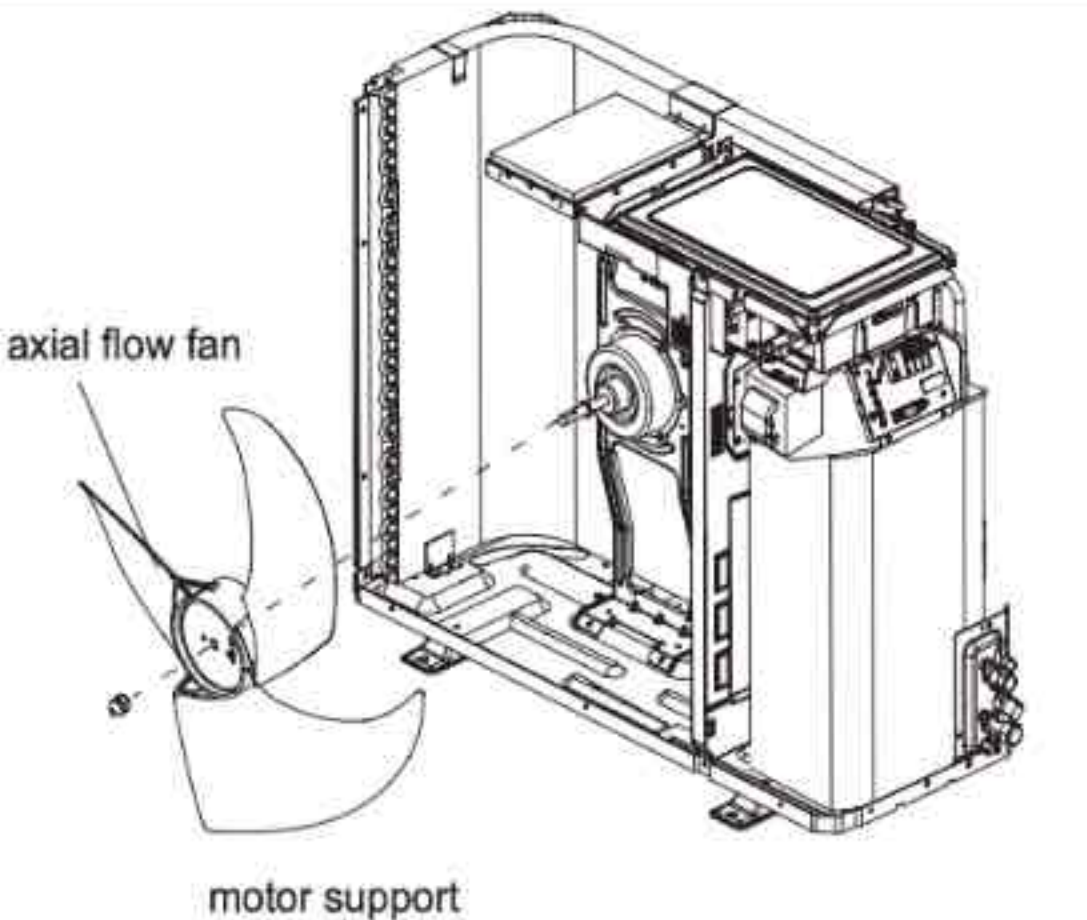
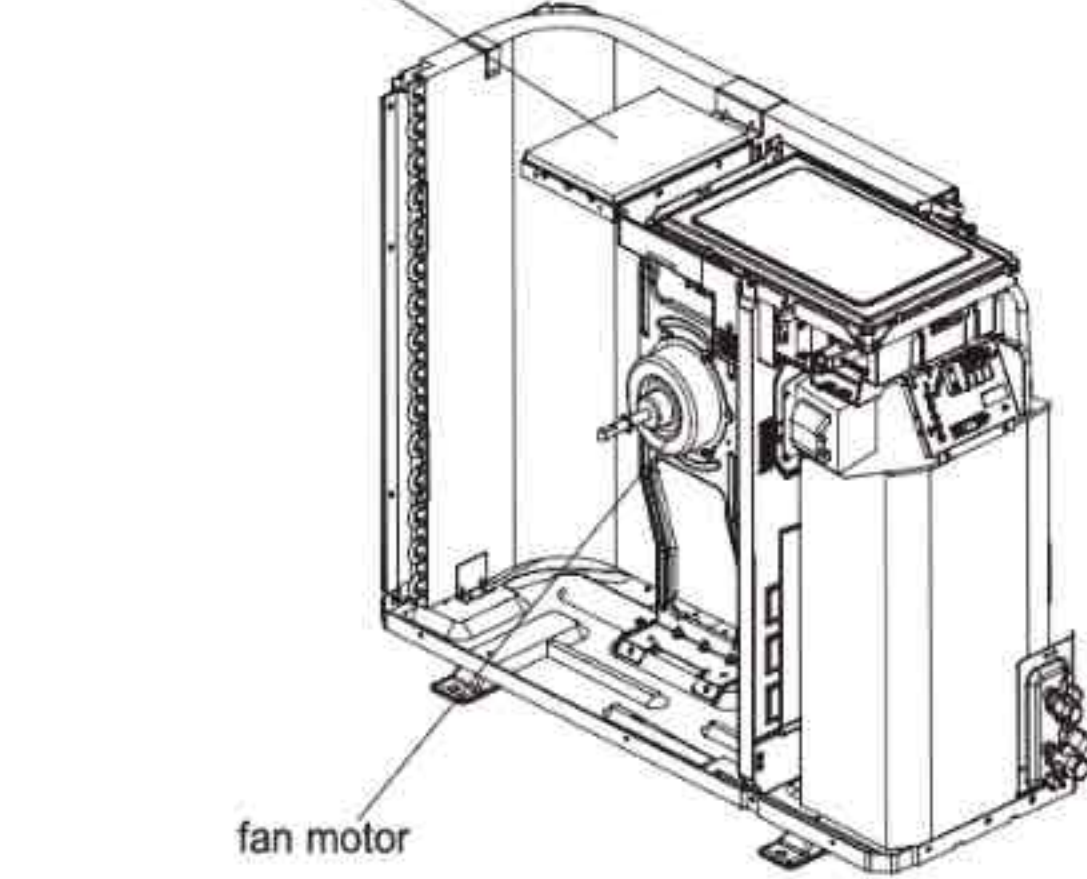
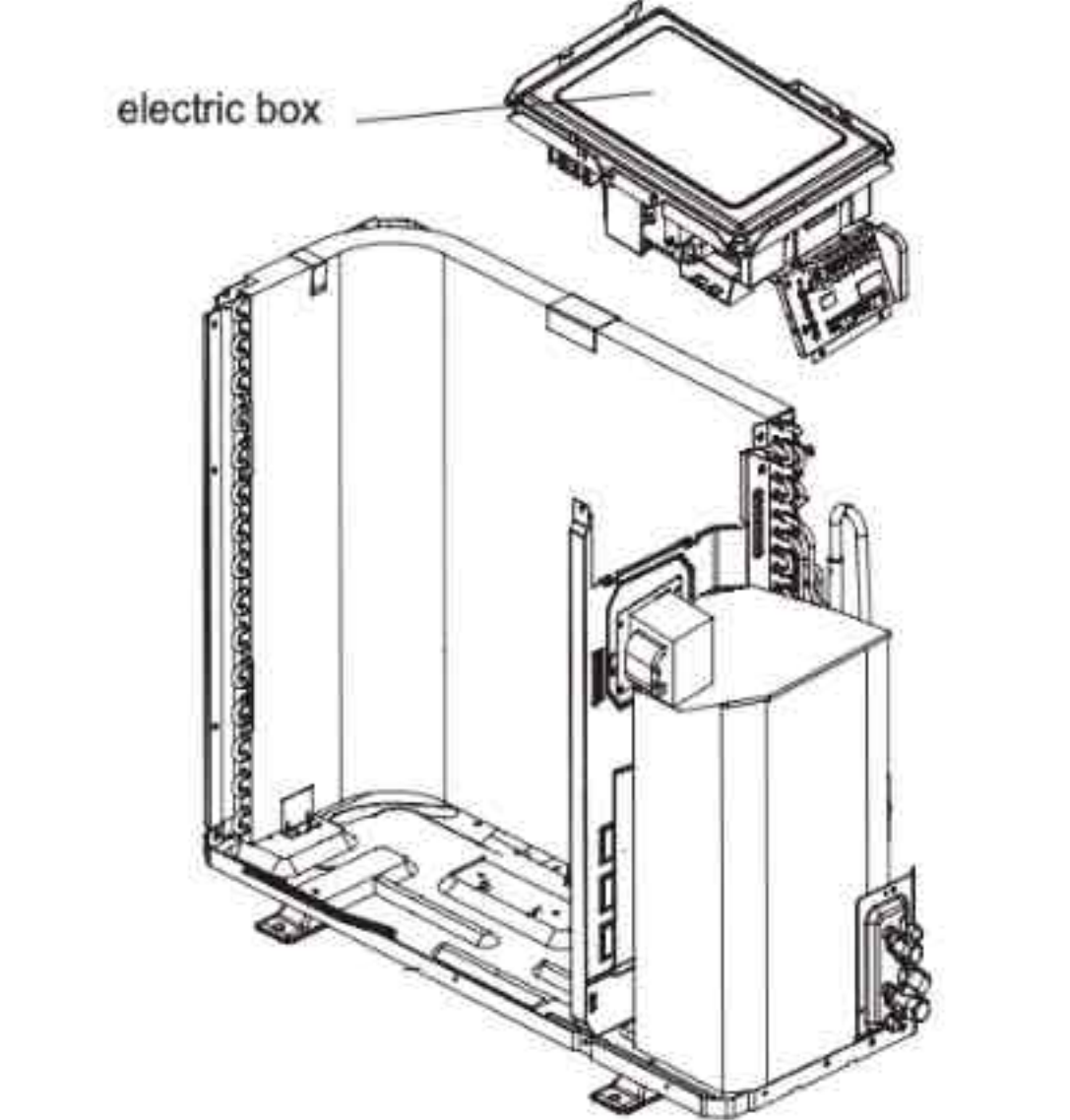

| Steps                      | Procedure  |   |
|----------------------------|--|---|
| 4. Remove axial flow blade |  |   |
| a                          | Remove the nut fixing axial flow blade and then remove the blade.  |  <p>axial flow fan</p> <p>motor support</p> |
| b                          | Remove the 6 screws fixing the motor and then remove the motor. Remove the 2 screws connecting the motor support and chassis, and then loosen the stopper to remove the motor support. |  <p>fan motor</p>                          |
| 5. Remove electric box     |  |   |
|                            | Remove the screws fixing the electric box sub-assy; loosen the wire bundle; pull out the wiring terminals and then pull the electric box upwards to remove it.                         |  <p>electric box</p>                       |

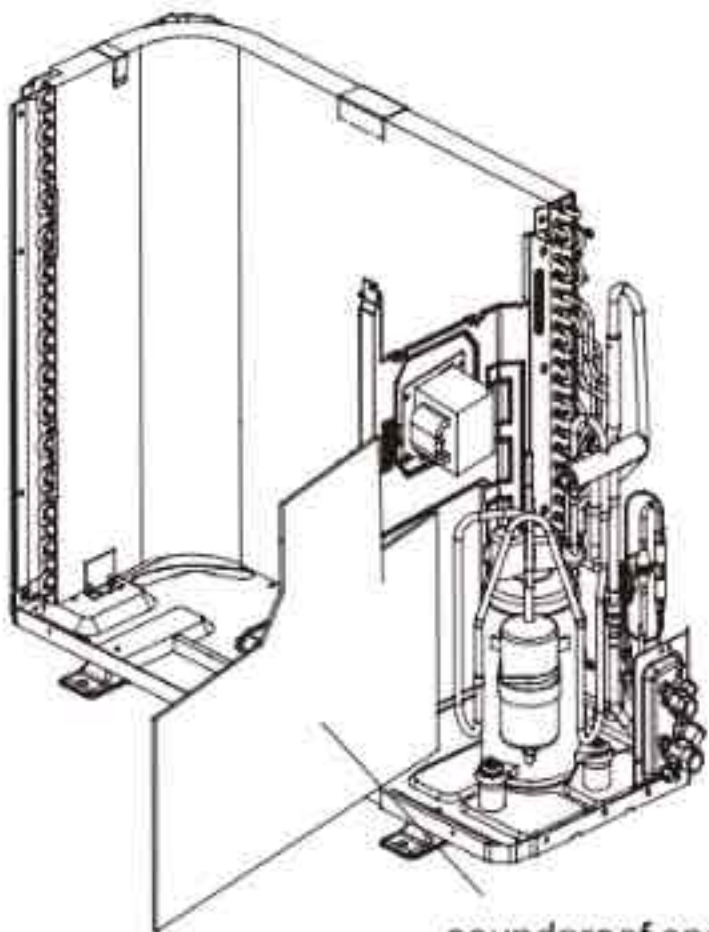
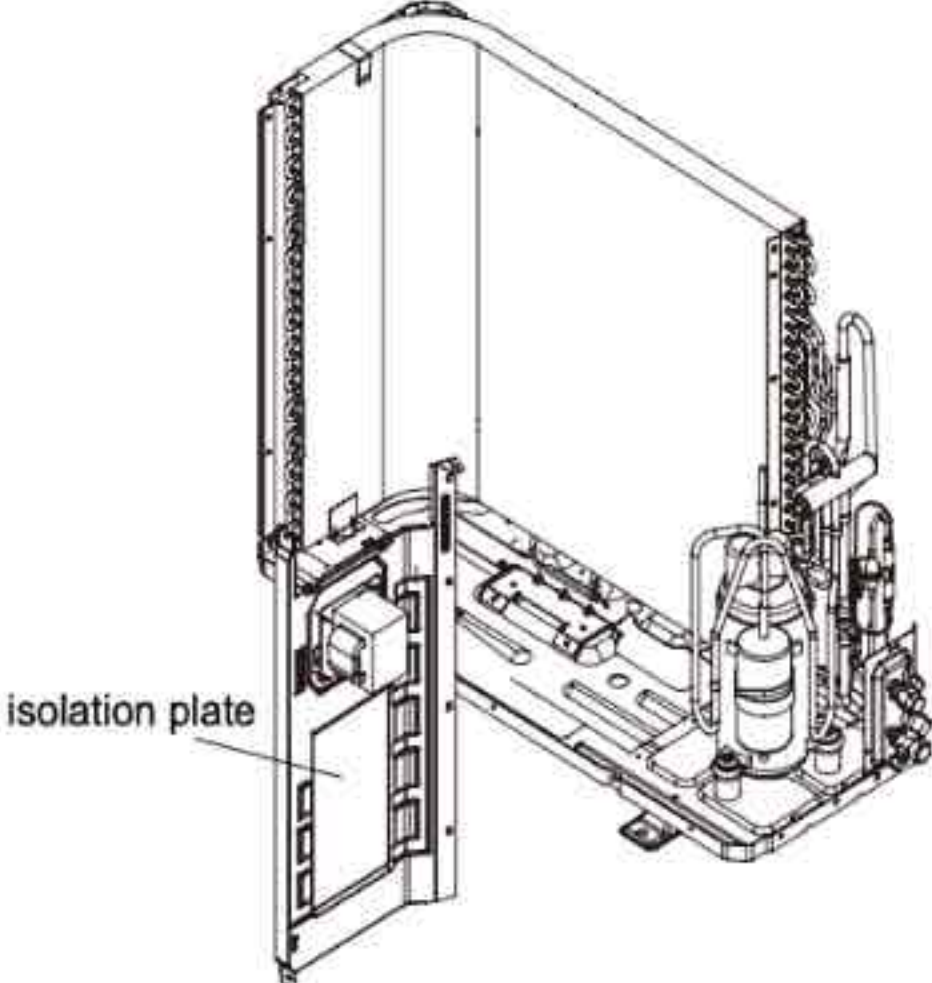
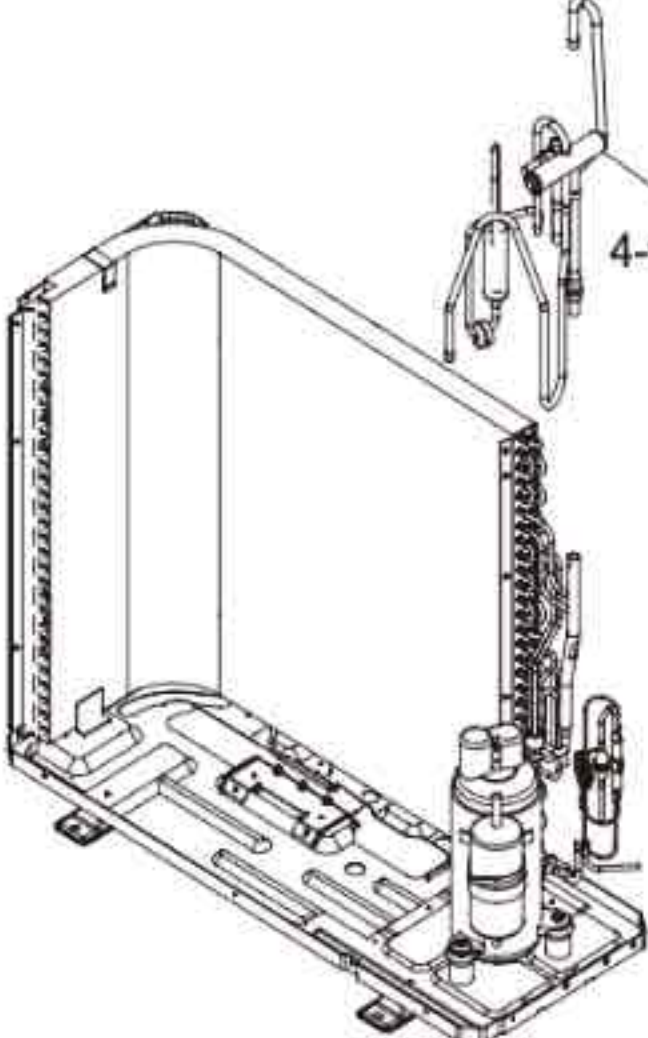
| Steps                           | Procedure   |  |
|---------------------------------|---|--|
| 6. Remove the soundproof sponge | Tear off the sticking stripe and then remove the soundproof sponge.   |  <p style="text-align: right;">soundproof sponge</p> |
| 7. Remove isolation plate       | Remove the 2 screws connecting the isolation plate and condenser side plate; remove the 3 screws connecting the isolation plate and chassis, and then remove the isolation plate.   |  <p style="text-align: left;">isolation plate</p>   |
| 8. Remove 4-way valve assy      | <p>Unsolder the welding joints connecting the 4-way valve assy with capillary sub-assy, compressor and condenser; remove the 4-way valve.</p> <p><b>Note:</b><br/>Before unsoldering the welding joint, wrap the 4-way valve with a wet cloth completely to avoid damage to the valve caused by high temperature.</p> |  <p style="text-align: right;">4-way valve assy</p> |

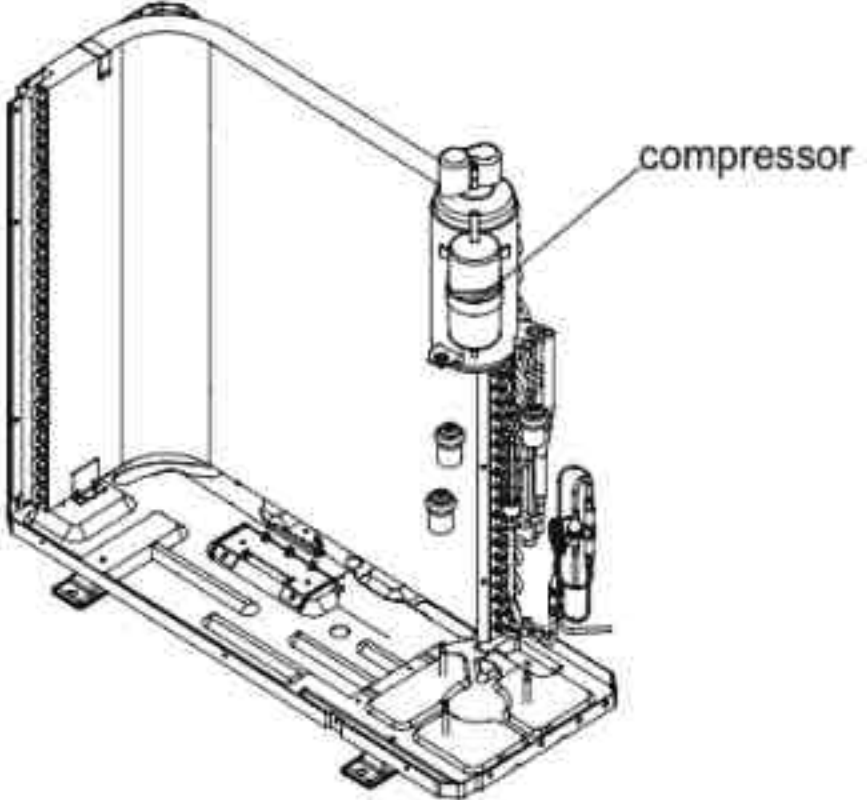
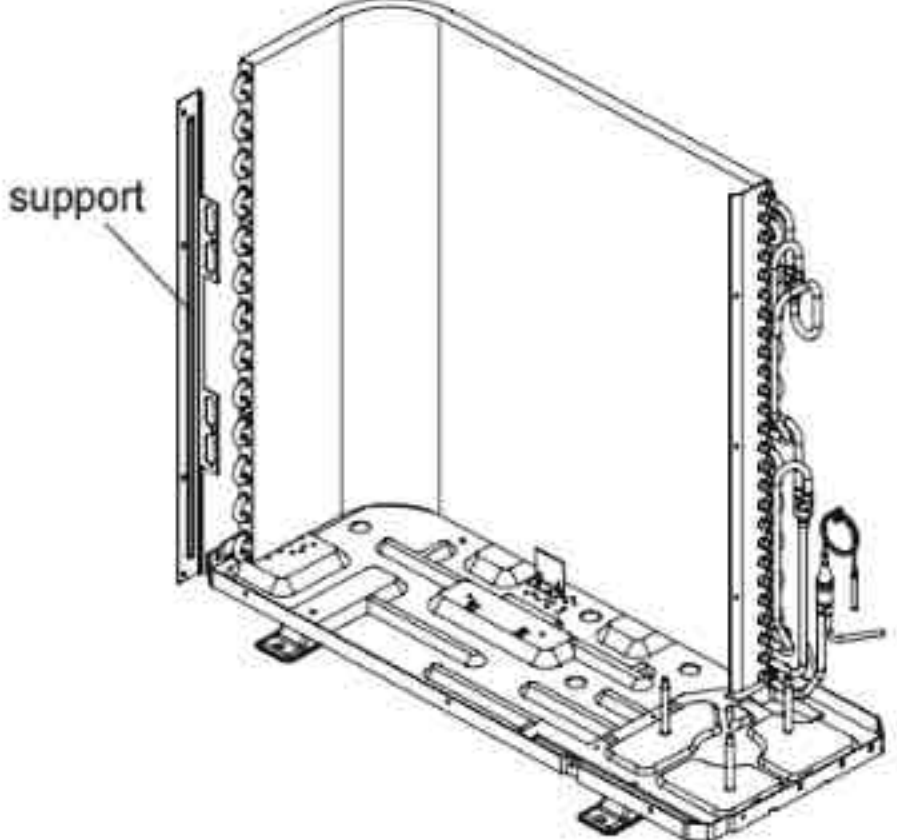
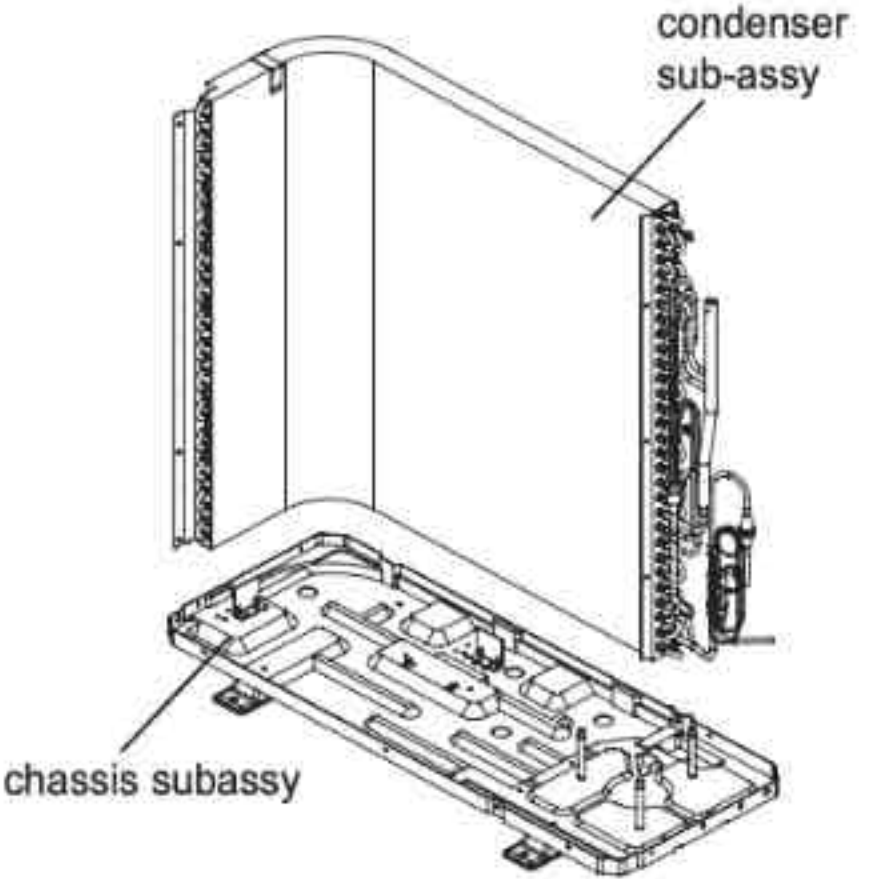
| Steps                         | Procedure   |   |
|-------------------------------|---|---|
| 9. Remove compressor          |   |   |
|                               | <p>Remove the 3 foot nuts fixing compressor and then lift the compressor upwards to remove the compressor and damping cushion.</p> <p>Note:<br/>Keep the ports of discharge pipe and suction pipe from foreign objects.</p> |  <p>A technical drawing showing the compressor being lifted upwards from the chassis sub-assembly. A label 'compressor' points to the cylindrical component being removed.</p>                            |
| 10. Remove condenser sub-assy |   |   |
| a                             | <p>Remove the screws connecting the support (condenser) and condenser assy, and then remove the support (condenser).</p>  |  <p>A technical drawing showing the condenser support being removed from the chassis sub-assembly. A label 'support' points to the vertical frame component.</p>   |
| b                             | <p>Remove the 2 screws fixing the condenser and chassis, and then lift the condenser upwards to remove it.</p>  |  <p>A technical drawing showing the condenser sub-assembly being lifted upwards from the chassis sub-assembly. Labels 'condenser sub-assy' and 'chassis subassy' point to the respective components.</p> |

## Appendix:

### Appendix 1: Reference Sheet of Celsius and Fahrenheit

Conversion formula for Fahrenheit degree and Celsius degree:  $T_f = T_c \times 1.8 + 32$

Set temperature

| Fahrenheit display temperature (°F) | Fahrenheit (°F) | Celsius (°C) | Fahrenheit display temperature (°F) | Fahrenheit (°F) | Celsius (°C) | Fahrenheit display temperature (°F) | Fahrenheit (°F) | Celsius (°C) |
|-------------------------------------|-----------------|--------------|-------------------------------------|-----------------|--------------|-------------------------------------|-----------------|--------------|
| 61                                  | 60.8            | 16           | 69/70                               | 69.8            | 21           | 78/79                               | 78.8            | 26           |
| 62/63                               | 62.6            | 17           | 71/72                               | 71.6            | 22           | 80/81                               | 80.6            | 27           |
| 64/65                               | 64.4            | 18           | 73/74                               | 73.4            | 23           | 82/83                               | 82.4            | 28           |
| 66/67                               | 66.2            | 19           | 75/76                               | 75.2            | 24           | 84/85                               | 84.2            | 29           |
| 68                                  | 68              | 20           | 77                                  | 77              | 25           | 86                                  | 86              | 30           |

Ambient temperature

| Fahrenheit display temperature (°F) | Fahrenheit (°F) | Celsius (°C) | Fahrenheit display temperature (°F) | Fahrenheit (°F) | Celsius (°C) | Fahrenheit display temperature (°F) | Fahrenheit (°F) | Celsius (°C) |
|-------------------------------------|-----------------|--------------|-------------------------------------|-----------------|--------------|-------------------------------------|-----------------|--------------|
| 32/33                               | 32              | 0            | 55/56                               | 55.4            | 13           | 79/80                               | 78.8            | 26           |
| 34/35                               | 33.8            | 1            | 57/58                               | 57.2            | 14           | 81                                  | 80.6            | 27           |
| 36                                  | 35.6            | 2            | 59/60                               | 59              | 15           | 82/83                               | 82.4            | 28           |
| 37/38                               | 37.4            | 3            | 61/62                               | 60.8            | 16           | 84/85                               | 84.2            | 29           |
| 39/40                               | 39.2            | 4            | 63                                  | 62.6            | 17           | 86/87                               | 86              | 30           |
| 41/42                               | 41              | 5            | 64/65                               | 64.4            | 18           | 88/89                               | 87.8            | 31           |
| 43/44                               | 42.8            | 6            | 66/67                               | 66.2            | 19           | 90                                  | 89.6            | 32           |
| 45                                  | 44.6            | 7            | 68/69                               | 68              | 20           | 91/92                               | 91.4            | 33           |
| 46/47                               | 46.4            | 8            | 70/71                               | 69.8            | 21           | 93/94                               | 93.2            | 34           |
| 48/49                               | 48.2            | 9            | 72                                  | 71.6            | 22           | 95/96                               | 95              | 35           |
| 50/51                               | 50              | 10           | 73/74                               | 73.4            | 23           | 97/98                               | 96.8            | 36           |
| 52/53                               | 51.8            | 11           | 75/76                               | 75.2            | 24           | 99                                  | 98.6            | 37           |
| 54                                  | 53.6            | 12           | 77/78                               | 77              | 25           |                                     |                 |              |

### Appendix 2: Configuration of Connection Pipe

- Standard length of connection pipe (More details please refer to the specifications)
- Min. length of connection pipe is 9.84ft.
- Max. length of connection pipe and max. high difference. (More details please refer to the specifications)
- The additional refrigerant oil and refrigerant charging required after prolonging connection pipe
  - After the length of connection pipe is prolonged for 32.81ft at the basis of standard length, you should add 5ml of refrigerant oil for each additional 16.40ft of connection pipe.
  - The calculation method of additional refrigerant charging amount (on the basis of liquid pipe):
  - Basing on the length of standard pipe, add refrigerant according to the requirement as shown in the table. The additional refrigerant charging amount per meter is different according to the diameter of liquid pipe. See the following sheet.
  - Additional refrigerant charging amount = prolonged length of liquid pipe X additional refrigerant charging amount per meter

| Additional refrigerant charging amount for R22, R407C, R410A and R134a |                 |                        |                               |
|--|-----------------|------------------------|-------------------------------|
| Diameter of connection pipe  |                 | Outdoor unit throttle  |                               |
| Liquid pipe (inch)   | Gas pipe (inch) | Cooling only (oz./ft.) | Cooling and heating (oz./ft.) |
| Φ0.24  | Φ0.37 or Φ0.47  | 0.2                    | 0.2                           |
| Φ0.24 or Φ0.37   | Φ0.63 or Φ0.75  | 0.2                    | 0.6                           |
| Φ0.47  | Φ0.75 or Φ0.87  | 0.3                    | 1.3                           |
| Φ0.63  | Φ1 or Φ1.25     | 0.7                    | 1.3                           |
| Φ0.75  | /               | 2.7                    | 2.7                           |
| Φ0.87  | /               | 3.8                    | 3.8                           |

## Appendix 3: Pipe Expanding Method

**⚠ Note:**

Improper pipe expanding is the main cause of refrigerant leakage. Please expand the pipe according to the following steps:

**A: Cut the pipe**

- Confirm the pipe length according to the distance of indoor unit and outdoor unit.
- Cut the required pipe with pipe cutter.

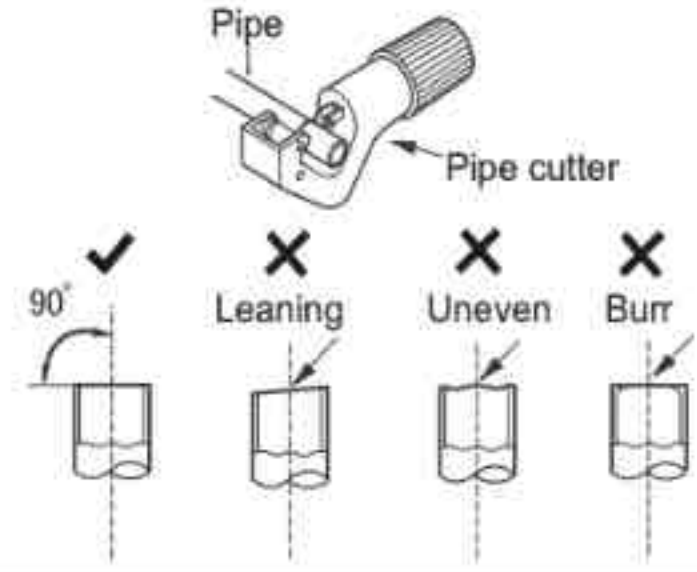

**B: Remove the burrs**

- Remove the burrs with shaper and prevent the burrs from getting into the pipe.

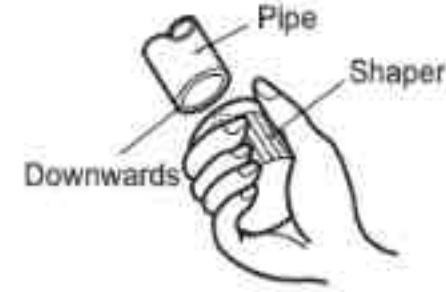

**C: Put on suitable insulating pipe**

**D: Put on the union nut**

- Remove the union nut on the indoor connection pipe and outdoor valve; install the union nut on the pipe.

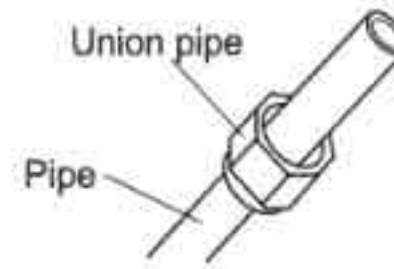

**E: Expand the port**

- Expand the port with expander.

**⚠ Note:**

- "A" is different according to the diameter, please refer to the sheet below:

| Outer diameter(inch) | A(inch) |      |
|----------------------|---------|------|
|                      | Max     | Min  |
| Φ1/4                 | 2/39    | 1/36 |
| Φ3/8                 | 1/16    | 1/51 |
| Φ1/2                 | 1/14    | 1/51 |
| Φ5/8                 | 5/53    | 2/23 |

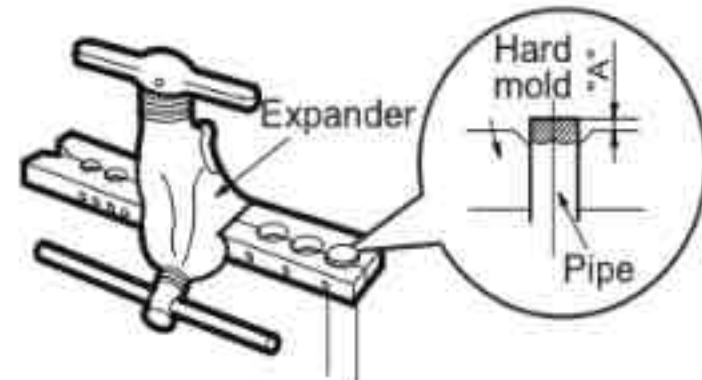

**F: Inspection**

- Check the quality of expanding port. If there is any blemish, expand the port again according to the steps above.

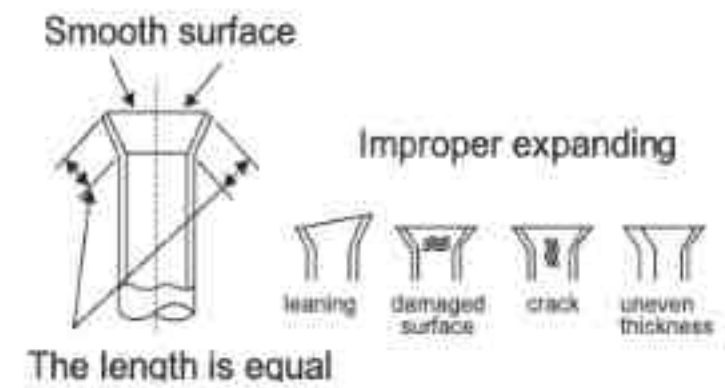

## Appendix 4: List of Resistance for Temperature Sensor

Resistance Table of Ambient Temperature Sensor for Indoor and Outdoor Units(15K)

| Temp.(°F) | Resistance(kΩ) | Temp.(°F) | Resistance(kΩ) | Temp.(°F) | Resistance(kΩ) | Temp.(°F) | Resistance(kΩ) |
|-----------|----------------|-----------|----------------|-----------|----------------|-----------|----------------|
| -2.2      | 138.1          | 68        | 18.75          | 138.2     | 3.848          | 208.4     | 1.071          |
| -0.4      | 128.6          | 69.8      | 17.93          | 140       | 3.711          | 210.2     | 1.039          |
| 1.4       | 121.6          | 71.6      | 17.14          | 141.8     | 3.579          | 212       | 1.009          |
| 3.2       | 115            | 73.4      | 16.39          | 143.6     | 3.454          | 213.8     | 0.98           |
| 5         | 108.7          | 75.2      | 15.68          | 145.4     | 3.333          | 215.6     | 0.952          |
| 6.8       | 102.9          | 77        | 15             | 147.2     | 3.217          | 217.4     | 0.925          |
| 8.6       | 97.4           | 78.8      | 14.36          | 149       | 3.105          | 219.2     | 0.898          |
| 10.4      | 92.22          | 80.6      | 13.74          | 150.8     | 2.998          | 221       | 0.873          |
| 12.2      | 87.35          | 82.4      | 13.16          | 152.6     | 2.896          | 222.8     | 0.848          |
| 14        | 82.75          | 84.2      | 12.6           | 154.4     | 2.797          | 224.6     | 0.825          |
| 15.8      | 78.43          | 86        | 12.07          | 156.2     | 2.702          | 226.4     | 0.802          |
| 17.6      | 74.35          | 87.8      | 11.57          | 158       | 2.611          | 228.2     | 0.779          |
| 19.4      | 70.5           | 89.6      | 11.09          | 159.8     | 2.523          | 230       | 0.758          |
| 21.2      | 66.88          | 91.4      | 10.63          | 161.6     | 2.439          | 231.8     | 0.737          |
| 23        | 63.46          | 93.2      | 10.2           | 163.4     | 2.358          | 233.6     | 0.717          |
| 24.8      | 60.23          | 95        | 9.779          | 165.2     | 2.28           | 235.4     | 0.697          |
| 26.6      | 57.18          | 96.8      | 9.382          | 167       | 2.206          | 237.2     | 0.678          |
| 28.4      | 54.31          | 98.6      | 9.003          | 168.8     | 2.133          | 239       | 0.66           |
| 30.2      | 51.59          | 100.4     | 8.642          | 170.6     | 2.064          | 240.8     | 0.642          |
| 32        | 49.02          | 102.2     | 8.297          | 172.4     | 1.997          | 242.6     | 0.625          |
| 33.8      | 46.6           | 104       | 7.967          | 174.2     | 1.933          | 244.4     | 0.608          |
| 35.6      | 44.31          | 105.8     | 7.653          | 176       | 1.871          | 246.2     | 0.592          |
| 37.4      | 42.14          | 107.6     | 7.352          | 177.8     | 1.811          | 248       | 0.577          |
| 39.2      | 40.09          | 109.4     | 7.065          | 179.6     | 1.754          | 249.8     | 0.561          |
| 41        | 38.15          | 111.2     | 6.791          | 181.4     | 1.699          | 251.6     | 0.547          |
| 42.8      | 36.32          | 113       | 6.529          | 183.2     | 1.645          | 253.4     | 0.532          |
| 44.6      | 34.58          | 114.8     | 6.278          | 185       | 1.594          | 255.2     | 0.519          |
| 46.4      | 32.94          | 116.6     | 6.038          | 186.8     | 1.544          | 257       | 0.505          |
| 48.2      | 31.38          | 118.4     | 5.809          | 188.6     | 1.497          | 258.8     | 0.492          |
| 50        | 29.9           | 120.2     | 5.589          | 190.4     | 1.451          | 260.6     | 0.48           |
| 51.8      | 28.51          | 122       | 5.379          | 192.2     | 1.408          | 262.4     | 0.467          |
| 53.6      | 27.18          | 123.8     | 5.197          | 194       | 1.363          | 264.2     | 0.456          |
| 55.4      | 25.92          | 125.6     | 4.986          | 195.8     | 1.322          | 266       | 0.444          |
| 57.2      | 24.73          | 127.4     | 4.802          | 197.6     | 1.282          | 267.8     | 0.433          |
| 59        | 23.6           | 129.2     | 4.625          | 199.4     | 1.244          | 269.6     | 0.422          |
| 60.8      | 22.53          | 131       | 4.456          | 201.2     | 1.207          | 271.4     | 0.412          |
| 62.6      | 21.51          | 132.8     | 4.294          | 203       | 1.171          | 273.2     | 0.401          |
| 64.4      | 20.54          | 134.6     | 4.139          | 204.8     | 1.136          | 275       | 0.391          |
| 66.2      | 19.63          | 136.4     | 3.99           | 206.6     | 1.103          | 276.8     | 0.382          |

Resistance Table of Tube Temperature Sensors for Indoor and Outdoor (20K)

| Temp.(°F) | Resistance(kΩ) | Temp.(°F) | Resistance(kΩ) | Temp.(°F) | Resistance(kΩ) | Temp.(°F) | Resistance(kΩ) |
|-----------|----------------|-----------|----------------|-----------|----------------|-----------|----------------|
| -2.2      | 181.4          | 68        | 25.01          | 138.2     | 5.13           | 208.4     | 1.427          |
| -0.4      | 171.4          | 69.8      | 23.9           | 140       | 4.948          | 210.2     | 1.386          |
| 1.4       | 162.1          | 71.6      | 22.85          | 141.8     | 4.773          | 212       | 1.346          |
| 3.2       | 153.3          | 73.4      | 21.85          | 143.6     | 4.605          | 213.8     | 1.307          |
| 5         | 145            | 75.2      | 20.9           | 145.4     | 4.443          | 215.6     | 1.269          |
| 6.8       | 137.2          | 77        | 20             | 147.2     | 4.289          | 217.4     | 1.233          |
| 8.6       | 129.9          | 78.8      | 19.14          | 149       | 4.14           | 219.2     | 1.198          |
| 10.4      | 123            | 80.6      | 18.13          | 150.8     | 3.998          | 221       | 1.164          |
| 12.2      | 116.5          | 82.4      | 17.55          | 152.6     | 3.861          | 222.8     | 1.131          |
| 14        | 110.3          | 84.2      | 16.8           | 154.4     | 3.729          | 224.6     | 1.099          |
| 15.8      | 104.6          | 86        | 16.1           | 156.2     | 3.603          | 226.4     | 1.069          |
| 17.6      | 99.13          | 87.8      | 15.43          | 158       | 3.481          | 228.2     | 1.039          |
| 19.4      | 94             | 89.6      | 14.79          | 159.8     | 3.364          | 230       | 1.01           |
| 21.2      | 89.17          | 91.4      | 14.18          | 161.6     | 3.252          | 231.8     | 0.983          |
| 23        | 84.61          | 93.2      | 13.59          | 163.4     | 3.144          | 233.6     | 0.956          |
| 24.8      | 80.31          | 95        | 13.04          | 165.2     | 3.04           | 235.4     | 0.93           |
| 26.6      | 76.24          | 96.8      | 12.51          | 167       | 2.94           | 237.2     | 0.904          |
| 28.4      | 72.41          | 98.6      | 12             | 168.8     | 2.844          | 239       | 0.88           |
| 30.2      | 68.79          | 100.4     | 11.52          | 170.6     | 2.752          | 240.8     | 0.856          |
| 32        | 65.37          | 102.2     | 11.06          | 172.4     | 2.663          | 242.6     | 0.833          |
| 33.8      | 62.13          | 104       | 10.62          | 174.2     | 2.577          | 244.4     | 0.811          |
| 35.6      | 59.08          | 105.8     | 10.2           | 176       | 2.495          | 246.2     | 0.77           |
| 37.4      | 56.19          | 107.6     | 9.803          | 177.8     | 2.415          | 248       | 0.769          |
| 39.2      | 53.46          | 109.4     | 9.42           | 179.6     | 2.339          | 249.8     | 0.746          |
| 41        | 50.87          | 111.2     | 9.054          | 181.4     | 2.265          | 251.6     | 0.729          |
| 42.8      | 48.42          | 113       | 8.705          | 183.2     | 2.194          | 253.4     | 0.71           |
| 44.6      | 46.11          | 114.8     | 8.37           | 185       | 2.125          | 255.2     | 0.692          |
| 46.4      | 43.92          | 116.6     | 8.051          | 186.8     | 2.059          | 257       | 0.674          |
| 48.2      | 41.84          | 118.4     | 7.745          | 188.6     | 1.996          | 258.8     | 0.658          |
| 50        | 39.87          | 120.2     | 7.453          | 190.4     | 1.934          | 260.6     | 0.64           |
| 51.8      | 38.01          | 122       | 7.173          | 192.2     | 1.875          | 262.4     | 0.623          |
| 53.6      | 36.24          | 123.8     | 6.905          | 194       | 1.818          | 264.2     | 0.607          |
| 55.4      | 34.57          | 125.6     | 6.648          | 195.8     | 1.736          | 266       | 0.592          |
| 57.2      | 32.98          | 127.4     | 6.403          | 197.6     | 1.71           | 267.8     | 0.577          |
| 59        | 31.47          | 129.2     | 6.167          | 199.4     | 1.658          | 269.6     | 0.563          |
| 60.8      | 30.04          | 131       | 5.942          | 201.2     | 1.609          | 271.4     | 0.549          |
| 62.6      | 28.68          | 132.8     | 5.726          | 203       | 1.561          | 273.2     | 0.535          |
| 64.4      | 27.39          | 134.6     | 5.519          | 204.8     | 1.515          | 275       | 0.521          |
| 66.2      | 26.17          | 136.4     | 5.32           | 206.6     | 1.47           | 276.8     | 0.509          |

Resistance Table of Discharge Temperature Sensor for Outdoor(50K)

| Temp.(°F) | Resistance(kΩ) | Temp.(°F) | Resistance(kΩ) | Temp.(°F) | Resistance(kΩ) | Temp.(°F) | Resistance(kΩ) |
|-----------|----------------|-----------|----------------|-----------|----------------|-----------|----------------|
| -20.2     | 853.5          | 50        | 98             | 120.2     | 18.34          | 190.4     | 4.754          |
| -18.4     | 799.8          | 51.8      | 93.42          | 122       | 17.65          | 192.2     | 4.609          |
| -16.6     | 750            | 53.6      | 89.07          | 123.8     | 16.99          | 194       | 4.469          |
| -14.8     | 703.8          | 55.4      | 84.95          | 125.6     | 16.36          | 195.8     | 4.334          |
| -13       | 660.8          | 57.2      | 81.05          | 127.4     | 15.75          | 197.6     | 4.204          |
| -11.2     | 620.8          | 59        | 77.35          | 129.2     | 15.17          | 199.4     | 4.079          |
| -9.4      | 580.6          | 60.8      | 73.83          | 131       | 14.62          | 201.2     | 3.958          |
| -7.6      | 548.9          | 62.6      | 70.5           | 132.8     | 14.09          | 203       | 3.841          |
| -5.8      | 516.6          | 64.4      | 67.34          | 134.6     | 13.58          | 204.8     | 3.728          |
| -4        | 486.5          | 66.2      | 64.33          | 136.4     | 13.09          | 206.6     | 3.619          |
| -2.2      | 458.3          | 68        | 61.48          | 138.2     | 12.62          | 208.4     | 3.514          |
| -0.4      | 432            | 69.8      | 58.77          | 140       | 12.17          | 210.2     | 3.413          |
| 1.4       | 407.4          | 71.6      | 56.19          | 141.8     | 11.74          | 212       | 3.315          |
| 3.2       | 384.5          | 73.4      | 53.74          | 143.6     | 11.32          | 213.8     | 3.22           |
| 5         | 362.9          | 75.2      | 51.41          | 145.4     | 10.93          | 215.6     | 3.129          |
| 6.8       | 342.8          | 77        | 49.19          | 147.2     | 10.54          | 217.4     | 3.04           |
| 8.6       | 323.9          | 78.8      | 47.08          | 149       | 10.18          | 219.2     | 2.955          |
| 10.4      | 306.2          | 80.6      | 45.07          | 150.8     | 9.827          | 221       | 2.872          |
| 12.2      | 289.6          | 82.4      | 43.16          | 152.6     | 9.489          | 222.8     | 2.792          |
| 14        | 274            | 84.2      | 41.34          | 154.4     | 9.165          | 224.6     | 2.715          |
| 15.8      | 259.3          | 86        | 39.61          | 156.2     | 8.854          | 226.4     | 2.64           |
| 17.6      | 245.6          | 87.8      | 37.96          | 158       | 8.555          | 228.2     | 2.568          |
| 19.4      | 232.6          | 89.6      | 36.38          | 159.8     | 8.268          | 230       | 2.498          |
| 21.2      | 220.5          | 91.4      | 34.88          | 161.6     | 7.991          | 231.8     | 2.431          |
| 23        | 209            | 93.2      | 33.45          | 163.4     | 7.726          | 233.6     | 2.365          |
| 24.8      | 198.3          | 95        | 32.09          | 165.2     | 7.47           | 235.4     | 2.302          |
| 26.6      | 199.1          | 96.8      | 30.79          | 167       | 7.224          | 237.2     | 2.241          |
| 28.4      | 178.5          | 98.6      | 29.54          | 168.8     | 6.998          | 239       | 2.182          |
| 30.2      | 169.5          | 100.4     | 28.36          | 170.6     | 6.761          | 240.8     | 2.124          |
| 32        | 161            | 102.2     | 27.23          | 172.4     | 6.542          | 242.6     | 2.069          |
| 33.8      | 153            | 104       | 26.15          | 174.2     | 6.331          | 244.4     | 2.015          |
| 35.6      | 145.4          | 105.8     | 25.11          | 176       | 6.129          | 246.2     | 1.963          |
| 37.4      | 138.3          | 107.6     | 24.13          | 177.8     | 5.933          | 248       | 1.912          |
| 39.2      | 131.5          | 109.4     | 23.19          | 179.6     | 5.746          | 249.8     | 1.863          |
| 41        | 125.1          | 111.2     | 22.29          | 181.4     | 5.565          | 251.6     | 1.816          |
| 42.8      | 119.1          | 113       | 21.43          | 183.2     | 5.39           | 253.4     | 1.77           |
| 44.6      | 113.4          | 114.8     | 20.6           | 185       | 5.222          | 255.2     | 1.725          |
| 46.4      | 108            | 116.6     | 19.81          | 186.8     | 5.06           | 257       | 1.682          |
| 48.2      | 102.8          | 118.4     | 19.06          | 188.6     | 4.904          | 258.8     | 1.64           |



JF00302679

