



PV Module Installation Manual

Huansheng Photovoltaic reserves the right to change this manual without prior notice.

Applicable module models		Structure of modules
HSM-BD78-GFxxx*	HSM-BD54-GAxxx	Double glass photovoltaic modules xxx – Refers to the power rating
HSM-BD60-GAxxx	HSM-BD60-DAxxx	
HSM-BD72-DFxxx	HSM-BD72-GCxxx	
HSM-BD54-DAxxx	HSM-BD72-WCxxx	
HSM-BD60-GCxxx	HSM-BD54-GCxxx	
HSM-BD66-GRxxx	HSM-BE78-GAxxx	
HSM-BE72-GAxxx	HSM-BE60-GAxxx	
HSM-BE60-GCxxx	HSM-BE54-GCxxx	
HSM-BE60-DCxxx	HSM-BE54-DCxxx	
HSM-BE72-GDxxx	HSM-BE60-GDxxx	
HSM-BE54-GDxxx	HSM-BD54-LAxxx	
HSM-BD60-LAxxx	HSM-BD54-WAxxx	
HSM-ND66-GRxxx	HSM-ND66-GKxxx	
HSM-BD72-GFxxx		



Important Safety Information

- This installation manual provides information on the installation and safe use of photovoltaic modules (hereinafter referred to as "Modules") from Huansheng Photovoltaic((Jiangsu) Co., Ltd. (hereinafter referred to as "Huansheng Photovoltaic "). During module installation and routine maintenance, please comply with all safety precautions and local laws and regulations specified in this manual.
- Professional skills and knowledge are required to install and maintain module systems. Only qualified personnel can install and maintain module systems. Installation personnel should be familiar with the mechanical and

electrical requirements of the system. Please keep this manual for future maintenance or treatment.

Contents

1. Overview.....	4
2. Regulation and rules.....	4
3. General information.....	5
3.1 Module identification.....	5
3.2 Wiring mode.....	5
3.3 General safety.....	6
3.4 Electrical safety.....	7
3.5 Operational safety.....	8
3.6 Fire safety.....	9
4. Installation conditions.....	10
4.1 Installation site and working environment.....	10
4.2 Inclination angle selection.....	11
5. Mechanical installation.....	12
5.1 General requirements.....	12
5.2 Mechanical installation for double glass module.....	13
6. Electrical installation.....	19
6.1 Electrical performance.....	19
6.2 Cables and wiring.....	20
6.3 Connectors.....	20
7. Grounding.....	29
8. PV module maintenance.....	30
8.1 Clean.....	30
8.2 Visual inspection.....	30
8.3 Connector and cable inspection.....	31
9. Revision version and date.....	31
Product information.....	31

1. Overview

First of all, thank you for choosing HUANSHENG PHOTOVOLTAIC 's products. This installation manual contains important electrical and mechanical installation information. Please understand this information before you install modules. In addition, the manual also contains some other safety information that you must be familiar with.

This installation manual does not have the meaning of any warranty, whether express or implied. There is no provision on the compensation scheme for the loss, module damage or other expenses directly caused by or related to the installation, operation, use or maintenance of modules. If the patent right or the rights of a third party are infringed due to the use of modules, HUANSHENG PHOTOVOLTAIC will not bear any relevant responsibilities. HUANSHENG PHOTOVOLTAIC reserves the right to change the product manual and this installation manual without prior notice.

If the customer fails to follow the requirements listed in this manual during the installation of modules, the limited warranty provided to the customer will be invalid. At the same time, the recommendations in this manual are to improve the safety of modules during installation and have been tested and verified by practice. Please provide this manual to the owners of photovoltaic system for reference, and inform them of all relevant safety, operation and maintenance requirements and suggestions.

2. Regulation and rules

The mechanical installation and electrical installation of PV modules shall refer to corresponding regulations, including electrical law, building law and power connection requirements. These regulations vary from installation site to installation site, such as building roof installation, vehicle mounted applications, etc. Requirements may also vary depending on the voltage and current nature (DC or AC) of the installed system. Please contact the local authority for specific terms.

3. General information

3.1 Module identification

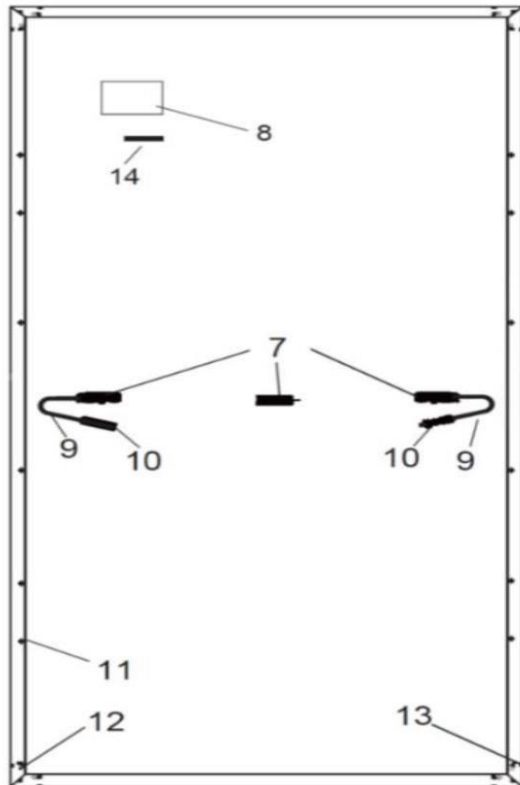

Double glass module structure diagram and component description

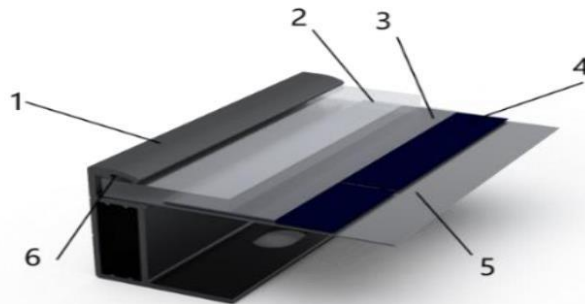

- | | |
|----------------------------|--------------------------|
| 1 Aluminium alloy frame | 8 Nameplate |
| 2 Front photovoltaic glass | 9 Electric cable |
| 3 Film | 10 Connector |
| 4 ABC cell | 11 Mounting hole |
| 5 Back photovoltaic glass | 12 Ground grounding hole |
| 6 Silicon | 13 Water leakage hole |
| 7 Junction box | 14 Barcode |

Three kinds of visual labels provided by HUANSHENG PHOTOVOLTAIC 's modules:

Nameplate: Product type, rated power under standard test conditions (STC), rated current, rated voltage, open circuit voltage, short circuit current under STC, certification mark, maximum system voltage and other information. **The nameplate and junction box is on the back of the module.**



Serial number: Each module has a unique serial number. This serial number is printed on the bar code and placed in the assembly before lamination and cannot be torn or coated after lamination. In addition, an identical serial number can be found on or next to the module nameplate.

Current grading label (if necessary): The modules of the same gear are second graded by rated current and marked for differentiation on the modules.

3.2 Wiring mode

The junction box of Huansheng Photovoltaic ABC photovoltaic module is located in the middle.

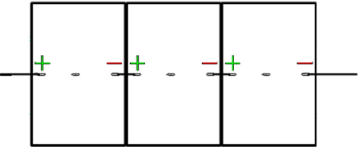
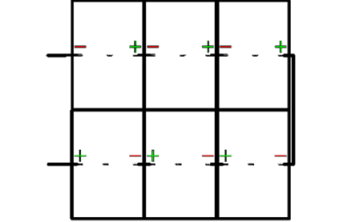
Please refer to the following table for the series connection mode of various modules.

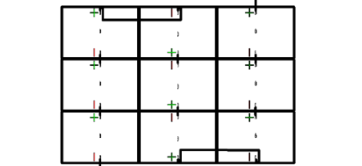
Junction box location	Module Installation type	Wiring diagram	
	Long side mounting for single row		<p>Transverse adjacent modules are connected directly with the shortest distance; If the wire is too long, the wire can be placed in the secondary beam for connection.</p>
	Long side mounting for double rows		<p>1) Transverse adjacent modules are connected directly with the shortest distance; If the wire is too long, the wire can be placed in the secondary beam for connection. 2) When connecting two adjacent rows of modules, the opposite polarity on the same side should be considered in the design and installation, as shown in the figure. The adjacent modules should be connected on the side, and the wires should not be exposed.</p>
	Short side mounting for single row		<p>For longitudinal installation, when two rows of modules are connected longitudinally, the polarity of the adjacent modules in the design and installation is opposite as shown in the figure. At the same time, the extension wire can be put into the secondary beam.</p>
	Short side mounting for double rows		<p>1) Vertically adjacent modules as shown in the figure are connected directly at the shortest distance ; 2) When two columns of adjacent modules are connected, the opposite polarity on the same side should be considered in the design and installation, as shown in the figure. The adjacent modules are connected on the side, and the wires can be put into the secondary beam.</p>

3.3 General safety

The design of Huansheng Photovoltaic module complies with IEC-61215 and IEC-61730 international standards. The application level is class A. the module can be used for systems with DC 50V or above 240W that the public may contact. The safety level of the module is class II and the fire protection level is class C.

No matter whether the PV module is connected to the system or not, appropriate protective measures shall be taken when contacting the module, such as insulating tools, safety helmets, insulating gloves, safety belts and safety insulating shoes. When you need to install, ground, wire and clean modules, please be sure to use appropriate electrical safety protection tools.

Under the sunlight, whether the module is connected with the electrical system or not, it can generate direct current, and touching the live parts of the module (such as connectors) may cause casualties. Avoid direct contact with photovoltaic modules, which may cause electric shock or cuts.

The installation of PV modules shall comply with the laws and regulations clearly stipulated by the relevant regions and countries where the PV modules are installed. If necessary, the construction permit and other certificates shall be obtained first.

The installation of PV modules shall be carried out by qualified professionals who have professional skills and knowledge and are familiar with the mechanical and electrical requirements of the system. The risk of possible injury during installation, including electric shock or cuts, shall be known in advance.

The roof system can only be installed on the roof with formal and complete structural analysis results after evaluation by construction experts.

Observe the safety rules for all installed modules. For example, wires and cables, connectors, charging controllers, inverters, batteries, etc., only equipment, connectors, wires and supports matching the solar power system can be used. If the photovoltaic system uses batteries, it shall follow the opinions of the battery manufacturer.

PV modules of the same size and model can be interconnected.

Please do not artificially focus light on modules.

3.4 Electrical safety

Please strictly follow the following electrical safety provisions to avoid any form of electrical safety accidents.

Please do not install or operate PV modules when it is wet or windy.

The DC voltage of photovoltaic modules may exceed 30V, and direct contact shall be avoided.

It is necessary to ensure that the connecting cable is fixed on the support frame for the installation of PV modules.

Where animals and children can reach, cables must be protected with conduits.

Please do not artificially modify or remove any modules and labels of PV modules.

Please do not install PV modules without safety precautions.

Do not use any means other than connectors for electrical connection.

The damaged PV module has the risk of electric shock and fire and should be replaced immediately.

The installation of PV module array must be carried out under the condition of electrical safety.

During installation, the voltage of PV modules in series shall not exceed the maximum system voltage.

It is forbidden to plug connectors of different manufacturers and models into each other.

Please do not use conventional PV modules to replace roof and wall materials.

When there is current or external current in the PV module, the PV module shall not be connected or disconnected.

Please do not use corrosive chemicals to coat the surface of photovoltaic modules.

Please do not touch the PV module when it is wet.

3.5 Operational safety

Before the PV modules arrive at the installation site, please do not open the packaging box. Please put the packaging box in a ventilated and dry environment.

During all handling, please ensure that the PV module will not be subject to large vibration. Improper handling and placement may cause the glass of photovoltaic modules to break or lose electrical performance and lose the use value of photovoltaic modules.

Handle and install PV modules with care. In any case, it is forbidden to lift the PV module by pulling the junction box or cable. Two or more people must hold the edge of the PV module with both hands.

It is forbidden to step on, stand on or sit on the PV module, which will damage the PV module and pose a risk of injury to people.

It is forbidden to place any heavy object on the front and back of the PV module, and do not place the PV module on the sharp object surface.

It is forbidden to attempt to disassemble the PV module, remove the nameplate of the PV module or the modules on the PV module.

It is strictly prohibited to brush paint or apply any other adhesive on the surface of photovoltaic modules.

Avoid scratching the back plate and glass surface of PV module.

It is strictly prohibited to drill holes on the frame of PV modules, which will reduce the load resistance of the frame and lead to the corrosion of the frame, which will lead to the invalidation of the limited warranty of PV modules.

Except for grounding, it is forbidden to scratch the anodic oxide layer on the surface of the aluminum alloy frame, which may lead to frame corrosion and affect the load resistance and longterm reliability of the frame.

It is strictly prohibited to repair or refit PV modules by yourself.

The surface of the touching photovoltaic module should be smooth, without sharp edges, burrs, etc.



Do not dispose of electrical appliances as unsorted municipal waste, use separate collection facilities.

Contact your local government for information regarding the collection systems available. If electrical appliances are disposed of in landfills or dumps, hazardous substances can leak into the groundwater and get into the food chain, damaging your health and well-being.

When replacing old appliances with new ones, the retailer is legally obligated to take back your old appliance for disposals at least free of charge.

3.6 Fire safety

Please consult local laws and regulations before installing PV modules, and comply with the requirements on building fire resistance.

When installing on the roof, the roof must be covered with a layer of fireproof materials suitable for this grade, and sufficient ventilation between the back plate and the installation surface must be ensured.

Different roof structures and installation methods will affect the fire safety performance of buildings. Improper installation may cause fire.

In order to ensure the fire rating on the roof, the minimum distance between the PV module frame and the roof surface is 10cm.

Please use appropriate PV module accessories such as fuse, circuit breaker and grounding connector according to local regulations.

Do not use PV modules if exposed flammable gases are present nearby.

4. Installation conditions

4.1 Installation site and working environment

Huansheng Photovoltaic modules are recommended to be installed in an environment where the operating ambient temperature is $-20\text{ }^{\circ}\text{C} \sim 50\text{ }^{\circ}\text{C}$. The limiting operating ambient temperature of PV modules is $-40\text{ }^{\circ}\text{C} \sim +70\text{ }^{\circ}\text{C}$ and the humidity is lower than 85%rh. The 98th percentile operational temperature of the module should not exceed $70\text{ }^{\circ}\text{C}$ under any mounting conditions.

Refer to figure below for Level 0 regions and its 98th percentile.

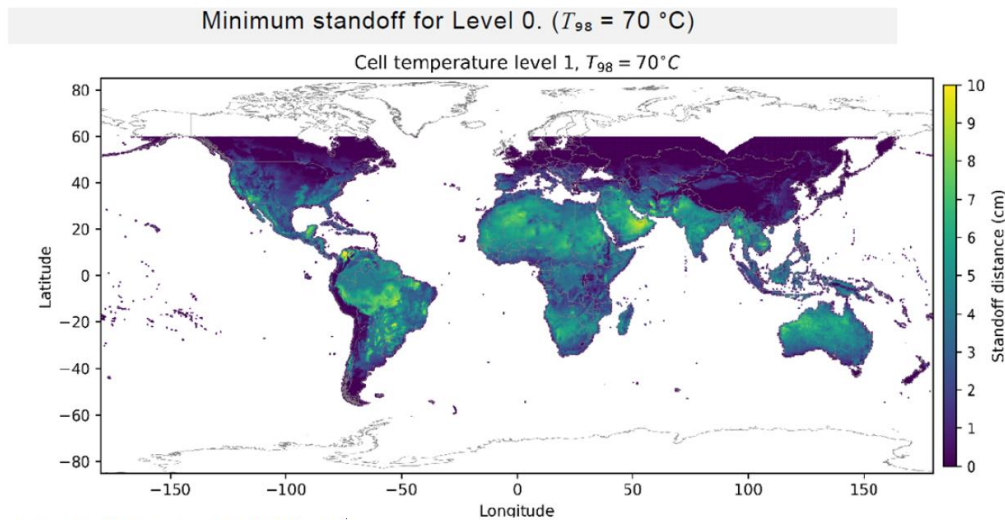

Source: IEC TS 63126 Edition 2

Huansheng Photovoltaic modules are applicable to the operating environment below 2000m above sea level.

Do not directly irradiate the artificial spotlight on the solar PV module.

When installing solar PV modules on the roof, a safe working area must be reserved between the edge of the roof and the outer edge of the PV module array.

When photovoltaic modules are stacked on the roof, the load of the roof shall be rechecked and the construction organization plan meeting the specification requirements shall be formulated.

When selecting the installation position of PV modules, the position where the sun can fully shine shall be selected to avoid partial or total shielding (trees, buildings, clothes, tools, packaging materials and other obstacles) on the surface of PV modules.

A safety factor (1.25) regarding the open circuit voltage (Voc) and short circuit current (Isc) needs to be set, considering that the irradiance of the installation site can sometimes be higher than $1000\text{W}/\text{m}^2$ and the temperature may be lower than $25\text{ }^{\circ}\text{C}$.

In order to make use of the power generated on the back side of the double-sided photovoltaic module, the back side barrier should be avoided.

Double-sided PV modules are not recommended to be installed in building attached PV systems (such as BAPVs) because the back side of the modules generates electricity by absorbing reflected light from the surface or scattered light from the surrounding environment.

The PV module shall be installed in a well-ventilated position to ensure sufficient air circulation at the back and side of the PV module, so that the heat generated during the working state of the PV module can be dissipated in time. Condensation or moisture can also be dissipated at the same time.

When used in areas with high wind pressure and snow pressure, the support and fixed structure shall be designed in strict accordance with local design codes to ensure that the external load does not exceed the mechanical strength limit that the PV module can withstand.

In salt spray, sulfide and ammonia environments (coastal, factory, volcanic and farm), corrosion may occur at the connection between modules and supports, or at the position where the grounding is connected.

Corrosion resistant materials (stainless steel or aluminum materials, etc.) must be used to contact the PV module, and the installation position shall be subject to anti-corrosion treatment.

4.2 Inclination angle selection

The inclination angle of PV module refers to the included angle between PV module and horizontal ground.

Different projects choose different installation inclination angles according to local conditions.

Each PV module of the same array must have the same direction and angle. Different installation directions and angles will lead to the difference in the total amount of solar radiation absorbed by photovoltaic modules, resulting in the mismatch loss of output power, thus reducing the operating efficiency of the system. Modules may be mounted at any angle from horizontal to vertical. Select the appropriate orientation to maximize sunlight exposure. For a good performance of the

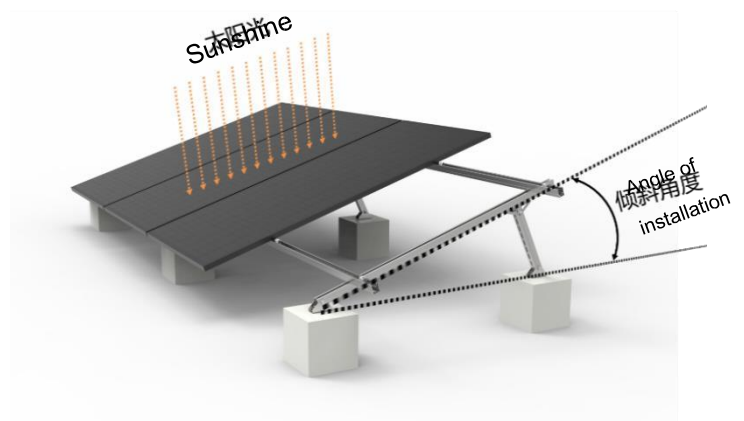

system (reduction of soiling effect/water pooling) a minimum of 10° tilt angle is recommended. The cleaning frequency must be increased for modules installed with a very low angle.

In order to achieve the maximum annual power generation of PV modules, the optimal orientation and inclination of PV modules in the installed area shall be selected to ensure that even on the day with the shortest sunshine throughout the year, the sunlight can still shine on the PV modules during the period from 9:00 to 15:00. The optimal inclination design of photovoltaic array shall comprehensively consider the climatic conditions such as monthly average irradiance, direct irradiance, scattering irradiance, wind speed, etc. of the installation site for many years. The inclination of photovoltaic modules shall maximize the annual radiation received on the photovoltaic modules. The selection of angle shall also consider the influence of natural conditions, such as local wind load, snow load, avoiding ponding and ash deposition on the surface of photovoltaic modules, etc. To maximise annual energy generation, In the Northern Hemisphere, the PV modules should typically face south, and in the Southern Hemisphere, the PV modules should typically face north.

5. Mechanical installation

5.1 General requirements

Ensure that the PV module installation method and support system are firm enough. The PV module mounting bracket must be made of corrosion-resistant and UV resistant materials.

The PV module must be firmly fixed to the bracket.

In areas with heavy snowfall, a higher support system shall be selected to avoid the lowest point of PV module being covered by snow for a long time. The lowest point of the PV module shall be at a certain height to prevent the PV module from being covered by weeds and trees on the ground.

When the PV module is installed parallel to the roof, the minimum gap between the PV module frame and the roof is 10cm.

The minimum installation distance between two adjacent PV modules is 10mm.

The maximum static test load passed by the PV module is front 3600/ back 1600 with Safety factor 1.5. The specific load depends on the installation mode of the PV module (please refer to the following). All load values mentioned in this manual are static test loads. Note: according to IEC 612152, 1.5 times of safety factor shall be considered when calculating the maximum design load; When calculating the wind load, the design maximum instantaneous gust load shall consider 3 times the safety factor.

The loads of the modules described in this manual are test loads. According to the installation requirements of IEC 61215-2, the corresponding maximum design load should be divided by at least with safety factor 1.5. The design load of the project needs to depend on the project location, climate, support structure, and relevant specifications. The support supplier and professional engineers are responsible for determining the design load, in accordance with local laws and regulations and the instructions of the structural engineer.

5.2 Mechanical installation for double glass module

The connection between Huansheng Photovoltaic double glass photovoltaic modules and the support system can be installed by bolts and blocks. PV modules must be installed according to the following suggestions and examples. If there are other installation methods, please consult Huansheng Photovoltaic digital energy in advance and obtain written consent, otherwise the warranty will be invalid.

5.2.1 Mounting pressure clamps

Specialized pressure clamps are used to mount modules as shown below.

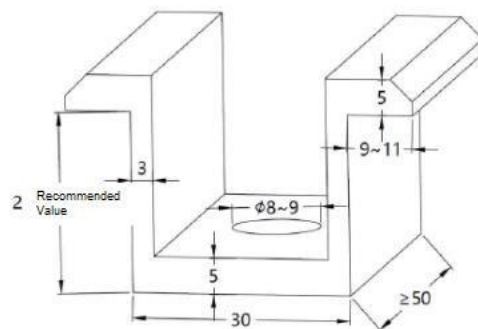
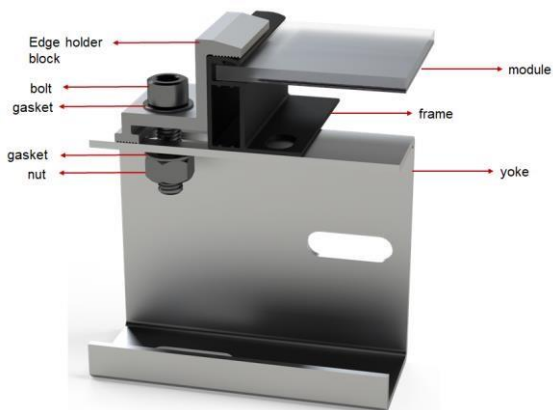
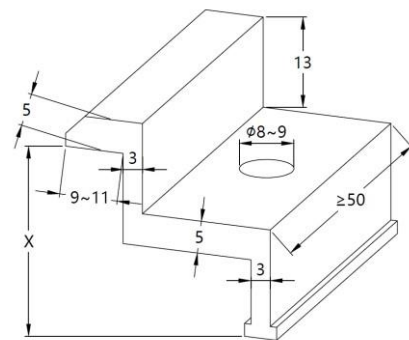
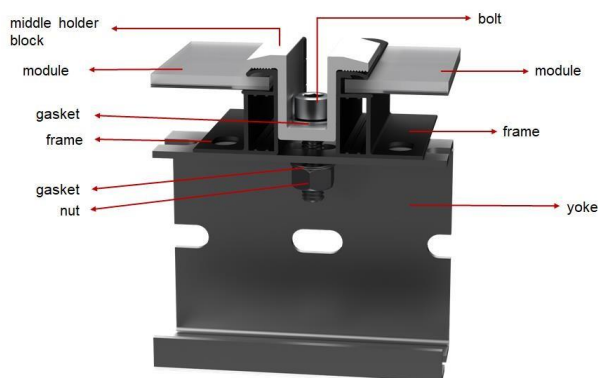

Under no circumstances should the clamp touch the glass or deform the frame. Be sure to avoid shadowing effect from the pressure clamp.

Be sure that pressure clamps will not fail due to deformation or corrosion while the entire module is under load. Pressure clamps > 50 mm in length and >3 mm in thickness are recommended. The overlapped distance between the pressure clamp and the module frame, D, shall be at least 7 mm but no more than 10 mm.

When choosing clamp-mounting, please be sure to use at least four clamps on each module. Depending on the local wind and snow loads, if excessive pressure load is expected, at least six clamps should be required to ensure the module can bear the load (more details, please contact HUANSHENG PHOTOVOLTAIC technical personnel)

The applied value of torque should refer to mechanical design standard and the bolt type customer is using, for example: M8: 16-20 N•m

5.2.2 Installation diagram and corresponding load

Double glass modules can be installed by clamps base on rails. Following are the installation diagram and corresponding loads. Here, L stand for long side of module, W stand for short side of module, black shadowing area stand for the installation area of the middle of clamp. Distance and length are provided in mm; pressure is provided in Pa.

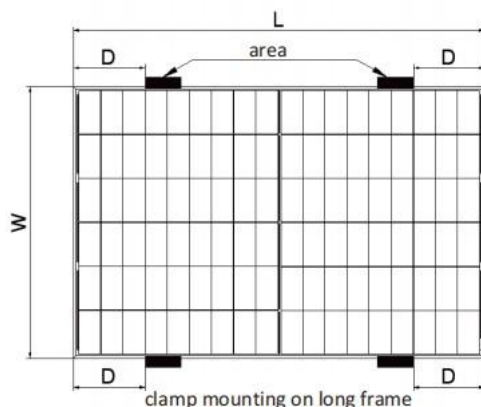

LAMP MOUNTING - LONG FRAME				
Module model	Module size [mm]	Load [Pa]	Installation area D	
			30/33mm frame	35/40mm frame
HSM-BD54-GAxx HSM-BD54-DAxxx	1722×1134	+5400/-2400	310≤D≤410	350≤D≤450
HSM-BD54-LAxxx HSM-BD54-WAxxx HSM-BE54-GCxxx HSM-BE54-GDxxx	1757×1134 1762×1134	+5400/-2400	295≤D≤395	360≤D≤460
HSM-BD54-GCxxx HSM-BE54-DCxxx	1802×1134 1800×1134	+5400/-2400	295≤D≤395	360≤D≤460
HSM-BD60-GAxxx HSM-BD60-LAxxx HSM-BD60-DAxxx HSM-BE60-GAxxx HSM-BE60-GCxxx HSM-BE60-DCxxx	1954×1134 1946×1134 1907×1134	+5400/-2400	350≤D≤400	360≤D≤460
HSM-BD72-GFxxx	2278×1134	+5400/-2400	430≤D≤530	450≤D≤550
HSM-BD72-DFxxx HSM-BE72-GAxxx	2323×1134	+5400/-2400	500≤D≤550	500≤D≤550
HSM-BD72-GCxxx HSM-BD72-WCxxx HSM-BD66-GRxxx HSM-BE72-GDxxx HSM-ND66-GRxxx	2382×1134	+5400/-2400	500≤D≤600	/
HSM-ND66-GKxxx	2384×1303	+5400/-2400	430≤D≤530	/
HSM-BD78-GFxxx HSM-BE78-GAxxx	2465×1134 2492×1134	+5400/-2400	550≤D≤650	/
HSM-BD60-GCxxx HSM-BE60-GDxxx	1995×1134	+5400/-2400	350≤D≤400	/

Table 1: Double glass modules clamp mounting diagram and corresponding loads, long frame (A)

Note: The above data is based on the static load requirements of IEC61215 standard

5.2.3 Bolts Mounting

Double glass modules can be installed by bolts base on rails. Using bolts to fix the module on the bracket through the mounting holes at the back of module's frame. Modules come standard with

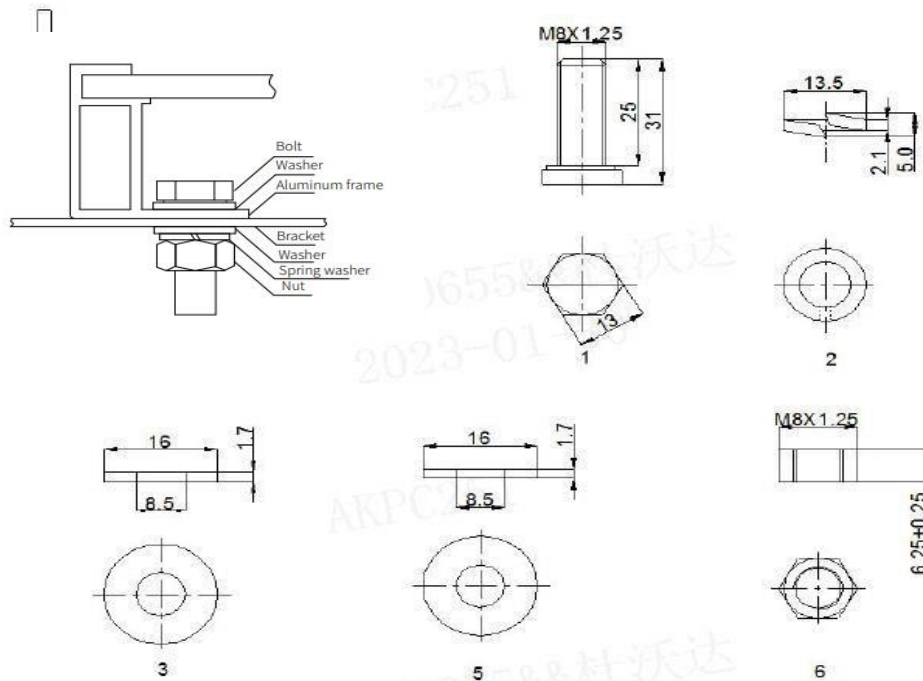

4 or 8 mounting holes, matching M8 bolts, as figure below:

No	Accessories	Model	Material
1	Bolt	M8*1.25	S35C
2	Spring washer	13.5*2.1	Mn65
3	Washer	16*1.7	Fe
4	Bracket	/	Q235
5	Washer	16*1.7	Fe
6	Nuts	M8*1.25	S35C

It is important to ensure the bolts do not fail due to deformation or corrosion during the overall load of the

module. HUANSHENG PHOTOVOLTAIC recommend the thickness of washer should $\geq 1.7\text{mm}$ and use M8 nut and bolt, the tightening torque should be between 16-20 Nm depending on the bolt grade.

5.2.4 Bolts Mounting diagram and corresponding load

Double glass modules bolt mounting diagram and corresponding loads as below diagram

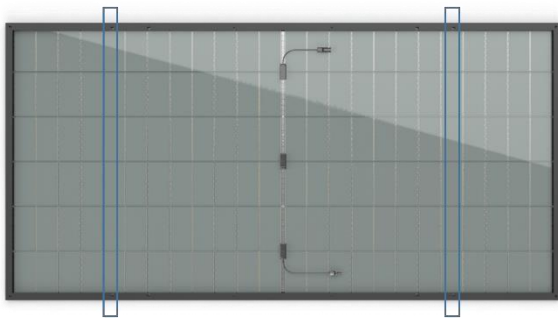

External 4-hole bolt mounting

The beam is perpendicular to the long frame

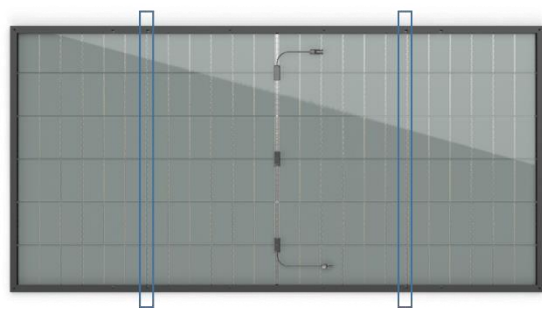

Internal 4-hole bolt mounting

The beam is perpendicular to the long frame

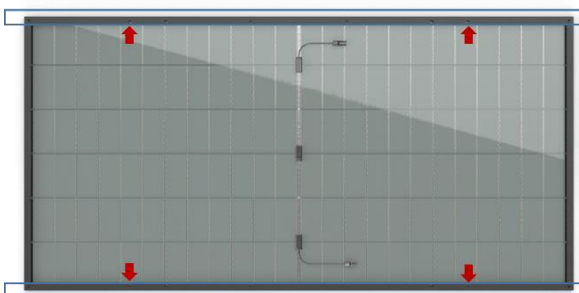

External 4-hole bolt mounting

The beam is parallel to the long frame

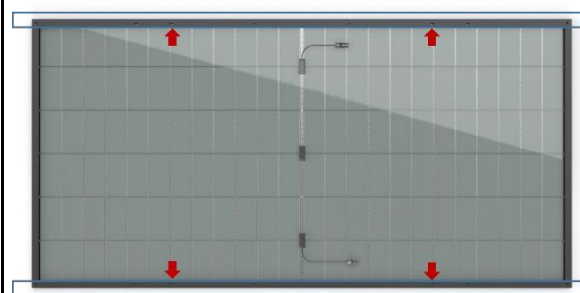

Internal 4-hole bolt mounting

The beam is parallel to the long frame

(D) BOLT MOUNTING - TRANSVERSAL

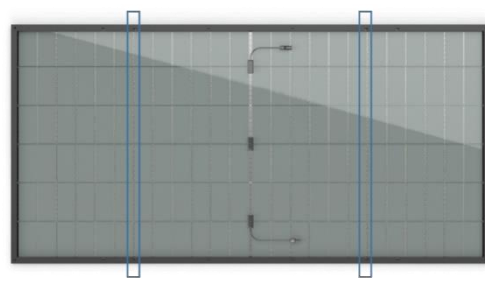
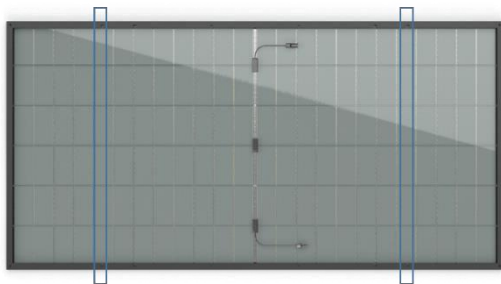

Module model	Module size [mm]	Frame thickness [mm]	Load [Pa] (Included with Safety factor 1.5)			
			4 inner mounting holes	4 outer mounting holes		
HSM-BD54-GAxx HSM-BD54-DAxxx	1722×1134	30/35/40				
HSM-BD54-LAxxx HSM-BD54- WAxxx HSM-BE54-GCxxx HSM-BE54- GDxxx	1757×1134 1762×1134	30/35/40				
HSM-BD54-GCxxx HSM-BE54-DCxxx	1802×1134 1800×1134	30/35/40				
HSM-BD60-GAxxx HSM-BD60- DAxxx HSM-BD60-LAxxx HSM- BE60-GAxxx HSM-BE60-GCxxx HSM-BE60- DCxxx	1954×1134 1946×1134 1907×1134	30/35/40			+5400/-2400	+2400/-2400
HSM-BD72-GFxxx HSM-BD72-DFxxx HSM-BE72-GAxxx	2278×1134 2323×1134	30/35/40 30/35/40			/	
HSM-BD72-GCxxx HSM-BD72-WCxxx HSM-BD66-GRxxx HSM-BE72-GDxxx HSM-ND66-GRxxx	2382×1134	30/35/40			+3600/-2400	
HSM-ND66-GKxxx	2384×1303	33			/	
HSM-BD78-GFxxx HSM-BE78-GAxxx	2465×1134 2492×1134	30/35/40			+3600/-2400	
HSM-BD60-GCxxx HSM-BE60-GDxxx	1995×1134	30/35/40			/	+5400/-2400

Table 2: Double glass modules bolt mounting diagram and corresponding loads, longitudinal (E)

Note: The above data is based on the static load requirements of IEC61215 standard

6. Electrical installation

6.1 Electrical performance

Please see the PV module product specifications for the electrical performance parameters of PV modules of Huansheng Photovoltaic. There is $\pm 3\%$ tolerance between the nominal values of the electrical performance parameters of photovoltaic modules such as I_{sc} , V_{oc} and P_{max} at the standard test conditions and bifacial nameplate irradiance. Standard test conditions (STC) for photovoltaic modules: irradiance 1000W/m^2 , cell temperature $25\text{ }^\circ\text{C}$, air quality AM1.5. The bifacial nameplate irradiance is 1000 W/m^2 on the module front and 135 W/m^2 on the module rear.

The maximum system voltage of Huansheng Photovoltaic modules is 1500V

When the PV modules are connected in a series, the final voltage is the sum of the single PV modules.

When the PV modules are connected in parallel, the final current is the sum of the single PV modules, as shown in the figure below. Photovoltaic modules of different electrical performance models cannot be connected in a string.

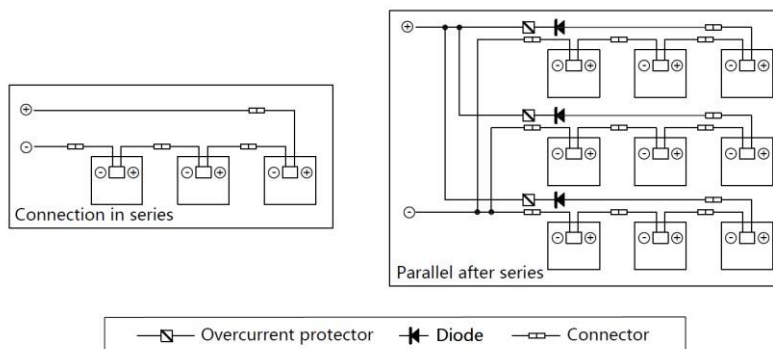

When the PV modules are connected in a series, the final voltage is the sum of the single PV modules.

When the PV modules are connected in parallel, the final current is the sum of the single PV modules, as shown in the figure below. Photovoltaic modules of different electrical performance models cannot be connected in a string.

If there is a reverse current exceeding the maximum fuse current of the PV module passing through the PV module, an overcurrent protector of the same specification must be used to protect the PV module. If the number of parallel connection is greater than two strings, each string of PV module must have an overcurrent protector, as shown in the above figure.

The voltage of the string shall not be higher than the maximum voltage that the system can withstand and the maximum input voltage of the inverter and other electrical equipment installed in the system. To ensure this, the open circuit voltage of the array needs to be calculated at the lowest expected ambient temperature at that location. The following formula can be used for calculation
Maximum system voltage $\geq N \times V_{oc} \times [1 + \beta \times (T_{min} - 25)]$ Of which:

N—Number of PV modules in series.

Voc—Indicates the open circuit voltage of each PV module (refer to the product label or data sheet).

TCvoc—Temperature coefficient indicating open circuit voltage of PV module (see data sheet).

Tmin—Indicates the minimum ambient temperature.

6.2 Cables and wiring

The protection grade of junction box of PV module is IP68, which is composed of connected cable and connector with IP68 protection grade. The PV module has a dedicated PV output cable with a positive pole and a negative pole connected to the inside of the junction box, and the other end is connected with a plug and play connector. The two PV modules can be connected in series by connecting the positive connector of the

PV module with the negative connector of the adjacent PV module.

According to the electrical design and construction specifications, regulations and corresponding regulatory requirements of the installation site, special solar cables and appropriate connector models shall be used to ensure good electrical and mechanical properties of the cables.

The solar PV module of Huansheng Photovoltaic adopts special PV cables with a crosssectional area of 4mm² or more and UV protection. All other cables used to connect the DC system shall have similar (or higher) specifications. Huansheng Photovoltaic recommends that all cables should be laid in appropriate pipelines or trunking and away from places prone to ponding.

For field wiring, PV special copper core cable with a minimum temperature resistance of 90 ° C, light resistance and a cross section of not less than 4mm² shall be used as the PV connecting wire.

6.3 Connectors

Please ensure that the connector is dry and clean. Confirm that the connector nut is tightened before wiring.

Do not connect when the connector is wet or in other abnormal conditions. The premise that the connector meets the IP68 protection grade is that the positive and negative poles are fully inserted, so the PV modules need to be connected as soon as possible after installation, or appropriate measures should be taken to avoid water vapor and dust infiltration inside the connector.

Avoid direct sunlight and immersion in water. Avoid direct contact between the connector and the ground or roof.

Please ensure that all electrical connections are secure. Incorrect connections may cause arc and electric shock risks.

It is forbidden to plug connectors of different models into each other.

The suppliers and types of connectors should be in accordance with the standard IEC 62852.

For more details, please see below ([except for HSM-ND66-GKxxx & HSM-ND66-GRxxx – Refer Section 6.3.2 for these modules](#)):

Connector Manufacturer	Type / Model	Standard	Junction box type	Junction box Manufacturer
Zhejiang Renhe Photovoltaic Technology Co., Ltd.	RHC2xyzu (x=S or L; y=N,M or T; z=V,A or C)	IEC 62852:2014+A1 EN 62852:2015+A1	FT50xy (x=1,2,3,4,5 or 6; y=A,B,C,D,E or F) (x=7,8,9,A,B or C; y=G,H,J or K) Junction box combination 1	Zhejiang Renhe Photovoltaic Technology Co., Ltd.
Staubli Electrical Connectors AG	PV-KST4-EVO 2/xy_UR (male) PV-KBT4-EVO 2/xy_UR (Female)	IEC 62852:2014+A1		
Staubli Electrical Connectors AG	PV-KST4-EVO2A/xy PV-KBT4-EVO2A/xy	IEC 62852:2014+A1		
Zhejiang Zhonghuan Sunter PV Technology Co., Ltd.	PV-ZH202B	IEC 62852:2014 IEC 62852:2014/AMD1:2020 EN 62852:2015/A1:2020	PV-ZH011C-5xyz (x=1 or 2; y=A or B; z=1 or 2 or 3) Junction box combination 2	Zhejiang Zhonghuan Sunter PV Technology Co., Ltd.
Staubli Electrical Connectors AG	PV-KST4-EVO 2/xy_UR (male) PV-KBT4-EVO 2/xy_UR (Female)	IEC 62852:2014+A1		
Staubli Electrical Connectors AG	PV-KST4-EVO2A/xy PV-KBT4-EVO2A/xy	IEC 62852:2014+A1		
Zerun Co., Ltd.	Z4S-abcd (a=C or P; b=T or H; c=A,B or C; d=A or B)	IEC 62852:2014+A1 EN 62852:2015+A1	Z8-abcd	Zerun Co., Ltd.

Staubli Electrical Connectors AG	PV-KST4-EVO 2/xy_UR (male) PV-KBT4-EVO 2/xy_UR (Female)	IEC 62852:2014+A1	(a=C, b=B,D,E or F, c=W,D,P,K,N or Q, d=K or O)	Junction box combination 3
Staubli Electrical Connectors AG	PV-KST4-EVO2A/xy PV-KBT4-EVO2A/xy	IEC 62852:2014+A1		
Zhejiang Aiko Solar Technology Co., Ltd.	AIKO-01C	IEC 62852:2014+A1 EN 62852:2015+A1	AIKO-JB-xyz-01 (x=1 or 2; y=1 or 2; z=C)	Zhejiang Aiko Solar Technology Co., Ltd.
Staubli Electrical Connectors AG	PV-KST4-EVO 2/xy_UR (male) PV-KBT4-EVO 2/xy_UR (Female)	IEC 62852:2014+A1	Junction box combination 4	

6.3.1 Bypass diode:

Bypass diode Manufacturer	Type / Model	Rating	Junction box type	Junction box Manufacturer
Zhejiang Renhe Photovoltaic Technology Co., Ltd.	Bypass diode 1 FMK5040D [FT50XY(X=4)]	Tj max =200°C	FT50xy (x=1,2,3,4,5 or 6; y=A,B,C,D,E or F) (x=7,8,9,A,B or C; y=G,H,J or K)	Zhejiang Renhe Photovoltaic Technology Co., Ltd.
Zhejiang Renhe Photovoltaic Technology Co., Ltd.	Bypass diode 2- MK4045 [FT50XY(X=8)]	Tj max =200°C	Junction box combination 1	
Zhejiang Zhonghuan Sunter PV Technology Co., Ltd.	35SQ045	Tj max =200°C	PV-ZH011C-5xyz (x=1 or 2; y=A or B; z=1 or 2 or 3)	Zhejiang Zhonghuan Sunter PV Technology Co., Ltd.
Zerun Co., Ltd.	35SQ045	Tj max =200°C	Z8-abcd (a=C, b=B,D,E or F, c=W,D,P,K,N or Q, d=K or O)	Zerun Co., Ltd.
1. Yangzhou Yangjie Electronic Technology Co., Ltd. 2. Panjit Electronics (Wuxi) CO., LTD. 3. Anhui Juxin Semiconductor Technology Co., Ltd. 4. ChangZhou Star Sea Electronics Co., Ltd. 5. Nantong Hornby Electronic Co., Ltd.	Bypass diode 1 35SQ045 (y=1)	Tj max =200°C	AIKO-JB-xyz-01 (x=1 or 2; y=1 or 2; z=C)	Zhejiang Aiko Solar Technology Co., Ltd.

<p>6. Hangzhou Daoming Microelectronics Co., Ltd. 7. Yangzhou Hongyang Technology Development Co., Ltd. 8. Zhejiang Zhonghuan Sunter PV Technology Co., Ltd. 9. NANTONG GAOXIN SCIENCE AND TECHNOLOGY DEVELOPMENT CO., LTD</p>	<p>Bypass diode 2 40SQ045 (y=2)</p>	<p>Tj max =200°C</p>	
---	--	----------------------	--

6.3.2 Connector type & Bypass diode for HSM-ND66-GKxxx & HSM-ND66-GRxxx

Combination 1				
Object	Manufacturer	Type / Model	Rating	Standard
Junction box	Zhejiang Renhe Photovoltaic Technology Co.,Ltd	FT50xy(x=1,2,3 or 4,y=B,Dor F)	Rated Voltage: 1500VDC Rated Current:25A x=4 Reverse Current:41A Degree of Protection:IP68(1m,1h) RTI=110°C	IEC 62790: 2014 EN 62790: 2015
Connector 1	Zhejiang Renhe Photovoltaic Technology Co.,Ltd	05-8	Rated voltage=1500VDC Rated current=30A	IEC 62852: 2014
Connector 2	Zhejiang Renhe Photovoltaic Technology Co.,Ltd	RHC2xyzu	Rated current=35A (4,0mm ²)	IEC 62852: 2014 EN 62852: 2015
Connector 3	Staubi Electrical Connectors AG	PV-KST4-EVO 2/xy_UR; PV-KBT4-EVO 2xy/_UR	Rated current=45A (4,0mm ²)	IEC 62852: 2014
Bypass diode 1	Zhejiang Renhe Photovoltaic Technology Co.,Ltd.	FMK5040D	Tjmax=200°C Rated current of box is 25A	—
Bypass diode 2		FMK5060D	Tjmax=200°C Rated current of box is 30A	—

Bypass diode 3		FMK4545D	Tjmax=200°C Rated current of box is 25A	—
Combination 2				
Junction box	Zerun Co., LTD	Z8-abcd (a=x, b=A or B, c=D or E or P or N or X, d=O)	Max. Voltage=1500V Rated Current=22A for Z8-abcd (c=D); 24A for Z8-abcd (c=E); 25A for Z8-abcd (c=P); 30A for Z8-abcd (c=N); 35A for Z8-abcd (c=X) Reverse current: 40A RTI= 110°C	IEC 62790: 2014 EN 62790: 2015
Connector 1	Zerun Co., LTD	Z4S-abcd	Max. Voltage=1500V Max. Current=40A	IEC 62852: 2014
Connector 2	Stäubli Electrical Connectors AG	PV-KST4-EVO 2/xy_UR; PV-KBT4-EVO 2/xy_UR	Max. Voltage=1500V Max. Current=45A for 4,0mm ² ; 53A for 6,0mm ²	IEC 62852: 2014
Bypass diode 1	Zerun Co., LTD Manufacturer: Anhui Juxin Semiconductor Technology Co., Ltd.	3045W	Tjmax=200°C Rated current of Box: 25A	—
Bypass diode 2		3045S	Tjmax=200°C Rated current of Box: 25A	—
Bypass diode 3		4045W	Tjmax=200°C Rated current of Box: 30A	—
Bypass diode 4		4045S	Tjmax=200°C Rated current of Box: 30A	—
Bypass diode 5		4545W	Tjmax=200°C Rated current of Box: 35A	—
Combination 3				
Junction box	SUZHOU UKT NEW ENERGY TECHNOLOGY CO., LTD	PV-JB12x(x=A or C or E or H or A-1 or T or A-25 or L or N1 or S1)	Rated Voltage: 1500VDC Rated Current: 30A for PV-JB12x(x=S1); 25A for PV-JB12x(x=A-25);	IEC 62790: 2014 EN 62790: 2015

			<p>20A for PV-JB12x(x=N1);</p> <p>18A for PV-JB12x(x=A or C or E or T or L);</p> <p>15A for PV-JB12x(x=A-1); 13A for PV-JB12x(x=H) Reverse</p> <p>Current :</p> <p>30A for PV-JB12x (x=A or C or E or H or A-1 or T or L)</p> <p>54A for PV-JB12x (x=A-25 or N1 or S1) RTI:</p> <p>110°C for 540Z(f1)(c);</p> <p>125°C for 644Z(f1)(c);</p> <p>120°C for A3XZG5(f1);</p>	
Connector 1	SUZHOU UKT NEW ENERGY TECHNOLOGY CO., LTD	PV-CO02-xy	<p>Max. Voltage=1500V</p> <p>Max. Current=45A</p>	IEC 62852: 2014
Connector 2	Stäubli Electrical Connectors AG	PV-KST4-EVO2/xy_UR; PV-KBT4EVO2/xy_UR	<p>Rated voltage=1500VDC</p> <p>Rated current=45A</p>	IEC 62852: 2014
Connector 3	Zhejiang Renhe Photovoltaic Technology Co., Ltd.	RHC2xyzu	Rated current=35A	IEC 62852: 2014 EN 62852:2015
Connector 4	Zerun Co., LTD.	Z4S-abcd	<p>System voltage: 1500VDC</p> <p>Rated current=40A</p>	IEC 62852: 2014 EN 62852:2015
Bypass diode 1	SUZHOU UKT NEW ENERGY TECHNOLOGY CO., LTD	UKTH4545-12 / TM3045-25	<p>Tjmax=200°C</p> <p>Rated current of Box: 25A</p>	—
Bypass diode 2		UKTH5045-12 / TM3045-30	<p>Tjmax=200°C</p> <p>Rated current of Box: 30A</p>	—
Combination 4				
Junction box	Yangzhou Langri New Energy Technology Co.,Ltd.	PV-LR-SH06x(x=1 or 2 or 3)	<p>Max. Voltage=1500V</p> <p>Rated Current:</p> <p>25A for PV-LRSH06x(x=2)A</p>	IEC 62790: 2014 EN 62790: 2015

			<p>30 A for PV-LR-SH06x(x=3)</p> <p>Reverse Current</p> <p>41A for PV-LR-SH06x(x=1 or 2 or 3)</p> <p>RTI= 115°C for PPE+PS</p> <p>RTI= 105°C for PA66</p> <p>RTI=110 °C for PX9406P</p>	
Connector	Yangzhou Langri New Energy Technology Co., Ltd.	PV-JY-0901-x (x=3,4,5)	Max. Voltage=1500V Max. Current=30A/34A/41A	IEC 62852: 2014
Bypass diode 1	PAN JIT INTERNATIONAL INC.	SBT3045VDC	Tjmax=200°C	—
Bypass diode 2	PAN JIT INTERNATIONAL INC.	GF5045	Tjmax=200°C	—
Combination 5				
Junction box	JIANGSU HUANXIN SEMICONDUCTOR CO.,LTD	PV-JB2101-xy (x=1, 2, 3; y=B)	<p>Rated Voltage: 1500VDC</p> <p>Rated Current:25A for x=1</p> <p>30A for x=2</p> <p>35A for x=3</p> <p>Reverse Current :40A</p> <p>RTI=110°C</p>	<p>IEC 62790: 2020</p> <p>EN 62790: 2020</p>
Connector 1	Staubli Electrical Connectors AG	PV-KST4-EVO2/xy_UR; PV-KBT4EVO2/xy_UR;	Max. Voltage=1500V Max. Current=45A	IEC 62852: 2014
Connector 2	Zhejiang Renhe Photovoltaic Technology Co.,Ltd	RHC2xyz(x=S or L; y=N,M or T; z=V,A or C)	Rated voltage=1500VDC Rated current=40A	IEC 62852: 2014
Connector 3	Zerun Co., LTD	Z4S-abcd	Rated voltage=1500VDC Rated current=40A	IEC 62852: 2014 EN 62852:2015
Bypass diode 1	JIANGSU HUANXIN SEMICODUCTOR CO.,LTD	SMK3045T	Tjmax=200°C Rated current=25A	—

Bypass diode 2		SMK5045D	Tjmax=200°C Rated current=30A	—
Bypass diode 3		MD3045S	Tjmax=200°C Rated current=25A	—
Combination 6				
Junction box	Zerun Co., LTD	Z8-abcd (a=C, b=B,D,E,F or G, c=W,D,P,K,N or Q, , d=K or O)	Max. Voltage=1500V Rated Current:20A for Z8abcd (c=W); 25A for Z8-abcd (c=P); 27A for Z8abcd (b=E,F or G,c=K);30A for Z8-abcd (c=N); Reverse current: 47,5A RTI= 110°C	IEC 62790: 2020 EN 62790: 2020
Cable 1	Zerun Co., LTD	62930 IEC 131 1X2,5...6,0mm ²	1X4.0 mm ² Rated voltage=1500V	EN 50618: 2014
Cable 2	Suzhou Baohing Electric Wire & Cable Co., Ltd.	62930 IEC 131 1X1,5...35mm ²	1X4.0 mm ² Rated voltage=1500V	EN 50618: 2014
Connector 1	Zerun Co., LTD	Z4S-abcd	Max. Voltage=1500V Max. Current=40A	IEC 62852: 2014
Connector 2	Stäubli Electrical Connectors AG	PV-KST4-EVO 2/xy_UR; PV-KBT4-EVO 2/xy_UR	Max. Voltage=1500V Max. Current: 45A for 4,0mm ² ; 53A for 6,0mm ²	IEC 62852: 2014
Connector 3		PV-KST4-EVO2A/xy; PV-KBT4-EVO2A/xy		
Connector 4		PV-KST4/xy-UR; PV-KBT4/xy-UR	Max. Voltage=1000V Max. Current: 39A	IEC 62852:2014
Bypass diode 1	Zerun Co., LTD Manufacturer: Anhui Juxin Semiconductor Technology Co., Ltd.	35SQ045	Tjmax=200°C Rated current of Box: 25A	—
Bypass diode 2		40SQ045	Tjmax=200°C Rated current of Box: 30A	—

Bypass diode 3		40SQ045B (only for c=N)	Tjmax=200°C Rated current of Box: 30A	—
Bypass diode 4		30SQ045C	Tjmax=200°C Rated current of Box: 25A	—
Combination 7				
Junction box	Zhejiang Renhe Photovoltaic Technology Co.,Ltd	FT70xy(x=1, 2, 3 or 4; y=A, B, C or D)	Max. Voltage=1500V Rated Current : 25A for FT70xy(x=1); 28A for FT70xy(x=2); 30A for FT70xy(x=3); 35A for FT70xy(x=4) Reverse current: 54A RTI= 110°C	IEC 62790: 2020 EN 62790: 2020
Connector	Zhejiang Renhe Photovoltaic Technology Co.,Ltd	RHC2xyzu	Rated current=35A (4,0mm ²)	EN 62852:2015 IEC 62852: 2014
Bypass diode	Zhejiang Renhe Photovoltaic Technology Co.,Ltd	PS50TA	Tjmax=200°C Rated current of Box: 30A	—
Combination 8				
Junction box	JIANGSU HUANXIN SEMICONDUCTOR CO.,LTD	PV-JB2203-xy (x=1 or 2; y=A or B)	Rated Voltage:1500VDC; Rated Current:25A for PV-JB2203-xy(x=1; y=A or B); Rated Current :30A for PV- JB2203- xy(x=2; y=A or B) Reverse Current :54A RTI=110°C	IEC 62790: 2020 EN 62790: 2020
Connector 1	Staubli Electrical Connectors AG	PV-KST4/xy-UR; PV-KBT4/xy-UR	Max. Voltage=1000V Max. Current=39A	IEC 62852:2014

Connector 2		PV-KST4 EVO 2/xy-UR; PV-KBT4 EVO 2/xy-UR	Max. Voltage=1500V Max. Current=45A	IEC 62852:2014
Connector 3	Zhejiang renhe Photovoltaic Technology Co.Ltd.	RHC2xyzu(X=S or L; y=N,M or T; z=V,A or C)	Rated voltage=1500VDC Rated current=40A	EN 62852:2015 IEC 62852:2014
Connector 4	Zerun Co., LTD	Z4S-abcd	Rated voltage=1500VDC Rated current=40A	EN 62852:2015 IEC 62852:2014
Connector 5	JIANGSU HUANXIN SEMICONDUCTOR CO.,LTD.	H4	Rated voltage=1500VDC Rated current=40A	EN 62852:2015+A1 IEC 62852:2014+A1
Bypass diode 1	JIANGSU HUANXIN SEMICODUCTOR CO.,LTD	30ST045C	Tjmax=200°C Rated current=25A	—
Bypass diode 2		40ST045C	Tjmax=200°C Rated current=30A	—

7. Grounding

In the design of PV modules, anodized corrosion-resistant aluminum alloy frame is used as a rigid support. In order to use safely and avoid lightning and electrostatic damage to PV modules, the PV module frame must be grounded. When grounding, the grounding device must be in full contact with the interior of the aluminum alloy to penetrate the oxide film on the frame surface.

The grounding hardware includes: grounding screw, flat washer, puncture gasket and grounding wire.

Except for the grounding wire, other related hardware shall be made of stainless steel. The grounding conductor or grounding wire adopts copper core wire, and the grounding conductor must be connected to the earth through a suitable grounding electrode. The third-party grounding device that meets the requirements of the installation ground electrical equipment specification can be used for the grounding of Huansheng Photovoltaic modules. The grounding device shall be installed and operated in accordance with the operation manual specified by the manufacturer.

The following are the recommended grounding methods:

On side C of PV module frame, there are Φ 4.2mm grounding hole, use separate grounding wire and relevant accessories to connect the aluminum alloy frame of the solar photovoltaic module and

connect the grounding wire to the earth. It is recommended to use m4x12mm grounding bolt and M4 nut, star washer and flat washer.

The recommended torque value of grounding bolt is $3\sim 7\text{N}\cdot\text{m}$, and the grounding wire adopts 4mm^2 copper core wire.

Unused PV module mounting holes on the frame can also be used for grounding.

8. PV module maintenance

The PV modules must be regularly inspected and maintained, especially within the warranty period, which is the responsibility of the user. And notify Huansheng Photovoltaic ' customer service personnel as soon as possible in case of any damage or other significant abnormalities of PV modules.

8.1 Clean

The power output of photovoltaic modules is related to the incident light intensity. Dust accumulation or other obstructions will reduce the power output of photovoltaic modules. The dirt on the PV module shall be cleaned in time.

As for cleaning frequency, it depends on the accumulation rate of dirt. If the PV module has enough inclination angle, the rainwater will clean the surface of the PV module, which can reduce the cleaning frequency.

It is recommended to use a sponge moistened with clean water to wipe the glass surface of photovoltaic modules. It is strictly prohibited to use cleaning agents containing acid or alkali to clean PV modules. It is forbidden to use brush and other tools with rough surface for cleaning.

It is recommended to clean PV modules in the early morning or evening when the light is weak and the temperature of PV modules is relatively low.

8.2 Visual inspection

Visually inspect the PV module for appearance defects, such as:

Whether the photovoltaic module glass is broken;

Whether the photovoltaic module backplane is cracked or otherwise abnormal;

Whether the junction box is damaged and whether the cable is damaged;

Whether the PV module is covered by foreign matters and shadows;

Check whether the bolts fixing PV module and bracket are loose or rusted, and adjust or replace them in time;

Check whether the PV module is well grounded.

8.3 Connector and cable inspection

It is recommended to carry out preventive inspection once every six months, such as:

Check the tightness of the connector and the firmness of the cable;

Check the junction box sealant for cracks.

9. Revision version and date

Rev 1.0, issued in May 2023;

Rev 1.1, revised in Sep 2023;

Rev 1.2, revised in Nov 2023;

Rev 1.3, revised in Dec 2023;

Rev 1.4, revised in Apr 2024;

Rev 1.5, revised in July 2024; Rev

1.6, revised in Aug 2024;

Rev 1.7, revised in Dec 2024.

Product information

All electrical data should be measured under below test conditions:

STC: AM=1.5 , E=1000W/m² , Tc=25°C;

The additional test conditions for Bifacial PV modules:

BNPI: E=1000W/m² + ϕ •135W/m²

BSI: E=1000W/m² + ϕ •300W/m²

Pmax of any individual module will be within $\pm 3\%$ tolerance of these specified values.

Voc of any individual module will be within $\pm 3\%$ tolerance of these specified values.

Isc of any individual module will be within $\pm 3\%$ tolerance of these specified values.

Electrical performance parameters in Table 1 are subject to technical and product innovations.

Information in this document is subject to change without notice.

Table 1: The electrical performance parameters for Huansheng Photovoltaic Double-Glass PV Module

Type of module	Maximum power (Pmax) [W]	Open-circuit voltage (Voc) [V]	Short-circuit current (Isc) [A]	Operating voltage at the maximum power (Vmp) [V]	Operating current at the maximum power (Imp) [A]	Fuse current (A)	Maximum system voltage (Vsys) [V]
Under STC							
HSM-BD78-GFxxx	650	58.68	14.14	48.55	13.39	30	1500
	655	58.74	14.21	48.61	13.48	30	1500
	660	58.8	14.28	48.67	13.57	30	1500
	665	58.86	14.35	48.73	13.65	30	1500
	670	58.92	14.42	48.79	13.74	30	1500
	675	58.98	14.49	48.85	13.82	30	1500
	680	59.04	14.56	48.91	13.91	30	1500
	685	59.10	14.63	48.97	13.99	30	1500
HSM-BE78-GAxxx	650	58.40	14.03	48.99	13.27	30	1500
	655	58.50	14.09	49.09	13.35	30	1500
	660	58.60	14.15	49.19	13.42	30	1500
	665	58.70	14.21	49.29	13.50	30	1500
	670	58.80	14.28	49.39	13.57	30	1500
	675	58.90	14.35	49.49	13.64	30	1500
	680	59.00	14.42	49.59	13.72	30	1500
	685	59.10	14.49	49.69	13.79	30	1500
HSM-BD72-GFxxx	585	53.84	13.90	44.50	13.15	25	1500
	590	53.94	13.98	44.60	13.23	25	1500
	595	54.04	14.06	44.70	13.32	25	1500
	600	54.14	14.14	44.80	13.40	25	1500
	605	54.24	14.22	44.90	13.48	25	1500
	610	54.34	14.30	45.00	13.56	25	1500
	615	54.44	14.38	45.10	13.64	25	1500
	620	54.57	14.46	45.20	13.72	25	1500
	625	54.70	14.54	45.30	13.80	25	1500
	630	54.83	14.62	45.40	13.88	25	1500

HSM-BD72-DFxxx	585	54.04	13.85	44.70	13.09	25	1500
	590	54.14	13.93	44.80	13.17	25	1500
	595	54.24	14.01	44.90	13.26	25	1500
	600	54.34	14.09	45.00	13.34	25	1500
	605	54.44	14.17	45.10	13.42	25	1500
	610	54.57	14.25	45.20	13.50	25	1500
	615	54.70	14.33	45.30	13.58	25	1500
	620	54.83	14.41	45.40	13.66	25	1500
HSM-BE72-GAxxx	600	53.90	14.05	45.00	13.34	25	1500
	605	54.00	14.11	45.10	13.42	25	1500
	610	54.10	14.17	45.20	13.50	25	1500
	615	54.20	14.23	45.30	13.58	25	1500
	620	54.30	14.30	45.40	13.66	25	1500
	625	54.40	14.37	45.50	13.74	25	1500
	630	54.50	14.44	45.60	13.82	25	1500
HSM-BE72-GDxxx	610	53.20	14.74	44.50	13.71	30	1500
	615	53.30	14.76	44.60	13.79	30	1500
	620	53.40	14.78	44.70	13.88	30	1500
	625	53.50	14.80	44.80	13.96	30	1500
	630	53.60	14.82	44.90	14.04	30	1500
	635	53.70	14.88	45.00	14.12	30	1500
	640	53.80	14.94	45.10	14.20	30	1500
	645	53.90	15.00	45.20	14.28	30	1500
	650	54.00	15.06	45.30	14.35	30	1500
	655	54.10	15.12	45.40	14.43	30	1500
	660	54.20	15.18	45.50	14.51	30	1500
HSM-BD72-GCxxx	610	53.20	14.58	44.50	13.71	30	1500
	615	53.30	14.64	44.60	13.79	30	1500
	620	53.40	14.70	44.70	13.88	30	1500
	625	53.50	14.76	44.80	13.96	30	1500
	630	53.60	14.82	44.90	14.04	30	1500

	635	53.70	14.88	45.00	14.12	30	1500
	640	53.80	14.94	45.10	14.20	30	1500
	645	53.90	15.00	45.20	14.27	30	1500
	650	54.00	15.06	45.30	14.35	30	1500
	655	54.10	15.12	45.40	14.43	30	1500
HSM-BD72-WCxxx	630	54.00	14.88	44.70	14.10	25A	1500
	635	54.10	14.94	44.80	14.18	25A	1500
	640	54.20	15.00	44.90	14.26	25A	1500
	645	54.30	15.06	45.00	14.34	25A	1500
	650	54.40	15.12	45.10	14.42	25A	1500
	655	54.50	15.18	45.20	14.50	25A	1500
	660	54.60	15.24	45.30	14.57	25A	1500
HSM-BD60-GAxxx	490	44.82	13.93	37.70	13.00	25	1500
	495	44.92	13.99	37.80	13.10	25	1500
	500	45.02	14.05	37.90	13.20	25	1500
	505	45.12	14.11	38.00	13.30	25	1500
	510	45.22	14.17	38.10	13.39	25	1500
	515	45.32	14.23	38.20	13.49	25	1500
	520	45.42	14.29	38.30	13.58	25	1500
	525	45.52	14.35	38.40	13.68	25	1500
HSM-BD60-DAxxx	490	44.82	13.93	37.70	13.00	25	1500
	495	44.92	13.99	37.80	13.10	25	1500
	500	45.02	14.05	37.90	13.20	25	1500
	505	45.12	14.11	38.00	13.30	25	1500
	510	45.22	14.17	38.10	13.39	25	1500
	515	45.32	14.23	38.20	13.49	25	1500
HSM-BE60-GAxxx	500	45.02	14.05	37.90	13.20	25	1500
	505	45.12	14.11	38.00	13.30	25	1500
	510	45.22	14.17	38.10	13.39	25	1500
	515	45.32	14.23	38.20	13.49	25	1500
	520	45.42	14.29	38.30	13.58	25	1500

	525	45.52	14.35	38.40	13.68	25	1500
HSM-BE60-GCxxx	490	44.60	14.51	37.40	13.11	30	1500
	495	44.70	14.54	37.50	13.21	30	1500
	500	44.80	14.57	37.60	13.30	30	1500
	505	44.90	14.60	37.70	13.40	30	1500
	510	45.00	14.63	37.80	13.50	30	1500
	515	45.10	14.66	37.90	13.59	30	1500
	520	45.20	14.69	38.00	13.69	30	1500
	525	45.30	14.72	38.10	13.79	30	1500
	530	45.40	14.76	38.20	13.88	30	1500
	535	45.50	14.80	38.30	13.97	30	1500
	540	45.60	14.84	38.40	14.07	30	1500
HSM-BE60-DCxxx	490	44.60	14.51	37.40	13.11	30	1500
	495	44.70	14.54	37.50	13.21	30	1500
	500	44.80	14.57	37.60	13.30	30	1500
	505	44.90	14.60	37.70	13.40	30	1500
	510	45.00	14.63	37.80	13.50	30	1500
	515	45.10	14.66	37.90	13.59	30	1500
	520	45.20	14.69	38.00	13.69	30	1500
	525	45.30	14.72	38.10	13.79	30	1500
	530	45.40	14.76	38.20	13.88	30	1500
HSM-BE60-GDxxx	510	44.48	14.71	37.20	13.72	30	1500
	515	44.58	14.77	37.30	13.81	30	1500
	520	44.68	14.83	37.40	13.91	30	1500
	525	44.78	14.89	37.50	14.01	30	1500
	530	44.88	14.95	37.60	14.10	30	1500
	535	44.98	15.01	37.70	14.20	30	1500
	540	45.08	15.07	37.80	14.29	30	1500
	545	45.18	15.13	37.90	14.39	30	1500
	550	45.28	15.19	38.00	14.48	30	1500
HSM-BD60-GCxxx	500	44.92	14.32	37.32	13.40	30	1500
	505	45.00	14.40	37.40	13.51	30	1500

	510	45.08	14.48	37.48	13.61	30	1500
	515	45.16	14.56	37.56	13.72	30	1500
	520	45.24	14.64	37.64	13.82	30	1500
	525	45.32	14.72	37.72	13.92	30	1500
	530	45.40	14.80	37.80	14.03	30	1500
	535	45.48	14.88	37.88	14.13	30	1500
	540	45.56	14.96	37.96	14.23	30	1500
	545	45.64	15.04	38.04	14.33	30	1500
HSM-BD54-GAxxx	440	40.82	13.92	34.38	12.80	25	1500
	445	40.88	14.02	34.44	12.93	25	1500
	450	40.94	14.12	34.50	13.05	25	1500
	455	41.00	14.22	34.56	13.17	25	1500
	460	41.06	14.25	34.62	13.29	25	1500
	465	41.12	14.29	34.68	13.41	25	1500
	470	41.18	14.32	34.74	13.54	25	1500
HSM-BD54-DAxxx	440	40.82	13.92	34.38	12.80	25	1500
	445	40.88	14.02	34.44	12.93	25	1500
	450	40.94	14.12	34.50	13.05	25	1500
	455	41.00	14.22	34.56	13.17	25	1500
	460	41.06	14.25	34.62	13.29	25	1500
	465	41.12	14.29	34.68	13.41	25	1500
HSM-BE54-GCxxx	445	40.20	14.57	33.80	13.17	30	1500
	450	40.30	14.60	33.90	13.28	30	1500
	455	40.40	14.63	34.00	13.39	30	1500
	460	40.50	14.66	34.10	13.50	30	1500
	465	40.60	14.69	34.20	13.60	30	1500
	470	40.70	14.72	34.30	13.71	30	1500
	475	40.80	14.76	34.40	13.81	30	1500
	480	40.90	14.80	34.50	13.92	30	1500
	485	41.00	14.84	34.60	14.02	30	1500
HSM-BE54-DCxxx	445	40.20	14.57	33.80	13.17	30	1500
	450	40.30	14.60	33.90	13.28	30	1500
	455	40.40	14.63	34.00	13.39	30	1500

	460	40.50	14.66	34.10	13.50	30	1500
	465	40.60	14.69	34.20	13.60	30	1500
	470	40.70	14.72	34.30	13.71	30	1500
	475	40.80	14.76	34.40	13.81	30	1500
HSM-BE54-GDxxx	460	40.06	14.75	33.50	13.74	30	1500
	465	40.16	14.81	33.60	13.85	30	1500
	470	40.26	14.87	33.70	13.95	30	1500
	475	40.36	14.93	33.80	14.06	30	1500
	480	40.46	14.99	33.90	14.16	30	1500
	485	40.56	15.05	34.00	14.27	30	1500
	490	40.66	15.11	34.10	14.38	30	1500
	495	40.76	15.17	34.20	14.48	30	1500
HSM-BD54-GCxxx	460	40.27	14.69	33.44	13.76	30	1500
	465	40.37	14.75	33.54	13.87	30	1500
	470	40.50	14.82	33.64	13.98	30	1500
	475	40.63	14.89	33.74	14.09	30	1500
	480	40.76	14.96	33.84	14.19	30	1500
	485	40.89	15.03	33.94	14.30	30	1500
	490	41.02	15.10	34.04	14.40	30	1500
HSM-BD66-GRxxx	610	48.50	16.06	41.20	14.81	30	1500
	615	48.60	16.13	41.30	14.90	30	1500
	620	48.70	16.20	41.40	14.98	30	1500
	625	48.80	16.27	41.50	15.07	30	1500
	630	48.90	16.34	41.60	15.15	30	1500
	635	49.00	16.41	41.70	15.23	30	1500
	640	49.10	16.48	41.80	15.32	30	1500
	645	49.20	16.55	41.90	15.40	30	1500
	650	49.30	16.62	42.00	15.48	30	1500
	655	49.40	16.69	42.10	15.56	30	1500
	660	49.50	16.76	42.20	15.65	30	1500
HSM-ND66-GRxxx	615	48.72	16.00	40.79	15.08	30	1500

	620	48.94	16.05	40.98	15.13	30	1500
	625	49.16	16.10	41.18	15.18	30	1500
	630	49.38	16.14	41.40	15.22	30	1500
HSM-ND66-GKxxx	700	48.26	18.40	40.31	17.37	35	1500
	705	48.48	18.44	40.50	17.41	35	1500
	710	48.70	18.48	40.69	17.45	35	1500
	715	48.92	18.52	40.89	17.49	35	1500
	720	49.14	18.56	41.08	17.53	35	1500
	725	49.36	18.60	41.27	17.57	35	1500
Under BNPI							
HSM-BD78-GFxxx	690	58.68	15.03	48.60	14.20	30	1500
	695	58.74	15.10	48.66	14.29	30	1500
	700	58.80	15.17	48.72	14.37	30	1500
	705	58.86	15.24	48.78	14.46	30	1500
	710	58.92	15.31	48.84	14.54	30	1500
	715	58.98	15.38	48.90	14.63	30	1500
	720	59.04	15.45	48.96	14.71	30	1500
	725	59.10	15.52	49.02	14.79	30	1500
HSM-BE78-GAxxx	685	58.40	14.80	48.99	13.99	30	1500
	690	58.50	14.86	49.09	14.06	30	1500
	695	58.60	14.92	49.19	14.13	30	1500
	700	58.70	14.98	49.29	14.21	30	1500
	705	58.80	15.05	49.39	14.28	30	1500
	710	58.90	15.12	49.49	14.35	30	1500
	715	59.00	15.19	49.59	14.42	30	1500
	720	59.10	15.26	49.69	14.49	30	1500
HSM-BD72-GFxxx	615	53.93	14.52	44.60	13.79	25	1500
	620	54.03	14.60	44.70	13.88	25	1500
	625	54.13	14.68	44.80	13.96	25	1500
	630	54.23	14.76	44.90	14.04	25	1500
	635	54.33	14.84	45.00	14.12	25	1500

	640	54.43	14.92	45.10	14.20	25	1500
	645	54.53	15.00	45.20	14.28	25	1500
	650	54.63	15.08	45.30	14.35	25	1500
	655	54.73	15.16	45.40	14.43	25	1500
	660	54.83	15.24	45.50	14.51	25	1500
HSM-BD72-DFxxx	615	54.13	14.46	44.80	13.73	25	1500
	620	54.23	14.54	44.90	13.81	25	1500
	625	54.33	14.62	45.00	13.89	25	1500
	630	54.43	14.70	45.10	13.97	25	1500
	635	54.53	14.78	45.20	14.05	25	1500
	640	54.63	14.86	45.30	14.13	25	1500
	645	54.73	14.94	45.40	14.21	25	1500
	650	54.83	15.02	45.50	14.29	25	1500
HSM-BE72-GAxxx	630	53.90	14.82	45.00	14.01	25	1500
	635	54.00	14.88	45.10	14.08	25	1500
	640	54.10	14.94	45.20	14.16	25	1500
	645	54.20	15.00	45.30	14.24	25	1500
	650	54.30	15.07	45.40	14.32	25	1500
	655	54.40	15.14	45.50	14.40	25	1500
	660	54.50	15.21	45.60	14.48	25	1500
HSM-BE72-GDxxx	645	53.20	15.56	44.50	14.50	30	1500
	650	53.30	15.58	44.60	14.58	30	1500
	655	53.40	15.60	44.70	14.66	30	1500
	660	53.50	15.62	44.80	14.74	30	1500
	665	53.60	15.64	44.90	14.82	30	1500
	670	53.70	15.70	45.00	14.89	30	1500
	675	53.80	15.76	45.10	14.97	30	1500
	680	53.90	15.82	45.20	15.05	30	1500
	685	54.00	15.88	45.30	15.13	30	1500
	690	54.10	15.94	45.40	15.20	30	1500
	695	54.20	16.00	45.50	15.28	30	1500
HSM-BD72-GCxxx	665	53.20	15.73	44.50	14.95	30	1500

	670	53.30	15.81	44.60	15.03	30	1500
	675	53.40	15.89	44.70	15.11	30	1500
	680	53.50	15.97	44.80	15.18	30	1500
	685	53.60	16.05	44.90	15.26	30	1500
	690	53.70	16.13	45.00	15.34	30	1500
	695	53.80	16.21	45.10	15.42	30	1500
	700	53.90	16.29	45.20	15.49	30	1500
	705	54.00	16.37	45.30	15.57	30	1500
	710	54.10	16.45	45.40	15.64	30	1500
HSM-BD60-GAxxx	515	44.82	14.70	37.70	13.67	25	1500
	520	44.92	14.77	37.80	13.76	25	1500
	525	45.02	14.84	37.90	13.86	25	1500
	530	45.12	14.91	38.00	13.95	25	1500
	535	45.22	14.98	38.10	14.05	25	1500
	540	45.32	15.05	38.20	14.14	25	1500
	545	45.42	15.12	38.30	14.23	25	1500
	550	45.52	15.19	38.40	14.33	25	1500
HSM-BD60-LAxxx	500	45.02	14.05	37.90	13.20	25	1500
	505	45.12	14.11	38.00	13.30	25	1500
	510	45.22	14.17	38.10	13.39	25	1500
	515	45.32	14.23	38.20	13.49	25	1500
	520	45.42	14.29	38.30	13.58	25	1500
HSM-BD60-DAxxx	515	44.82	14.70	37.70	13.67	25	1500
	520	44.92	14.77	37.80	13.76	25	1500
	525	45.02	14.84	37.90	13.86	25	1500
	530	45.12	14.91	38.00	13.95	25	1500
	535	45.22	14.98	38.10	14.05	25	1500
	540	45.32	15.05	38.20	14.14	25	1500
HSM-BE60-GAxxx	525	45.02	14.84	37.90	13.86	25	1500
	530	45.12	14.91	38.00	13.95	25	1500
	535	45.22	14.98	38.10	14.05	25	1500
	540	45.32	15.05	38.20	14.14	25	1500
	545	45.42	15.12	38.30	14.23	25	1500

	550	45.52	15.19	38.40	14.33	25	1500
HSM-BE60-GCxxx	520	44.60	15.24	37.40	13.91	30	1500
	525	44.70	15.28	37.50	14.01	30	1500
	530	44.80	15.32	37.60	14.10	30	1500
	535	44.90	15.36	37.70	14.20	30	1500
	540	45.00	15.40	37.80	14.29	30	1500
HSM-BE60-DCxxx	545	45.10	15.44	37.90	14.39	30	1500
	550	45.20	15.48	38.00	14.48	30	1500
	555	45.30	15.52	38.10	14.57	30	1500
	560	45.40	15.56	38.20	14.67	30	1500
	565	45.50	15.60	38.30	14.76	30	1500
	570	45.60	15.64	38.40	14.85	30	1500
	520	44.60	15.24	37.40	13.91	30	1500
HSM-BE60-GDxxx	525	44.70	15.28	37.50	14.01	30	1500
	530	44.80	15.32	37.60	14.10	30	1500
	535	44.90	15.36	37.70	14.20	30	1500
	540	45.00	15.40	37.80	14.29	30	1500
	545	45.10	15.44	37.90	14.39	30	1500
	550	45.20	15.48	38.00	14.48	30	1500
	555	45.30	15.52	38.10	14.57	30	1500
	560	45.40	15.56	38.20	14.67	30	1500
	540	44.48	15.52	37.20	14.52	30	1500
HSM-BE60-GDxxx	545	44.58	15.58	37.30	14.62	30	1500
	550	44.68	15.64	37.40	14.71	30	1500
	555	44.78	15.70	37.50	14.81	30	1500
	560	44.88	15.76	37.60	14.90	30	1500
	565	44.98	15.82	37.70	14.99	30	1500
	570	45.08	15.88	37.80	15.09	30	1500
	575	45.18	15.94	37.90	15.18	30	1500
	580	45.28	16.00	38.00	15.27	30	1500
	HSM-BD60-GCxxx	545	44.92	15.44	37.23	14.64	30
550		45.00	15.52	37.31	14.75	30	1500

	555	45.08	15.60	37.39	14.85	30	1500
	560	45.16	15.68	37.47	14.95	30	1500
	565	45.24	15.76	37.55	15.05	30	1500
	570	45.32	15.84	37.63	15.15	30	1500
	575	45.40	15.92	37.71	15.25	30	1500
	580	45.48	16.00	37.79	15.35	30	1500
	585	45.56	16.08	37.87	15.45	30	1500
	590	45.64	16.16	37.95	15.55	30	1500
HSM-BD54-GAxxx	460	40.82	14.53	34.38	13.39	25	1500
	465	40.88	14.63	34.44	13.51	25	1500
	470	40.94	14.73	34.50	13.63	25	1500
	475	41.00	14.83	34.56	13.75	25	1500
	480	41.06	14.93	34.62	13.87	25	1500
	485	41.12	15.03	34.68	13.99	25	1500
	490	41.18	15.13	34.74	14.11	25	1500
HSM-BD54-DAxxx	460	40.82	14.53	34.38	13.39	25	1500
	465	40.88	14.63	34.44	13.51	25	1500
	470	40.94	14.73	34.50	13.63	25	1500
	475	41.00	14.83	34.56	13.75	25	1500
	480	41.06	14.93	34.62	13.87	25	1500
	485	41.12	15.03	34.68	13.99	25	1500
HSM-BD54-LAxxx	445	40.88	14.02	34.44	12.93	25	1500
	450	40.94	14.12	34.50	13.05	25	1500
	455	41.00	14.22	34.56	13.17	25	1500
	460	41.06	14.25	34.62	13.29	25	1500
	465	41.12	14.29	34.68	13.41	25	1500
	470	41.18	14.32	34.74	13.54	25	1500
HSM-BD54-WAxxx	460	41.06	14.25	34.62	13.29	25	1500
	465	41.12	14.29	34.68	13.41	25	1500
	470	41.18	14.32	34.74	13.54	25	1500
	475	41.24	14.35	34.80	13.66	25	1500

HSM-BE54-GCxxx	470	40.20	15.37	33.80	13.91	30	1500
	475	40.30	15.40	33.90	14.02	30	1500
	480	40.40	15.43	34.00	14.13	30	1500
	485	40.50	15.46	34.10	14.23	30	1500
	490	40.60	15.49	34.20	14.33	30	1500
	495	40.70	15.52	34.30	14.44	30	1500
	500	40.80	15.56	34.40	14.54	30	1500
	505	40.90	15.60	34.50	14.64	30	1500
	510	41.00	15.64	34.60	14.75	30	1500
HSM-BE54-DCxxx	470	40.20	15.37	33.80	13.91	30	1500
	475	40.30	15.40	33.90	14.02	30	1500
	480	40.40	15.43	34.00	14.13	30	1500
	485	40.50	15.46	34.10	14.23	30	1500
	490	40.60	15.49	34.20	14.33	30	1500
	495	40.70	15.52	34.30	14.44	30	1500
	500	40.80	15.56	34.40	14.54	30	1500
HSM-BE54-GDxxx	485	40.06	15.56	33.50	14.48	30	1500
	490	40.16	15.62	33.60	14.59	30	1500
	495	40.26	15.68	33.70	14.70	30	1500
	500	40.36	15.74	33.80	14.80	30	1500
	505	40.46	15.80	33.90	14.90	30	1500
	510	40.56	15.86	34.00	15.01	30	1500
	515	40.66	15.92	34.10	15.11	30	1500
	520	40.76	15.98	34.20	15.21	30	1500
HSM-BD54-GCxxx	500	40.33	15.76	33.45	14.96	30	1500
	505	40.43	15.86	33.55	15.06	30	1500
	510	40.53	15.96	33.65	15.17	30	1500
	515	40.63	16.06	33.75	15.27	30	1500
	520	40.73	16.16	33.85	15.37	30	1500
	525	40.83	16.26	33.95	15.47	30	1500
	530	40.93	16.36	34.05	15.57	30	1500
HSM-BD66-GRxxx	660	48.50	17.20	41.20	16.03	30	1500

	665	48.60	17.27	41.30	16.11	30	1500
	670	48.70	17.34	41.40	16.19	30	1500
	675	48.80	17.41	41.50	16.27	30	1500
	680	48.90	17.48	41.60	16.35	30	1500
	685	49.00	17.55	41.70	16.43	30	1500
	690	49.10	17.62	41.80	16.51	30	1500
	695	49.20	17.69	41.90	16.59	30	1500
	700	49.30	17.76	42.00	16.67	30	1500
	705	49.40	17.83	42.10	16.75	30	1500
	710	49.50	17.90	42.20	16.83	30	1500
HSM-ND66-GRxxx	679	48.86	17.66	40.79	16.65	30	1500
	685	49.11	17.73	41.00	16.71	30	1500
	690	49.30	17.77	41.20	16.75	30	1500
	695	49.50	17.81	41.40	16.79	30	1500
HSM-ND66-GKxxx	773	48.41	20.31	40.31	19.18	35	1500
	779	48.64	20.36	20.40	20.45	35	1500
	784	48.85	20.40	40.69	19.27	35	1500
	790	49.08	20.45	40.92	19.31	35	1500
	795	49.29	20.49	41.09	19.35	35	1500
	801	49.52	20.54	41.29	19.40	35	1500