

Eigentum der Firma Leibinger GmbH 79331 Teningen. Vervielfältigung, sowie jede mißbräuchliche Verwendung, insbesondere Überlassung an Dritte oder Verwendung zu anderen als dem vereinbarten Zweck, berechtigt zur Forderung von Schadenersatz.

Property of company Leibinger GmbH 79331 Teningen. Reproduction as well as any misuse particular transfer to third parties or use to other than the purpose agreed entitled to claim damages.

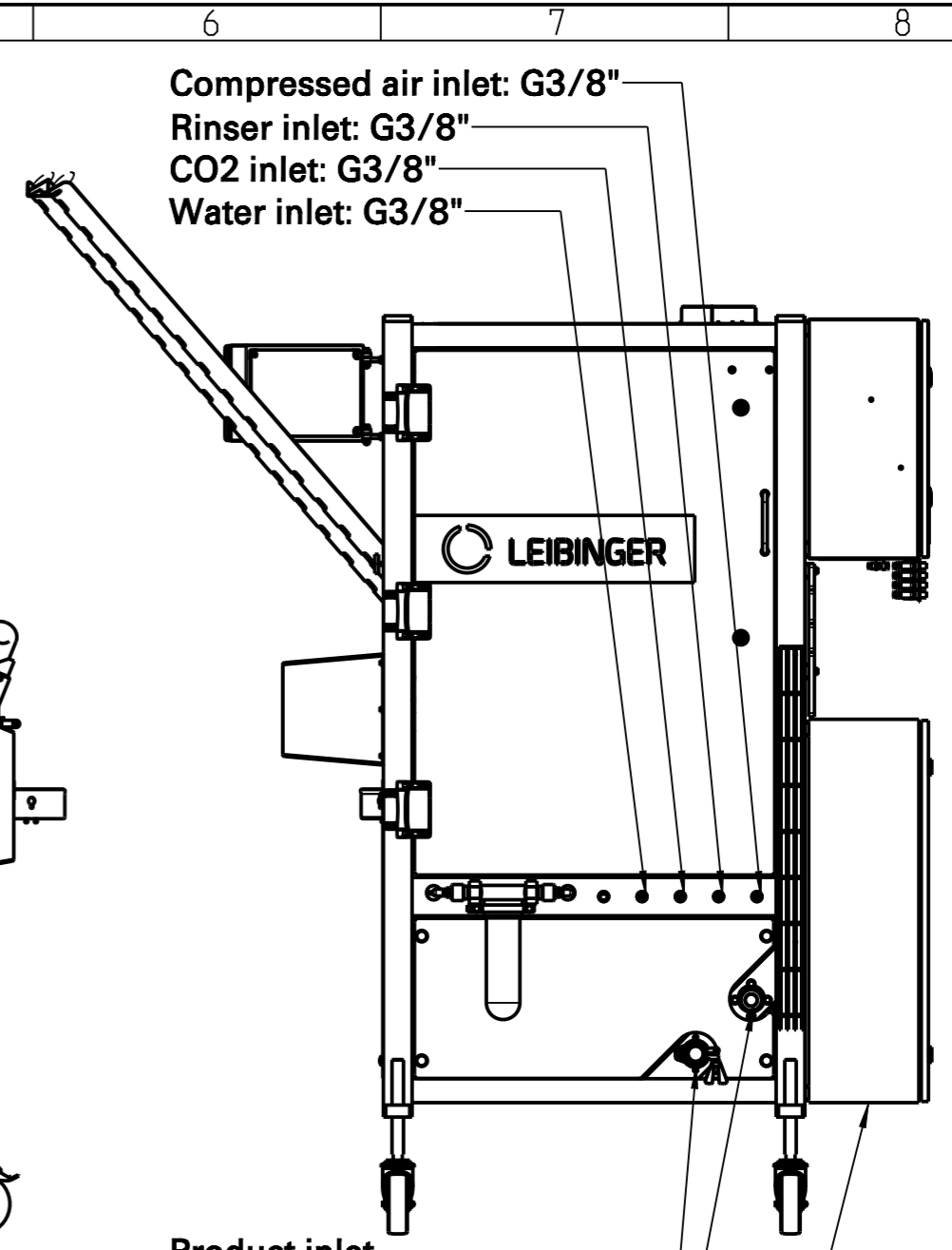
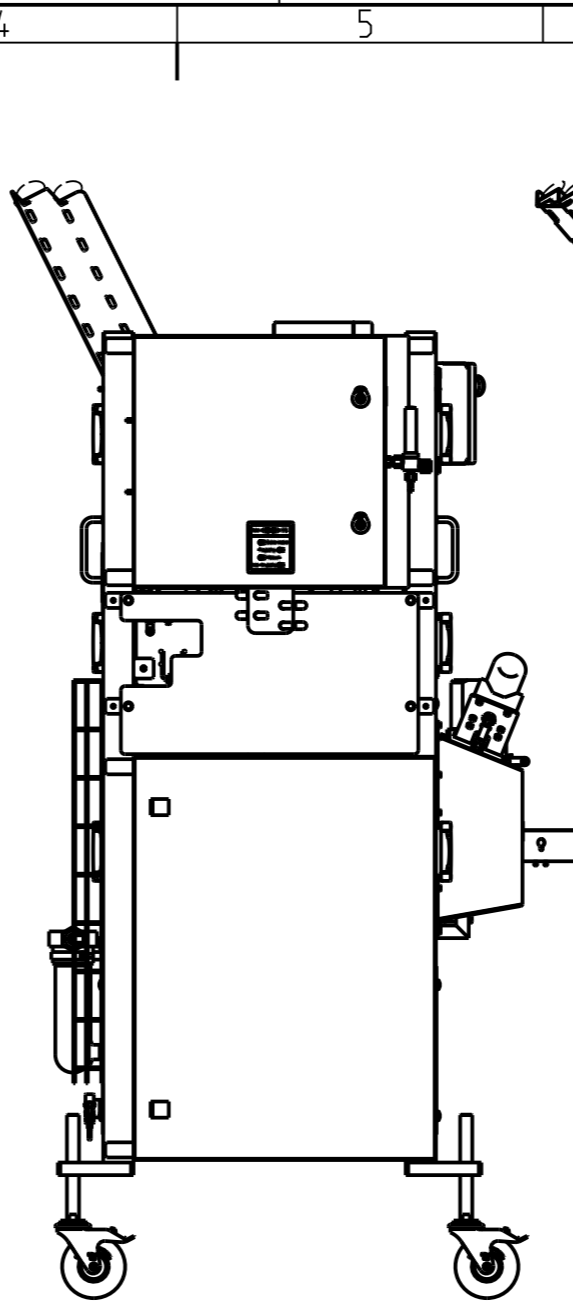
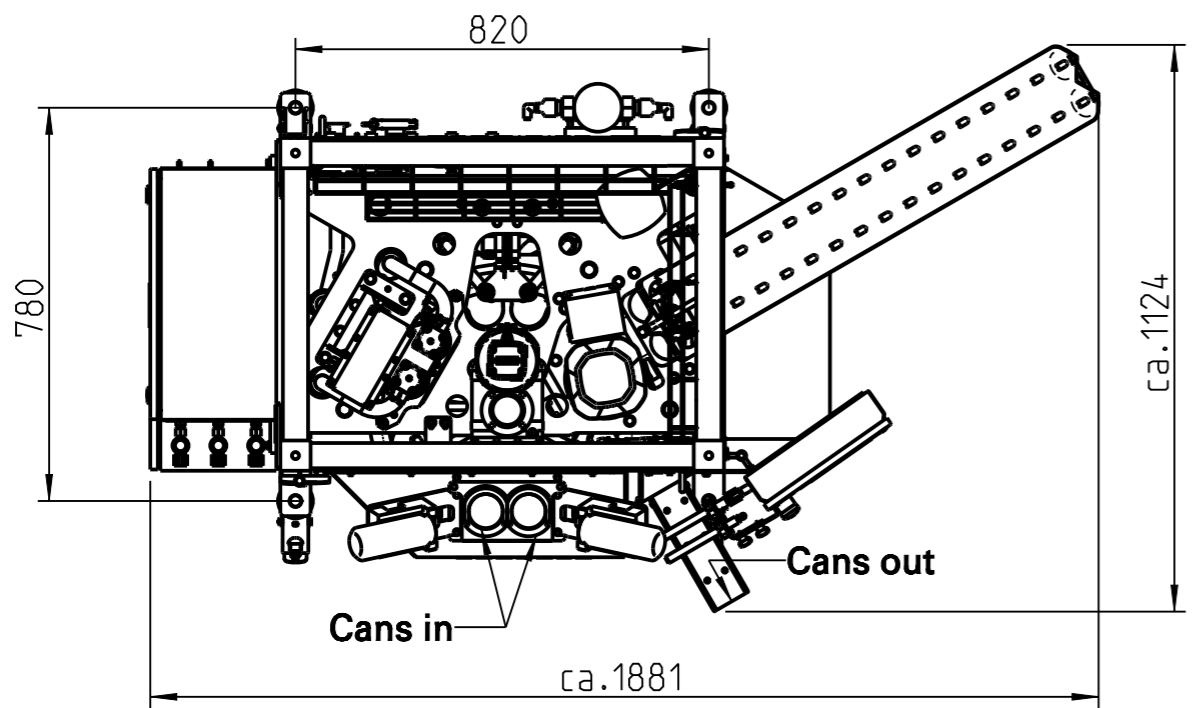
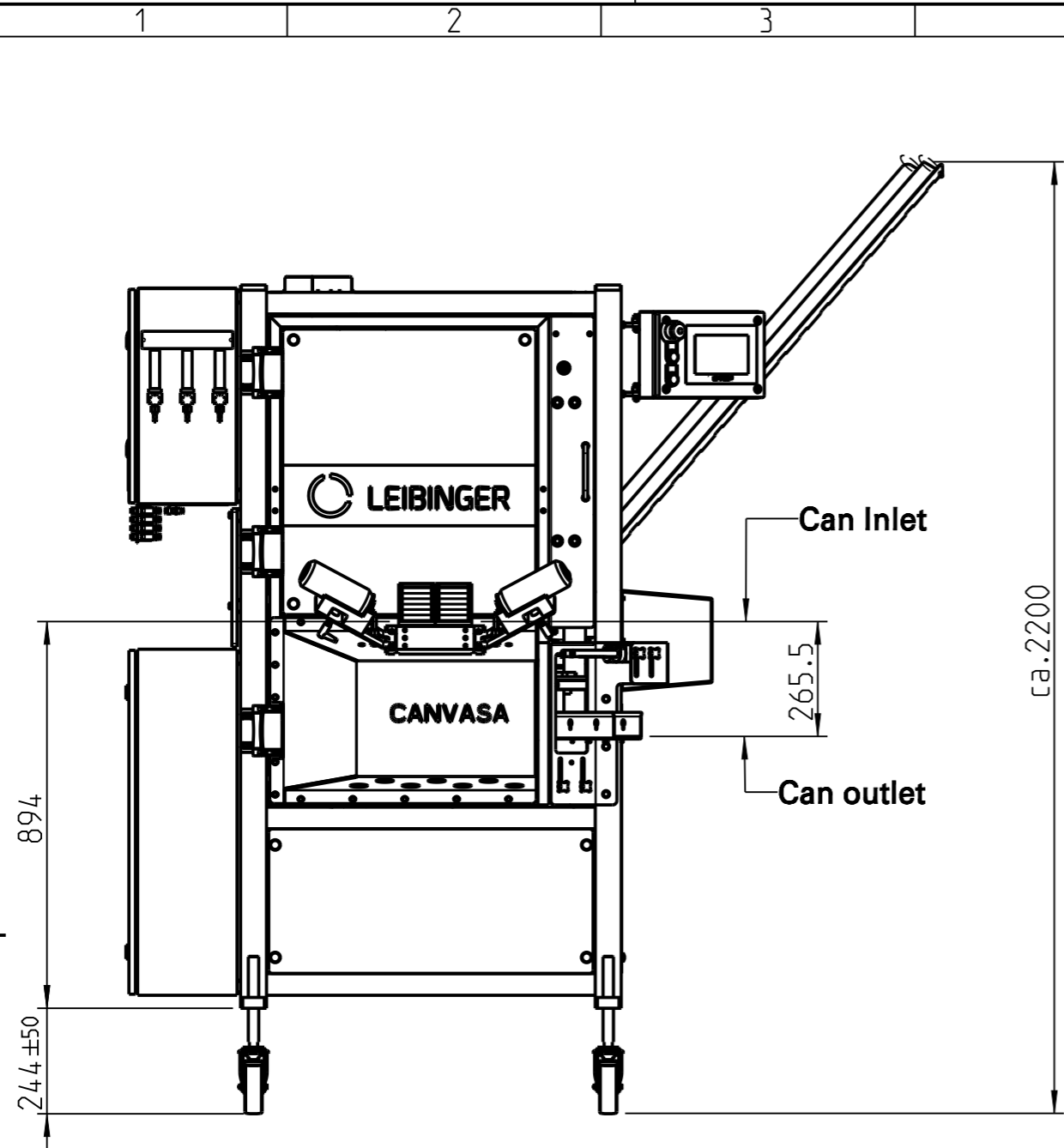

>0.5-6	±0.1	Allgemeintoleranzen/ general tolerances DIN ISO 2768 mK
>6-30	±0.2	
>30-120	±0.3	
>120-315	±0.5	
>315-1000	±0.8	
>1000-2000	±1.2	
>2000-4000	±2.0	
Index	Name	Datum

Maßstab / scale: 1:15	Blatt / sheet: 1 - 1
Werkstoff / material:	
Halbzeug / raw material: -	
Benennung / title:	
Datum	Name
gez. 30.11.21	mko
gepr.	
normg.	
Zeichnungsnummer / drawing number:	
M2090-01	



Canvasa II+II
dimensional drawing

M2090-01