

Eigentum der Firma Leibinger GmbH 79331 Teningen. Vervielfältigung, sowie jede mißbräuchliche Verwendung, insbesondere Überlassung an Dritte oder Verwendung zu anderen als dem vereinbarten Zweck, berechtigt zur Forderung von Schadenersatz.

Property of company Leibinger GmbH 79331 Teningen. Reproduction as well as any misuse particular transfer to third parties or use to other than the purpose agreed entitled to claim damages.

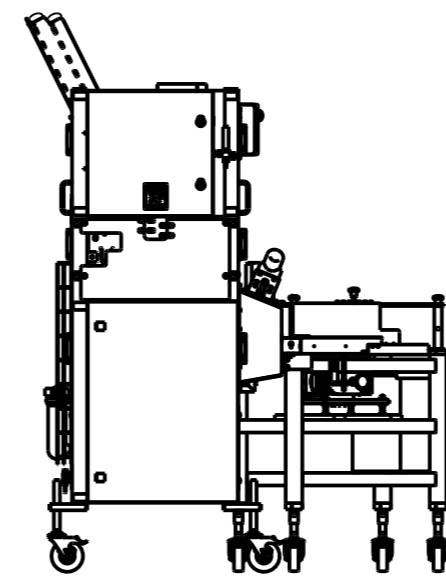
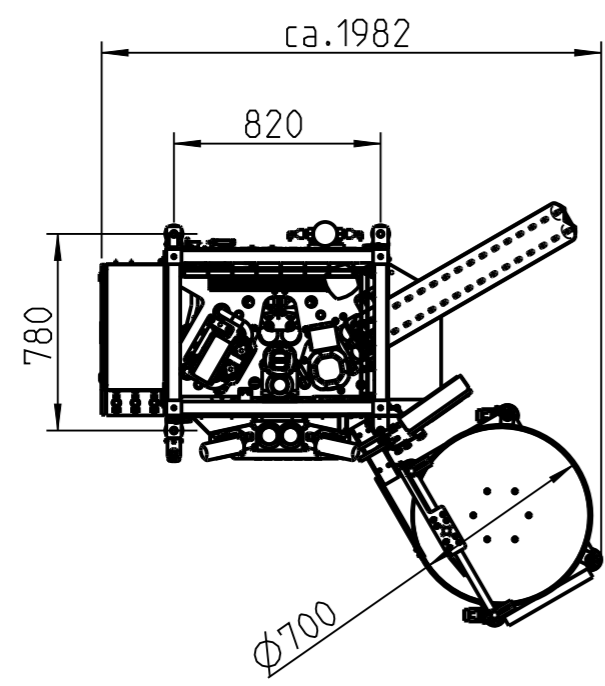
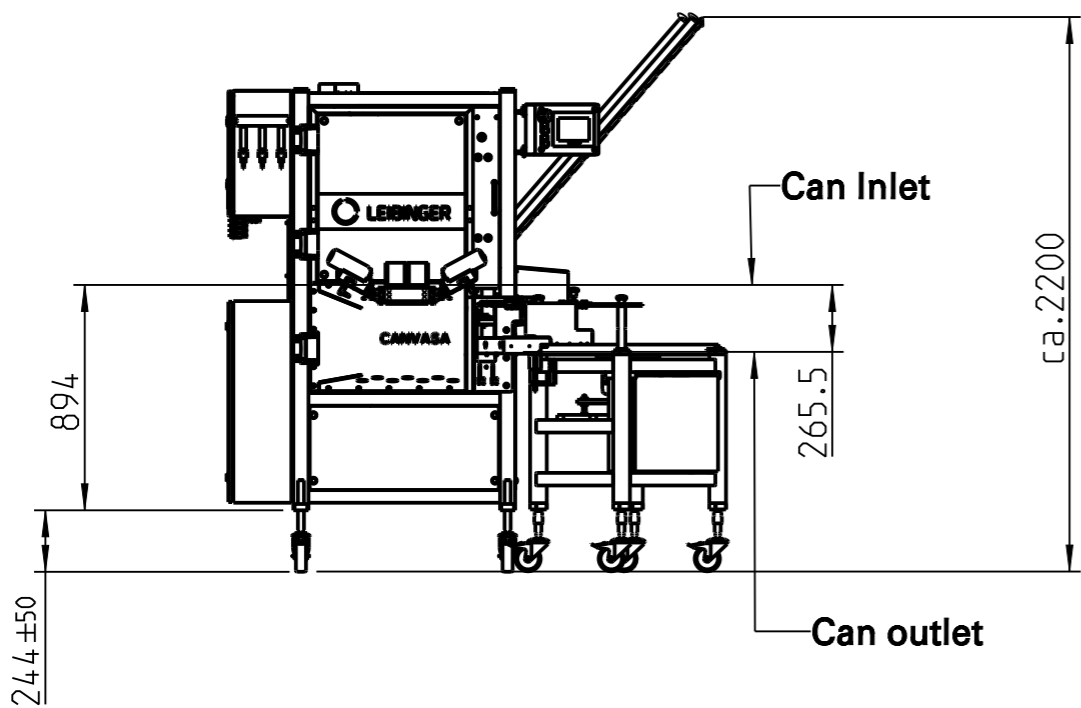

Compressed air inlet: G3/8"  
Rinser inlet: G3/8"  
CO2 inlet: G3/8"  
Water inlet: G3/8"

Product inlet  
CIP inlet  
DN32 DIN37676-A Tri Clamp  
CIP outlet  
DN25 DIN37676-A Tri Clamp  
Electrical connections

Weights:  
Canvasa: 500kg  
turntable: 140kg

>0.5-6	±0.1	Allgemeintoleranzen/ general tolerances DIN ISO 2768 mK
>6-30	±0.2	
>30-120	±0.3	
>120-315	±0.5	
>315-1000	±0.8	
>1000-2000	±1.2	
>2000-4000	±2.0	
Index	Name	Datum

Maßstab / scale: 1:30	Blatt / sheet: 1 - 1
Werkstoff / material:	
Halbzeug / raw material: -	
DIN ISO 128-30	Benennung / title:
	CANVASA II+II with turntable
Datum	Name
gez. 25.01.22	mko
gepr.	
normg.	
Zeichnungsnummer / drawing number: M2093-01	

