

Balcony glazing
installation
standard of
Malmerk Klaasium

Glazing system and components

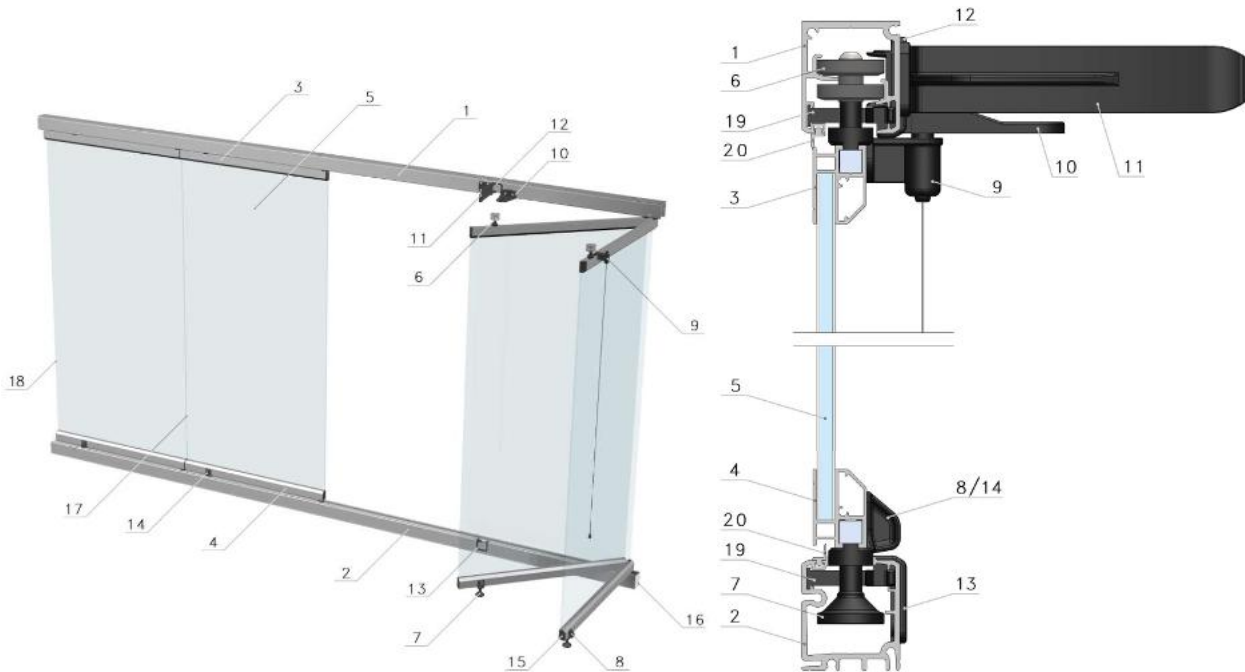

1	Upper steering profile
2	Lower steering profile
3	Upper glass panel profile
4	Lower glass panel profile
5	Glass panel
6	Upper opening rollers
7	Lower opening roller
8	Lower opening latch
9	Ventilation positioner
10	Ventilation position holder

11	Roller support
12	Upper opening-hole cover
13	Lower opening-hole cover
14	Opening handle
15	Glass panel profile end cap
16	Bottom steering profile end-plate/cap
17	Optional weather strip between glass panel
18	Optional weather strip to walls
19	Hinge rod
20	Silicone gasket



The order of the work operations

1. Preparation	4
1.1. Documents required, picking of the goods and delivery to the site	4
1.2. Appointment with the customer	4
1.3. Securing the safety equipment	4
1.4. Checking the installation surface and marking the position of the steering profiles	4
1.5. Removing obstacles from the installation surface and cleaning the installation surface.....	4
1.6. Delivery of steering profiles, drip caps and glazing modules to the site	5
1.7. Marking the fastening holes for the upper steering profile	5
1.8. Checking the thickness of the upper installation surface and drilling fastening holes for the upper steering profile.....	5
2. Installation of the upper drip cap	6
2.1. Cutting the upper drip cap in size	6
2.2. Drilling the fastening holes for the upper drip cap	6
2.3. Sealing the upper drip cap with silicone	6
2.4. Mounting the upper drip cap on the upper installation surface.....	6
3. Installing the steering profiles	7
3.1. Preliminary installation of the upper steering profile and the adjustment profile	7
3.2. Levelling and securing the upper steering profile and the adjustment profile	7
3.3. Adjusting the upper steering profile in the adjustment profile	7
3.4. Preliminary installation of the lower steering profile.....	8
3.5. Preliminary installation of glass panels between the steering profiles	8
3.6. Fixing the position of the lower steering profile	9
3.7. Adjusting the lower steering profile.....	10
4. Positioning glass panels between steering profiles	10
4.1. Tighten the roller bolts and the fixing screws of roller heels	10
4.2. Positioning the first opening panel	11
4.3. Fixing the upper hinge rod.....	11
4.4. Fixing the lower hinge rod	12
5. Installation of plastic details – opening hole covers, roller support and ventilation position holder	12
6. Adjusting and fixing the opening rollers of glass panels	13
7. Positioning the stopper of the last sliding glass panel	13
8. Positioning the lower drip cap	14
8.1. Cutting and bending the lower drip cap	14
8.2. Fixing the lower drip cap.....	15
9. Final fixing of the lower steering profile	15
10. Finishing with fillers	15
10.1. Sealing with silicone	15
10.2. Filling with montage foam	16
11. Installation of the glass panel holder on the wall	16
12. Installing weather strips between glass panels and at ends	17
13. Delivery of the work to the customer	17



1. Preparation

1.1. Documents required, picking of the goods and delivery to the site

Documents received from the Installation Manager:

- Instrument of delivery and receipt
- Measurement sheet
- If necessary: coordination drawings, work drawings, installation drawings

When picking the goods, ensure that all products in the order list are picked and that they correspond to the dimensions indicated in the order.

For delivery, place the glazing modules on the required rack edgeways and secure them with padding material (1). Steering profiles, weather strips and other necessary details for installation shall be placed in the vehicle so that they cannot move freely or be damaged.

1.2. Appointment with the customer

The time of installation has been agreed in advance between the customer and the Installation Manager. It is good practice to notify the customer if you are late to the appointment with the customer.

The first appointment with the customer does not include delivery of any goods to the site; inspect the site visually and ensure that the work can be performed safely and without problems (2).

1.3. Securing the safety equipment

Depending on the site, use of safety equipment may be necessary. Agree on the fastening point for the safety line of the safety harness with the customer and secure the safety line of the safety harness. If you need to drill a hole on the balcony for the fastening anchor, always notify the customer of that. Cover the drilled hole with silicone at the end of the installation.

1.4. Checking the installation surface and marking the position of the steering profiles

Perform a reference measurement of the installation surfaces and ensure that the system is suitable for the site. Choose the position of the upper steering profile, ensuring that there is sufficient fastening area on the upper installation surface and that vertical levelling indicates that fixing of the lower steering profile is ensured. Mark the position of the upper steering profile on the installation surface (3, 4, 5).

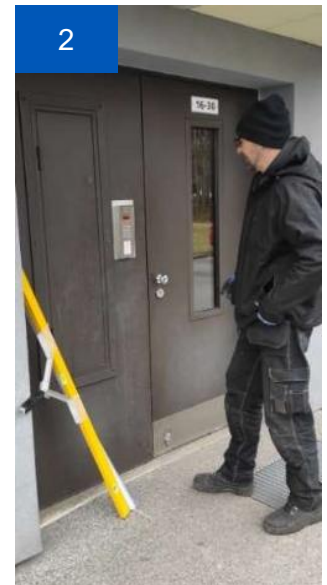

1.5. Removing obstacles from the installation surface and cleaning the installation surface

If necessary, remove details that may hinder installation from the installation surfaces. Ensure that their removal will not damage the building structure or the look of the facade. Clean the surface under the upper steering

profile from dust, dirt and grease to ensure the adhesion of the silicone adhesive between the upper drip cap and the installation surface.

Note! This ensures that rainwater cannot run onto the balcony from the balcony above. Subsequent amending of this error is complicated and time-consuming.

1.6. Delivery of steering profiles, drip caps and glazing modules to the site

Deliver the steering profiles, drip caps and glass panels to the site, ensuring that the materials or the walls of the building or apartment are not damaged.

1.7. Marking the fastening holes for the upper steering profile

Open the packaging of the steering profile carefully. **Note!** Avoid damaging the paint finishing of the steering profiles when opening the package (6). Cut off the excess part of the steering profile seal (7). Position the upper steering profile on the upper installation surface, observing the previously marked positioning points (8), and mark the positions of fastening bolts of the steering profile through the fastening holes in the steering profile (9).



Ensure that the hinge rods of the steering profiles are positioned on the opening side as indicated in the figure (Figure 1)

1.8. Checking the thickness of the upper installation surface and drilling fastening holes for the upper steering profile

Check the thickness of the upper installation surface to avoid drilling through it (10). Mark the drilling depth on the stone drill that will be used to drill the fastening holes for the upper steering profile (11). The depth marked on the drill shall be lower than the depth of the upper installation surface. Drill the fastening holes for the upper profile with a stone drill, observing the markings. Ensure that the drill is not inserted deeper than the marking made on the drill (12).

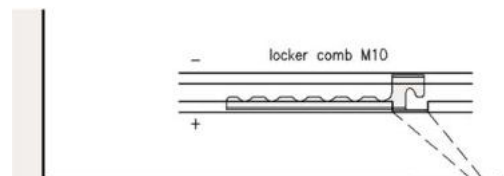
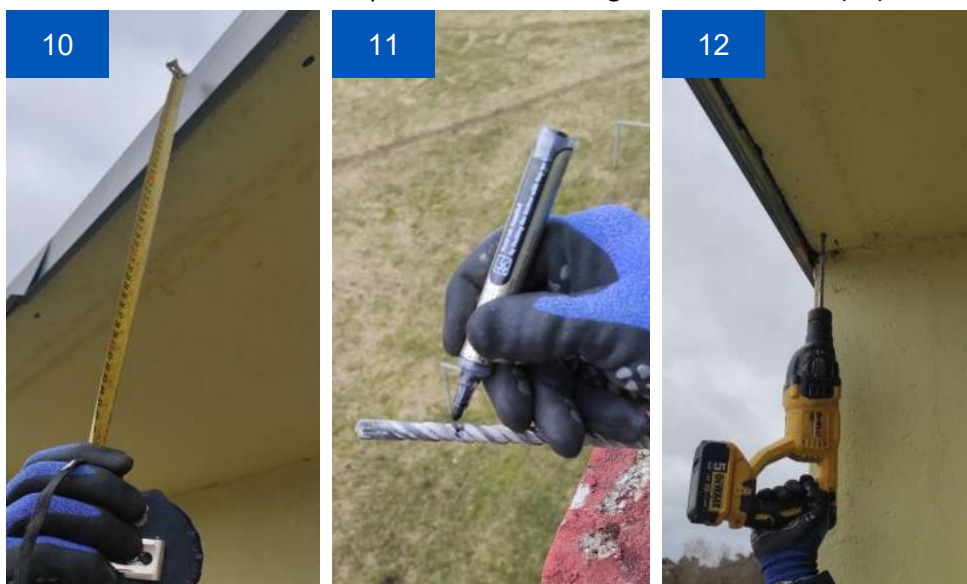

Figure 1



2. Installation of the upper drip cap

2.1. Cutting the upper drip cap in size

Mark the cuts for the facade on the upper drip cap (13, 14) and make the cuts using plate shears (15).

The inner edge of the upper drip cap should be positioned outside the fastening holes of the upper profile (Image 16 indicates the final result after installation).

Note! Never use an angle grinder for cutting, this damages the zinc surface of the galvanised plate and leads to quick corrosion of the plate!



2.2. Drilling the fastening holes for the upper drip cap

Using a 6 mm metal drill, drill holes for the nail dowels in the upper drip cap, approx. 10-15 mm from the drip cap edge (17). Place the drip cap in the installation position on the upper installation surface, ensuring that it covers the fastening holes of the upper steering profile, and drill holes for the nail dowels through the holes in the drip cap, using a stone drill (18).

2.3. Sealing the upper drip cap with silicone

Using a silicone gun, apply a strip of silicone on the outer bend of the fixing surface of the upper drip cap which is in contact with the balcony ceiling. Use a sufficient amount of silicone to fill all irregularities on the upper surface and stop the ingress of water from the drip cap to the upper steering profile and from there to the balcony (19, 20).



2.4. Mounting the upper drip cap on the upper installation surface

Place the upper drip cap in the correct position on the upper installation surface and insert the nail dowels through the fastening holes. Tap the nail dowels in place using a hammer (Image 16 indicates the final result after installation).

Note! If necessary, apply more silicone to fill any irregularities on the drip cap and the upper installation surface.



3. Installing the steering profiles

3.1. Preliminary installation of the upper steering profile and the adjustment profile

Place the upper steering profile or the adjustment profile on the upper installation surface, aligning it with the pre-drilled fastening holes, and secure the steering profile in the middle with a brass anchor (21). Do not tighten the brass anchor completely, just enough to hold it in place in the hole and keep the steering profile from sinking down (22). Repeat with all remaining fastening holes. Position a 2 mm wedge at the fastening point nearest to the upper installation surface and tighten the fastening bolt in the brass anchor completely.

Note! If necessary, drill new fastening holes in the steering profile to secure the steering profile. Never use an impact drill to tighten the screws.



3.2. Levelling and securing the upper steering profile and the adjustment profile

Check the horizontal (23) and vertical (24) levelling of the upper steering profile or the adjustment profile, using a level. If necessary, use wedges for levelling (25).

Tighten the fastening bolts in brass anchors completely (26).



3.3. Adjusting the upper steering profile in the adjustment profile

Adjust the steering profile positioned inside the adjustment profile, taking into account that the steering profile can be moved 21 mm down from the highest position in the adjustment profile.

3.3.1. Adjustment profile with standard configuration

The distance between the upper edge of the standard adjustment profile and the lower edge of the steering profile is 84mm in the highest position (27). In the lowest position, the distance between the upper edge of the adjustment profile and the lower edge of the steering profile must not exceed 105 mm (28). If this limit is exceeded, there is risk that the stopper screws of the adjustment profile cannot be secured and the upper edge of the steering profile becomes visible through the hole cut in the adjustment profile (31).

3.3.2. Adjustment profile with longer configuration

The distance between the upper edge of the longer adjustment profile and the lower edge of the steering profile is 104 mm in the highest position (29). In the lowest position, the distance between the upper edge of the adjustment profile and the lower edge of the steering profile must not exceed 125 mm (30). If this limit is exceeded, there is risk that the stopper screws of the adjustment profile cannot be secured and the upper edge of the steering profile becomes visible through the hole cut in the adjustment profile (31).

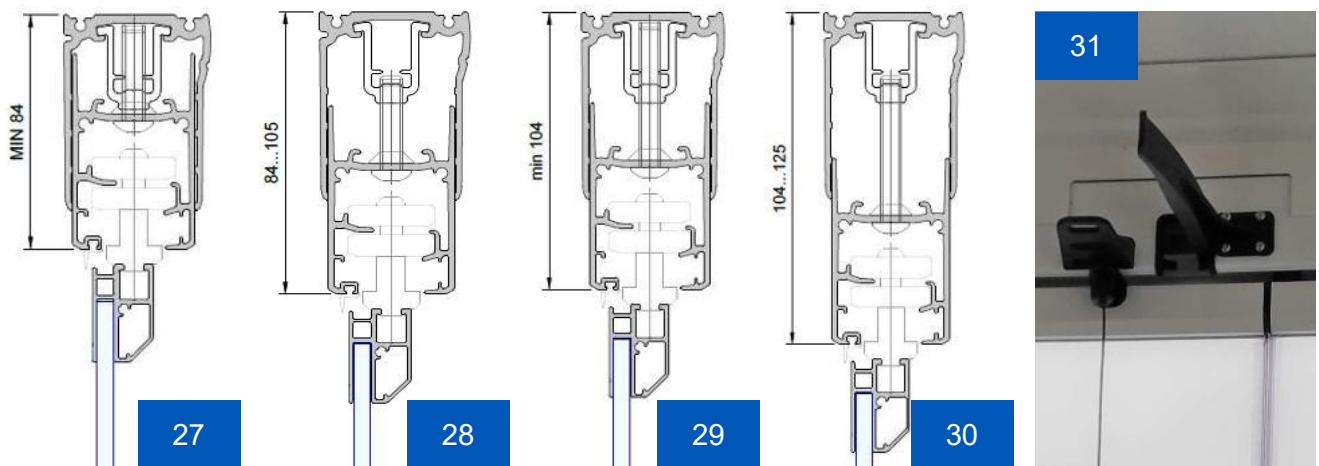

3.4. Preliminary installation of the lower steering profile

Position the lower steering profile on the balcony railing and remove excess profile seal from the ends (32).

3.5. Preliminary installation of glass panels between the steering profiles

Release the opening rollers of all glass panels to enable adjustment of their position (33).

Lift one intermediate sliding glass panel into the upper steering profile so that only the opening roller moves into the steering profile via the steering profile opening (34). While the glass is hanging from the upper opening roller, lift up the lower steering profile and insert the lower opening roller of the same glass panel into the steering profile via the opening hole (35). Slide the glass forward in the steering profiles to enable inserting of the hinge rollers through the holes. Repeat with the other sliding glass panel. Do not place any more glass panels between the steering profiles until the position of the lower steering profile is fixed.

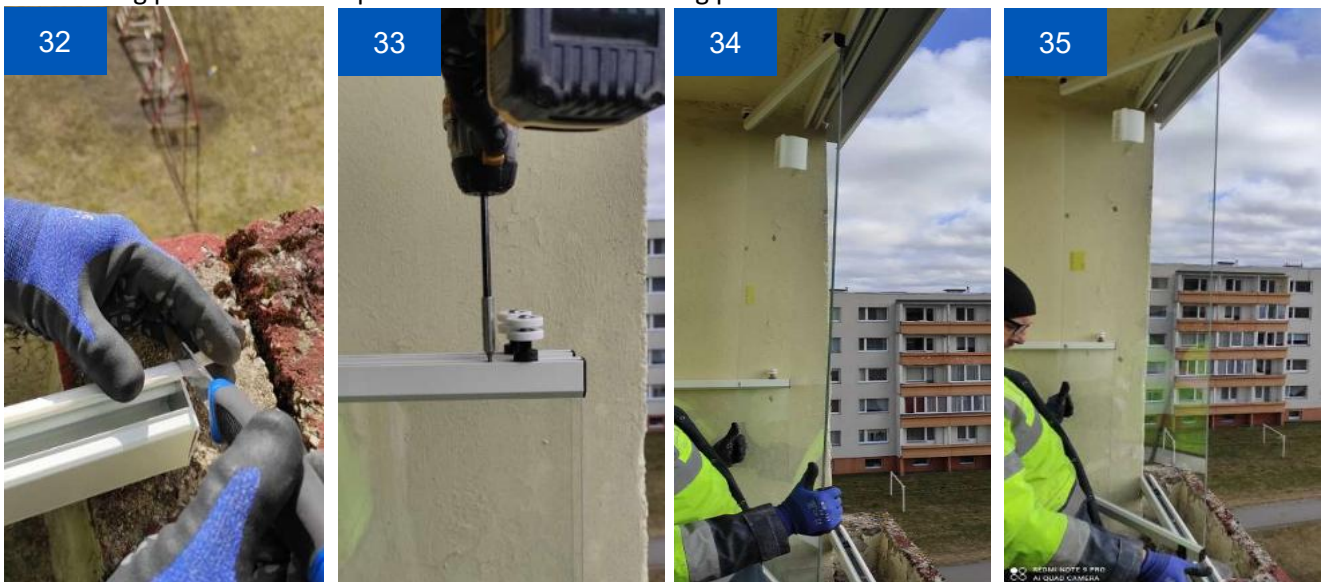

3.6. Fixing the position of the lower steering profile

Mark the position of the lower steering profile, taking into account the vertical and horizontal levelling (36, 37). Prepare the corner angles and cut off excess parts if necessary (38).

Note! Avoid exposing glass surfaces and any inflammable materials to cutting sparks (39).



Using a self-drilling screw, screw the fastening angles of the steering profile ends onto the steering profile from inside the profile (40) with fastening screws with sealing washers.

Secure the fastening angles of the steering profile ends onto the wall, using fastening details suitable for the specific wall (41). Secure the middle fastening angles of the steering profile, using fastening details suitable for the specific fastening surface (42).

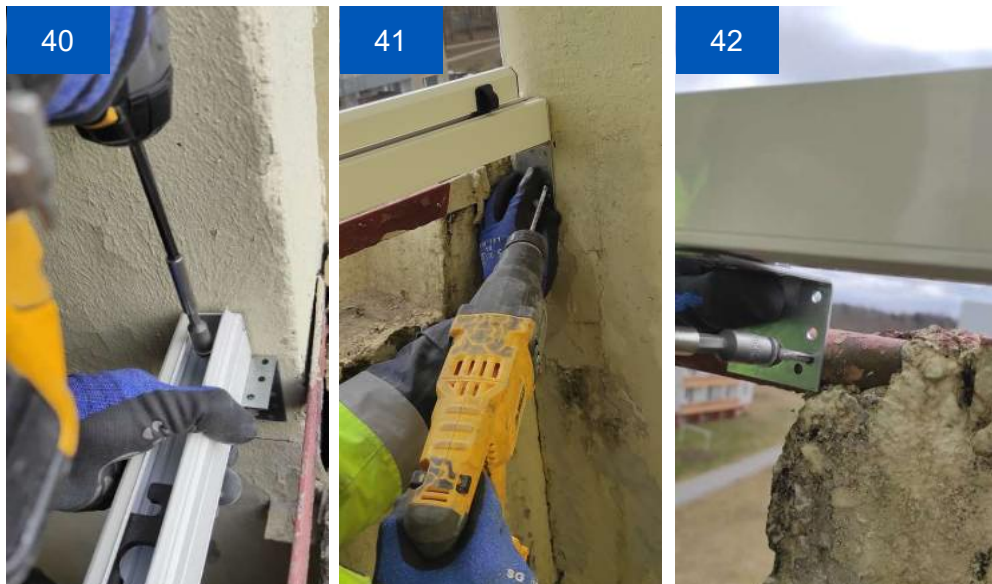

Follow the steps in Figure 2 for the corner joint of the lower steering profile.

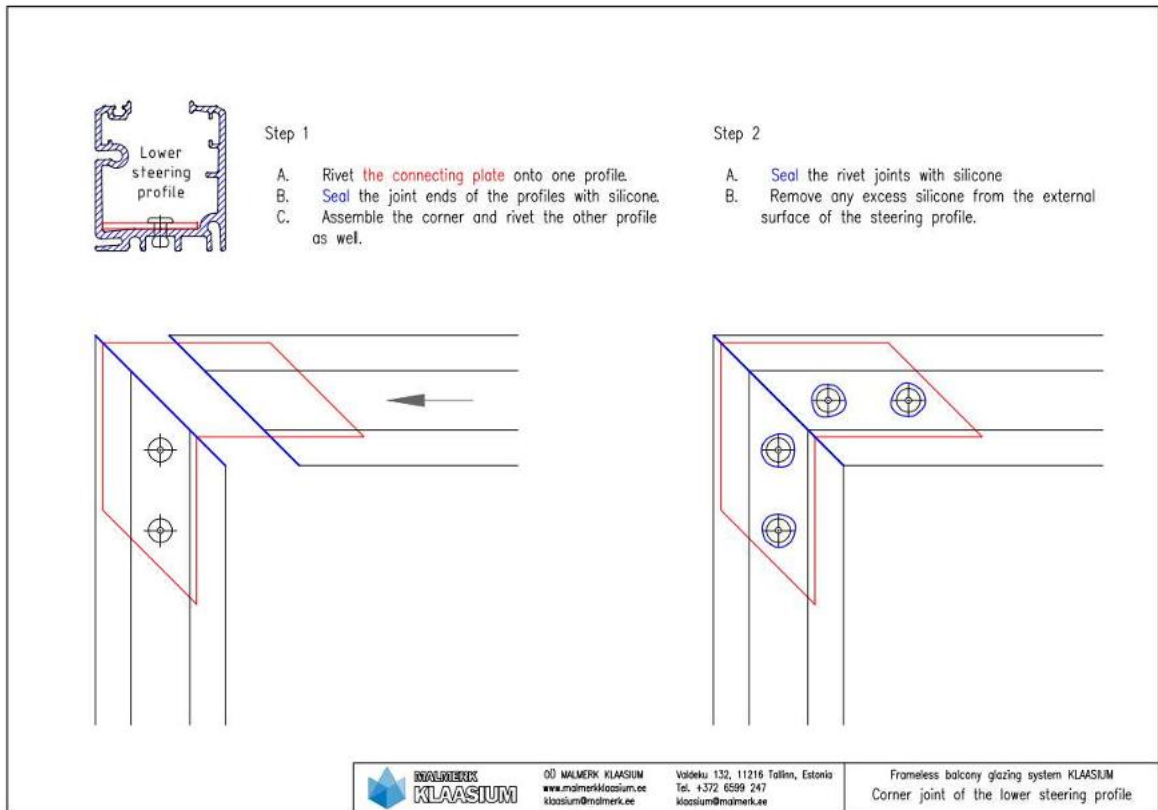

Figure 2

3.7. Adjusting the lower steering profile

Use wedges to adjust the horizontal and vertical levelling of the lower steering profile (43). In order to check the position of the steering profile, move the two glass panels positioned between the steering profiles. The glass panels must move freely.

Note! The distance between the lower steering profile and the glass panel profile shall be 3 mm.

Note! No light may be visible between the weather strip and the glass panel profile.

4. Positioning glass panels between steering profiles

4.1. Tighten the roller bolts and the fixing screws of roller heels

Prior to positioning the glass panels, tighten all lower and upper hinge roller bolts on the hinge side and the fixing screw carefully (Figure 3).

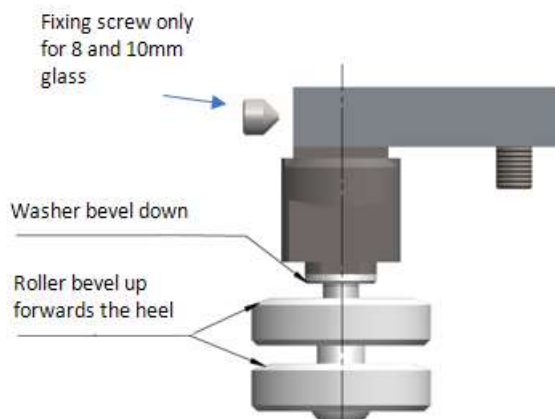

Figure 3



4.2. Positioning the first opening panel

Slide the upper and lower hinge rods into the opening hole so that the hinge roller of the first opening glass panel can be placed into the slot for the opening glass in the hinge rod (44).

Remove the hinge roller of the first opening glass panel and position the ventilation lock onto the glass panel profile (45).

Position the opening roller of the first opening glass panel back in its place (46).



Position the upper and lower hinge rollers of the first opening glass panel in the slots in the hinge rod (47, 48) and slide the hinge rods with the glass panel to the end of the steering profile.

Position a 3 mm wedge at the opening side of the first opening glass panel, between the lower steering profile and the glass panel profile (49).

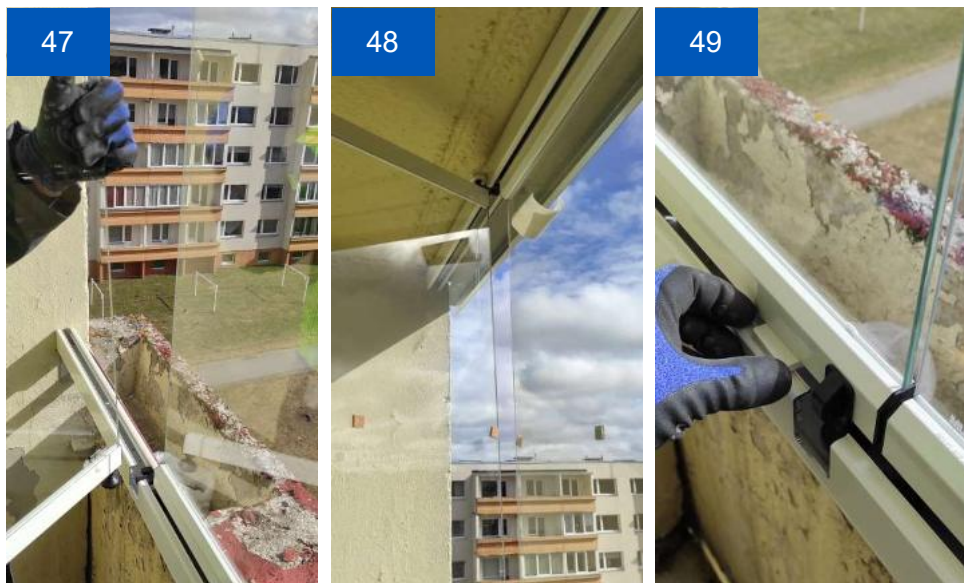

4.3. Fixing the upper hinge rod

Position all remaining glass panels between the steering profiles. Ensure that the distance between the both side walls and the glass panels is even when positioning the glass panels in the balcony opening (50, 51).

Drill a hole for the hinge rod fixing screw through the upper steering profile, using a 3.2 mm metal drill (52), and secure the upper hinge rod with a 3.8x16 stainless Torx screw (53).

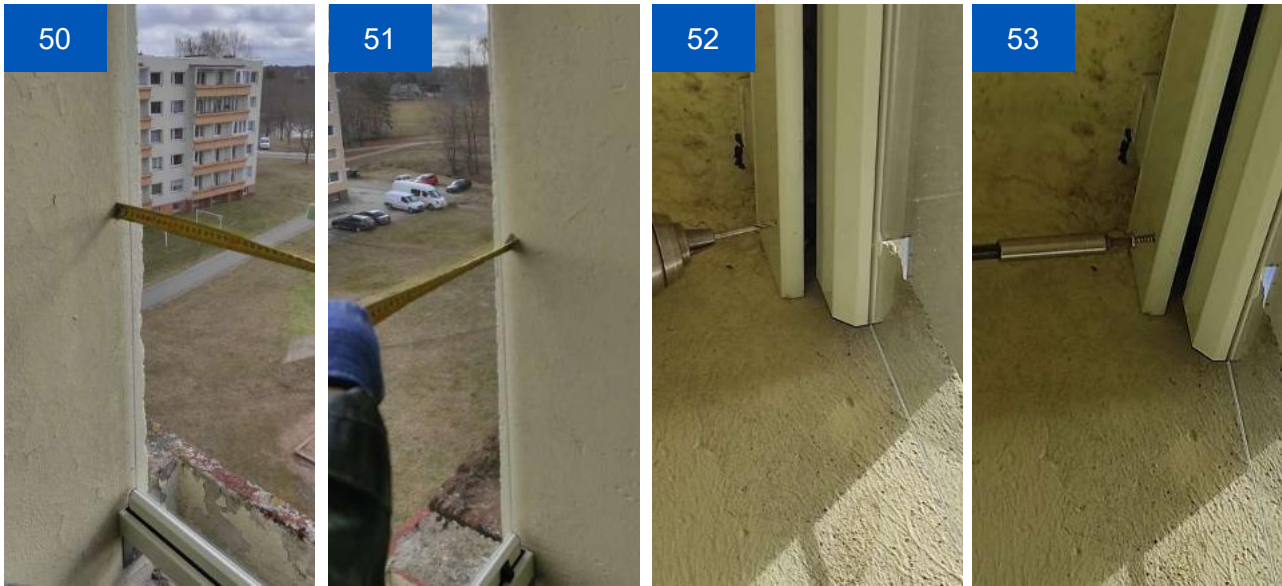

4.4. Fixing the lower hinge rod

Open the first opening glass panel and slide the second sliding glass panel to the opening position but without opening it (54, 55). Slide the lower hinge rod to a position where the distance between the first open glass panel and the edge of the sliding glass panel is equal above and below. This position ensures that the upper and the lower hinge roller of the sliding glass panel enter the hinge rod simultaneously and the glass panels can be opened without problems.

Fix the lower hinge rod, following the steps described in section 4.3 for fixing of the upper hinge rod.

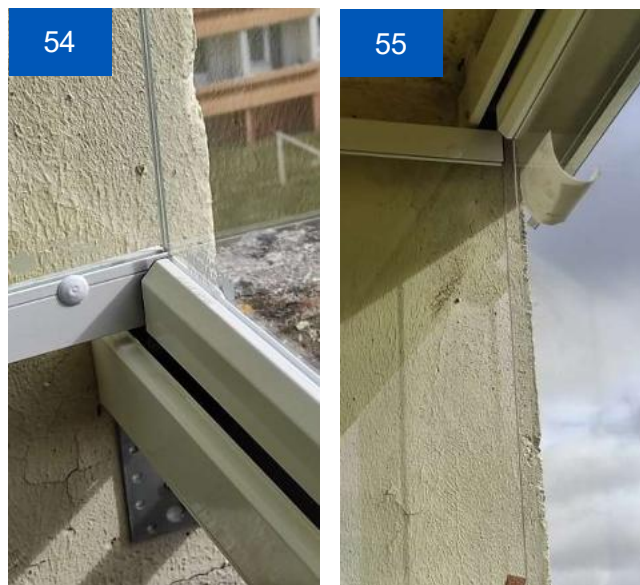

5. Installation of plastic details – opening hole covers, roller support and ventilation position holder

Install the opening hole covers (56). The higher opening hole cover is intended for the upper steering profile and the lower opening hole cover for the lower steering profile (57).

The upper steering profile has pre-drilled screw holes for the roller support and the ventilation position holder. Fix the roller support (58) and the ventilation position holder (59) with 3.8x16 stainless Torx screws.

Note! While opening and closing glass panels, ensure that the opening rollers enter the roller support in the correct position. If necessary, adjust the angle of the roller support with a 1 mm wedge.



6. Adjusting and fixing the opening rollers of glass panels

While opening and closing the glass panels, adjust and fix the lower opening rollers using a hex key (60, 61). While opening and closing the glass panels, adjust and fix the upper opening rollers using a hex key (62, 63).

Note! While adjusting opening rollers, remember to also re-tighten the fixing screw of the roller heel after fixing the position (Figure 3).



7. Positioning the stopper of the last sliding glass panel

Remove the lower opening hole cover. Insert the stopper piece through the hole (64) and slide it to the end of the lower steering profile. Close all glass panels and mark the position of the stopper. Open the glass panels again. Using a 3.2 mm drill, drill a hole for the fastening screw into the outer side of the lower steering profile (65) and fix the stopper with a 3.8x16 stainless Torx screw.

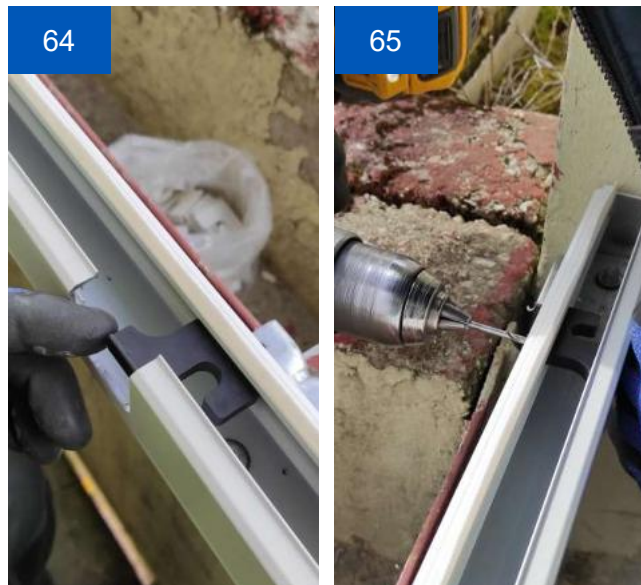

8. Positioning the lower drip cap

8.1. Cutting and bending the lower drip cap

Measure and mark the cutting positions on the lower drip cap and cut them (66, 67, 68).

Note! Never use an angle grinder. Cutting with an angle grinder damages the zinc surface of the galvanised plate and leads to quick corrosion of the plate.

Bend the corners of the lower drip cap that connect to the wall (69, 70, 71).



8.2. Fixing the lower drip cap

Position the drip cap in the drip cap groove on the lower steering profile. Using a 3.2 mm drill, drill rivet holes into the drip cap and the lower steering profile (72). Fix the drip cap with 3.2 mm blind rivets, using riveting tongs (73, 74).



9. Final fixing of the lower steering profile

If necessary, adjust the lower steering profile with wedges. When you are sure that the position is correct, cut off the excess protruding ends of self-drilling screws (75, 76).

Note! Leave no sharp edges that may cause injuries in case of contact.

Note! Avoid exposing glass surfaces and inflammable materials to cutting sparks.

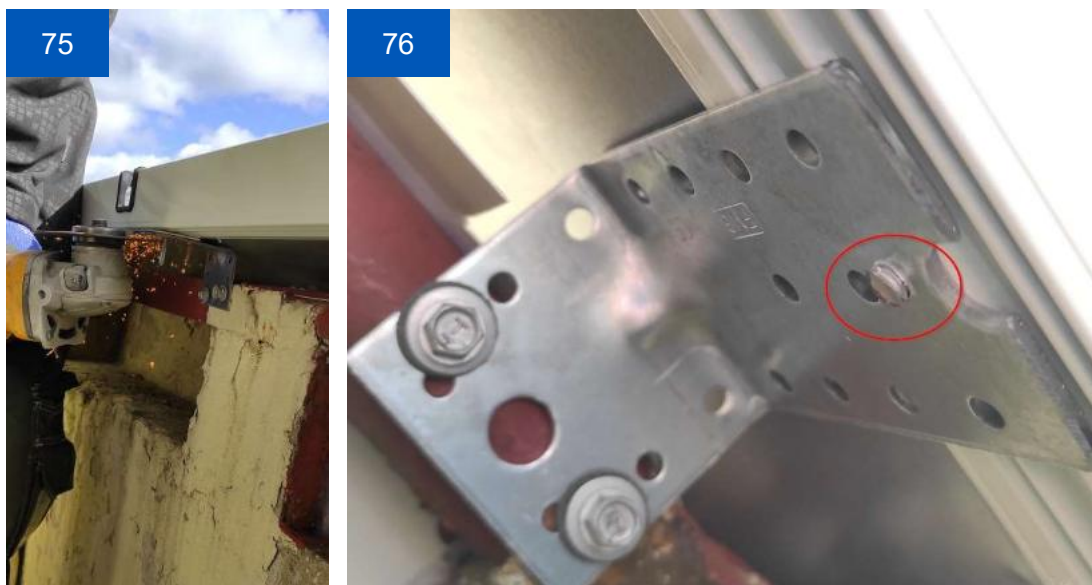

10. Finishing with fillers

10.1. Sealing with silicone

Fill the following places with silicone:

- the lower drip cap and rivet heads (77)
- the ends of the lower and upper steering profile, both on the inner and the outer side (78, 79)
- the parts of the lower and upper drip cap connecting to the wall (80).



10.2. Filling with montage foam

Fill the space between the upper steering profile and the installation surface with montage foam (81).
Fill the space between the lower steering profile and the installation surface with montage foam (82).

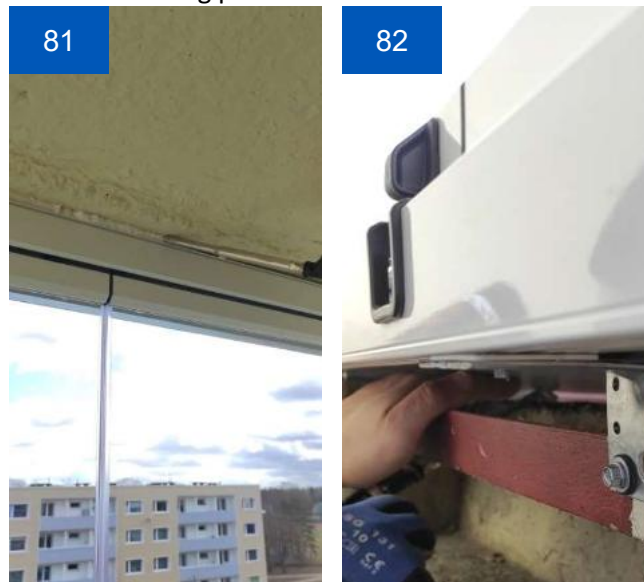

11. Installation of the glass panel holder on the wall

Using a stone drill, drill a hole for the wall holder hook into the wall on the opening side of the glass panels, at the height of the rollers (83). Position an anchor in the hole (84) and install the glass holder onto the wall (85).

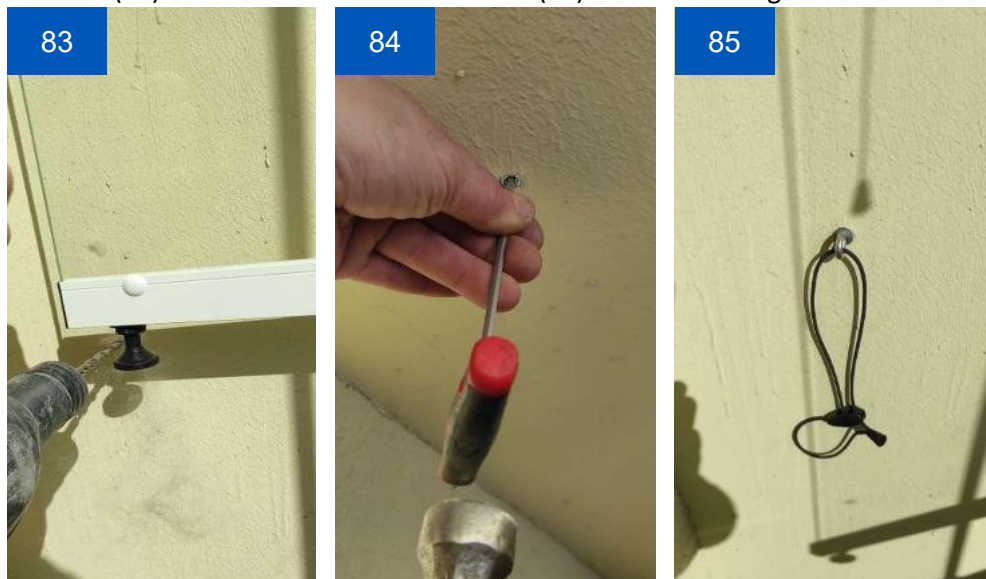

12. Installing weather strips between glass panels and at ends

If the customer has ordered weather strips between or at the ends of glass panels, install those.

- In case of 6 mm glass, all weather strips are installed on the hinge side. In case of a long balcony which opens in both directions, one of the glass panels sliding together in the middle is surrounded with weather strips between glass panels on both sides.
- In case of 8 mm and 10 mm glass panels, all weather strips between glass panels are installed on the opening side of the glass panels, not on the hinge side. The first sliding glass panel is an exception. On this, the weather strips are installed on both sides. In case of a long balcony with 8 mm and 10 mm glass panels where the panels are opened in both directions, one of the middle glass panels remains without weather strips. For installing weather strips between glass panels, cut a suitable length of weather strip using an angle grinder and install it on the glass.

Note! The weather strip at the end of an opening glass panel shall be pressed against the wall more!

Measuring, cutting and installing end weather strips – see Figure 4.

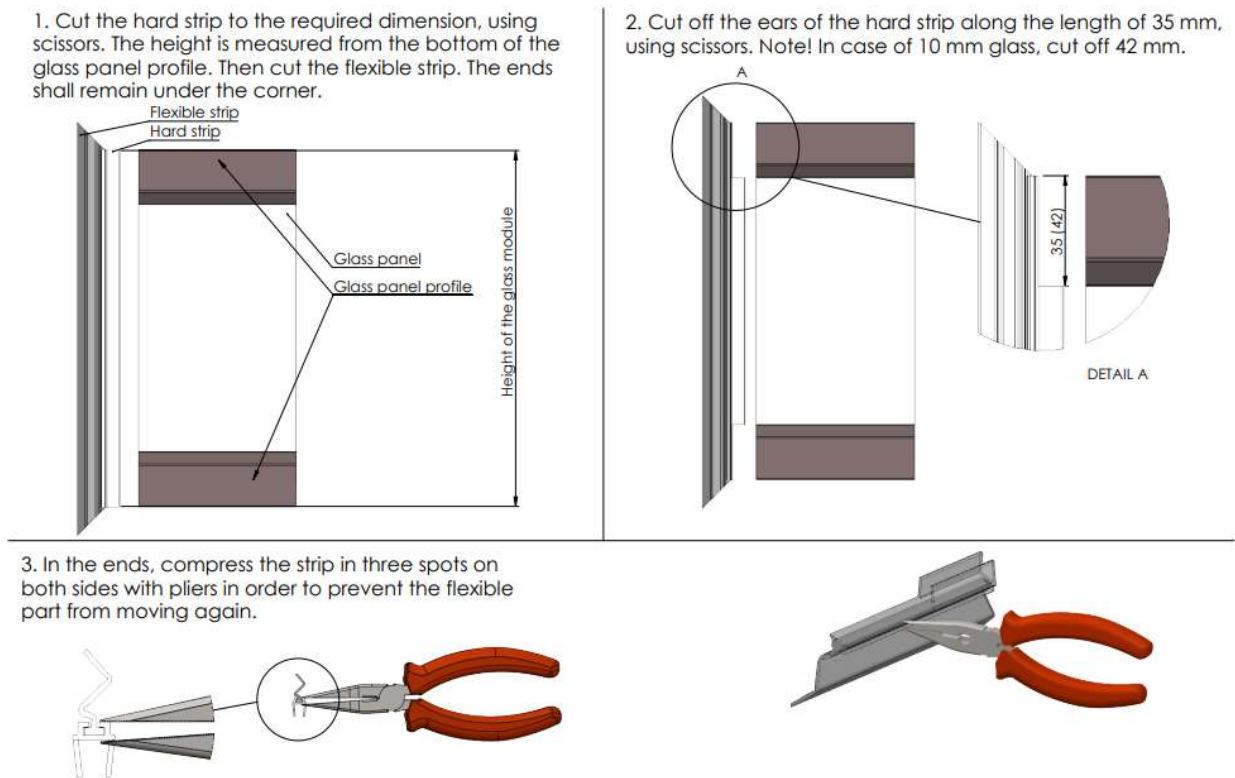

Figure 4

13. Delivery of the work to the customer

- Prior to delivery of the work to the customer, collect your tools and clean up the debris from the installation.
- Explain the working principle of the balcony glazing to the customer and ask the customer to open and close the glass panels a couple of times. Submit the user and maintenance manual of the balcony glazing to the customer and explain the QR code.
- Sign the instrument of delivery and receipt of the work and have it signed by the customer as well. The customer shall keep the copy with the user instructions of the balcony glazing on the reverse. Bring the other copy to the Installation Manager.

Amendments of the manual

Version	Date	Content
1	08.04.2022	New document
2	20.10.2023	Figure 3 change