



MALMERK KLAASIUM

Balcony and terrace glazing

PRODUCT CATALOGUE



Our mission

Transforming outdoor areas into practical, safe, useful and valuable extra spaces.

Our vision

To be the preferred partner offering glass-aluminium balcony and terrace products in the Nordic-Baltic countries.

Our values

Reliable
Forward-thriving
Solution-oriented
Honest & caring

Malmerk Klaasium OÜ main area of activity is the production of glass-aluminium balcony and terrace glazing systems, balcony railing systems, roof constructions and winter gardens. We design and produce the systems according to our customers' needs. Our up-to date processes, experts and long experience guarantee well-functioning, custom, secure and long-lasting solutions.



General information

Malmerk Klaasium has designed a frameless balcony and terrace glazing system that has successfully passed security tests at the VTT Technical Research Centre of Finland and has been granted a CE certificate.

Customizable design

Our frameless balcony and terrace glazing system is specifically made to measure for each balcony and customized based on customer needs – dimensions, colours, opening directions.

Quality materials and controlled processes

Aluminium profiles and system components are designed in-house and produced by quality suppliers.

In-house engineering and production

Every project and installation is approached individually. In some cases, the technical solutions specified in this catalogue may not be applicable. In these cases, the solution to be applied is looked over on a case-by-case basis. All materials and components are delivered ready-assembled, ready for installation on site.

Common design line

Safety glass is always used and aluminium profiles are powder coated according to the RAL catalogue. The system looks modern and clean.

Contents

Model of the balcony glazing system	3
System information	4
Glass panels	4
Profiles	4
Fixings and plastic details	5
Locking of the system	5
Ventilation and insulation	5
Noise control	5
Maintenance	5
Profile information	6
Upper steering profiles and adjustment profiles	6
Upper steering profiles	6
Lower steering profiles	6
Adjustment profiles	7
Glass panel profiles	7
Adjustment range of the system	8
Taking measurements	9
Standard glazing solutions with front-fixed railing	10
Fixing to a front-fixed railing with filling up to handrail	10
Fixing to a front-fixed railing with a gap between the filling and the handrail	11
Standard glazing solutions with top-fixed railing	12
Fixing to a top-fixed railing with filling up to handrail	12
Fixing to a top-fixed railing with a gap between the filling and the handrail	13
Standard glazing solutions with rod railing	14
Handrail-to-ceiling solution	14
Floor-to-ceiling solution	15
Full-height glazing system	16
Recessed system	17
Optional	18
Extras	19
Glass height dimensioning	20
System components	23

Model of the balcony glazing system

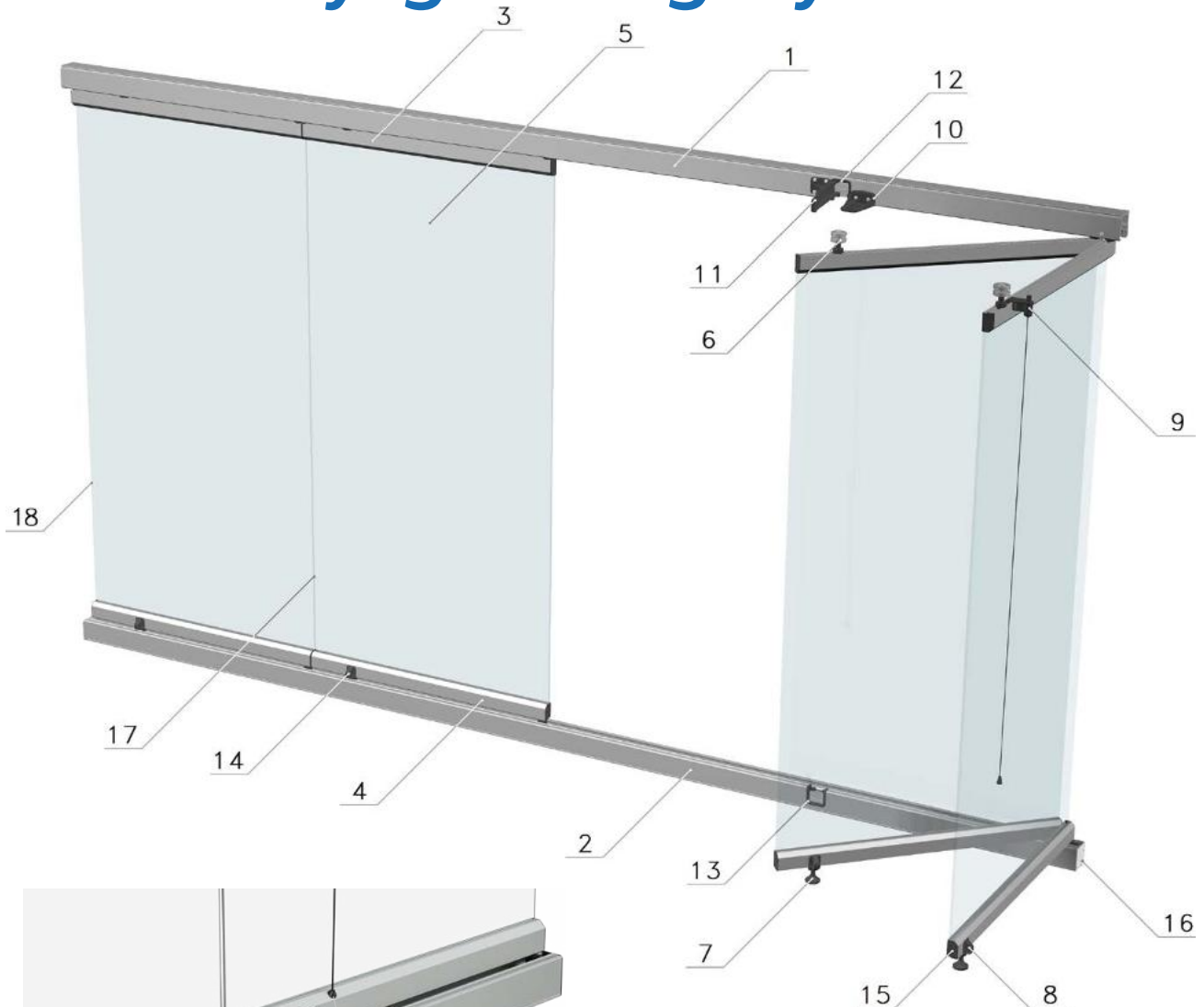

1	Upper steering profile
2	Lower steering profile
3	Upper glass panel profile
4	Lower glass panel profile
5	Glass
6	Upper opening roller
7	Lower opening roller
8	Lower opening latch
9	Ventilation positioner
10	Ventilation position holder
11	Roller support
12	Upper opening-hole cover
13	Lower opening-hole cover
14	Opening handle
15	Glass panel profile end cap
16	Bottom steering profile end-plate/cap
17	Optional weather strip to between glasses
18	Optional weather strip to walls

PROFILES
Aluminium

SURFACE TREATMENT
Powder-coated

COLOUR CHART
RAL

System information

System fully closed



System partly opened



System fully opened



Glass panels

Glass panels are attached to the glass panel profile with four stainless steel rivets and polyurethane glue. The upper glass panel profile is equipped with four ball-bearing rollers and the lower glass panel profile with two sliding rollers. Every panel is equipped with a small plastic opening handle. The glass panels can be opened like pages of a book inside the balcony.

Glass thickness	6, 8 or 10 mm
System max height	6 mm glass max 2000 mm 8 mm glass max 2500 mm 10 mm glass max 3100 mm
Glass type	Tempered with grounded edges
Glass colour	Transparent, bronze, grey or silkscreen printed
Optimum glass panel width	500-700 mm
Minimum glass panel width	220 mm
Opening of the glass panels	Max 7 glasses per opening
Over the corner opening	Over the corner opening is possible depending on the balcony configuration
Gap between the glass panels	2-4 mm (can be closed with PVC weather strips)

Profiles

Material	Aluminium
Max profile length	6000 mm (Balconies that are more than 6 m long must be continued with a new profile)
Surface treatment and colour chart	Powder-coated RAL
Detailed profile information	Page 6-7

Fixings and plastic details

System fixings	Stainless steel (environment class A2 or A4)
Plastic parts	Reinforced and wear-resistant
Fixing to different surfaces (concrete, stone walls, steel, aluminium)	The constructor is responsible for choosing the right fasteners. Distance L given on the section views refers to chosen fasteners specification. If help needed, please contact Malmerk Klaasium

Locking of the system

2-hand system	Lower latch and separate string
1-hand system	Latch and string are connected
Handle (full-height system)	For full-height glazing system, it is possible to add a handle with a lock (see more on page 18)

Ventilation and insulation

Ventilation is provided through the 2-4 mm gaps between the glass panels. It is also possible to set the first glass panel in ventilating position. It is very important to provide sufficient ventilation on the balcony to avoid condensation and excess moisture. Our frameless balcony glazing system is not an airtight system. It does provide protection from external elements (such as rain, snow, etc.), but in certain conditions some rain or snow may enter the balcony through the gaps between the glass panels.



Fixing of the opened glass panels

The balcony glazing system consists of uninsulated profiles and single-layer glass panels. Hence, a glazed balcony is not an extension of a warm living room.

Noise control

Balcony glazing reduces the amount of street noise entering the balcony by an average of 10-14 dB. (Tests of noise resistance: $R_w = 20$ dB (ISO140-4:1998, ISO717-1:2013); $D_w = 10-14$ dB (RIL192-2003)). In order to achieve maximum sound dampening effect, sound transmission through other structures (balcony railing etc.) must be minimized.

Maintenance

All of the cleaning can be done from the balcony. It is easy to wash the glasses from inside when they are in a closed position and from outside when they are opened. The glasses can be washed with regular domestic glass cleaning detergents. The lower steering profile should be cleaned of the accumulated dust and dirt from inside at least once a year. Washing the profiles with a damp cloth is sufficient for external maintenance.

Profile information

Upper steering profiles and adjustment profiles

The Malmerk Klaasium glazing system offers the possibility to install the upper steering profile directly to the ceiling. If adjustment is needed, please use wedges to level the steering profile. Using wedges may lead to a need of decorative cover profiles, hence we recommend using U- or F-adjustment profiles for easy adjustment and clean finish. The standard adjustment range is 21 mm, which can be extended to 41 mm. For extreme cases, it can be up to 51 mm.

Upper steering profiles

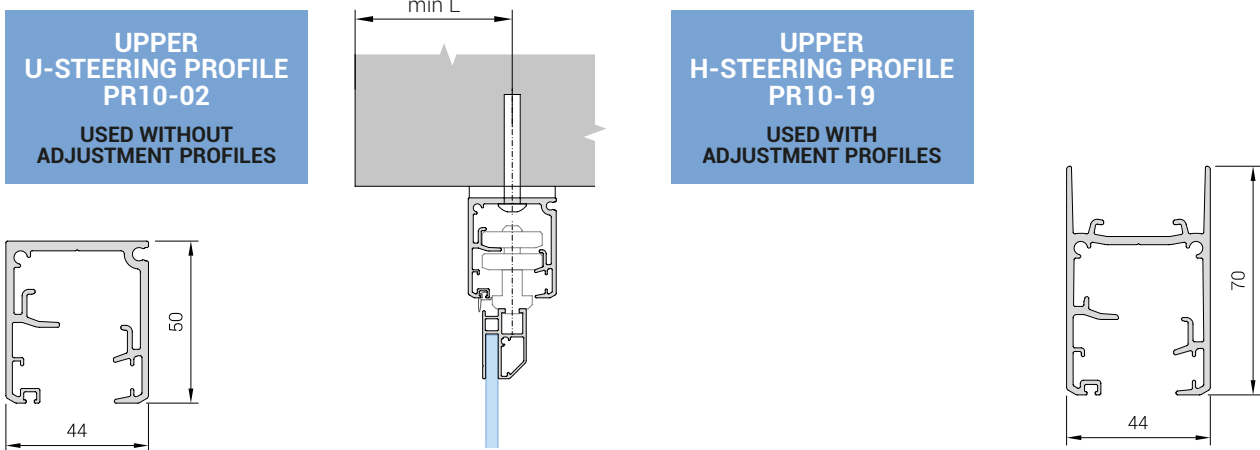

Lower steering profiles

Malmerk Klaasium has two lower steering profiles - for fixing from the top and for fixing from the side:

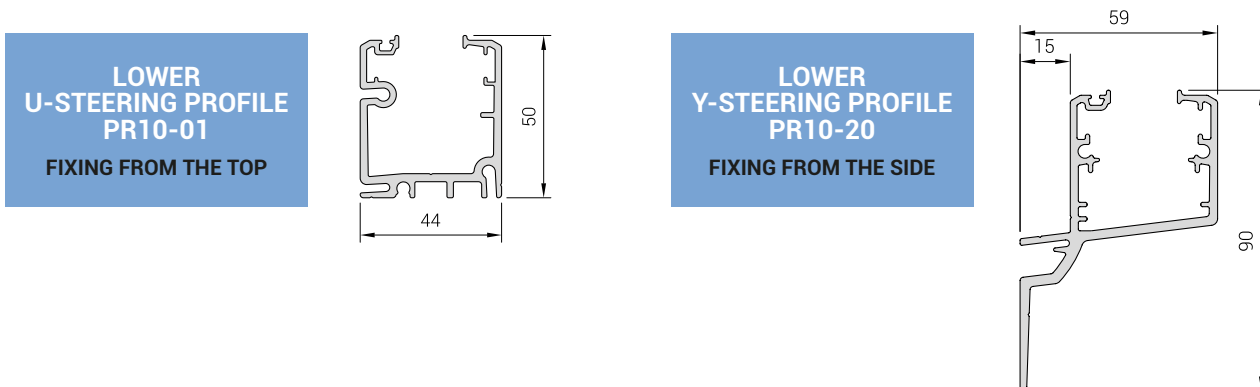

Adjustment profiles

**ADJUSTMENT
BRACKET
KS10-0013**

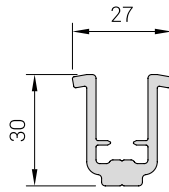

**U-ADJUSTMENT
PROFILE
PR10-03**

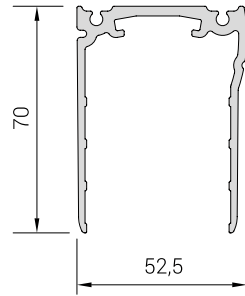

**F-ADJUSTMENT
PROFILE
PR10-21**

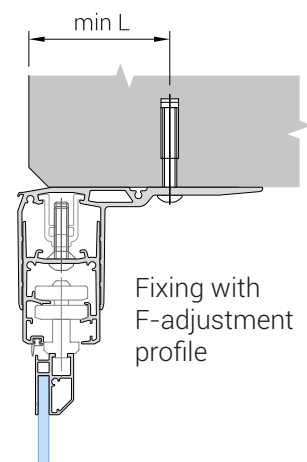
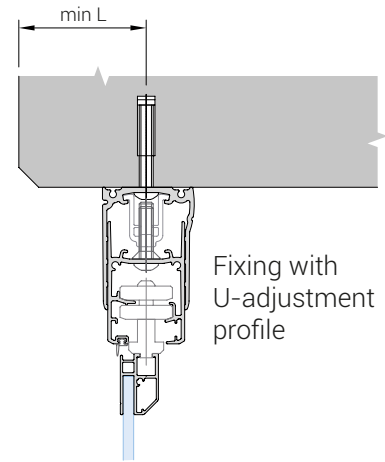
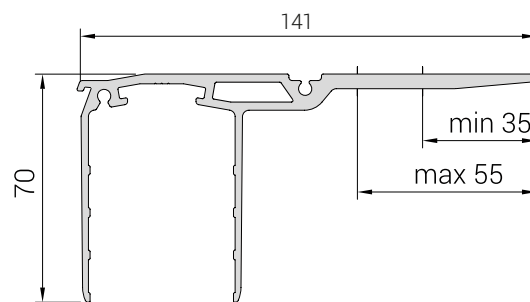

The extremes of the profile mounting holes are a minimum of 35 mm and a maximum of 55 mm from the right edge of the profile. A support surface must be provided from the centre of the mounting hole to the right end of the profile.

Glass panel profiles

**6 mm
GLASS PANEL
PROFILE
PR10-05**

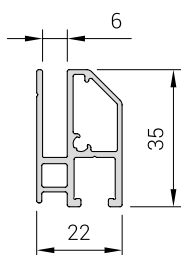

**8 mm
GLASS PANEL
PROFILE
PR10-06**

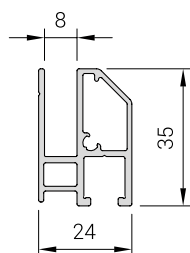

**10 mm
GLASS PANEL
PROFILE
PR10-07**

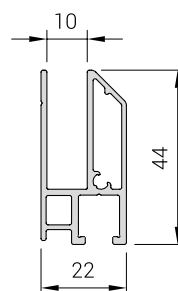

Adjustment range of the system

Standard adjustment position with adjustability between 84-105 mm using DIN 7991 M8x30 and ISO 7380-1 M8x35 bolts.

The extended adjustment position, where the adjustability is between 104-125 mm, requires a change of bolts. The bolts used are DIN 7991 M8x50 and ISO 7380-1 M8x55. The extended version can be used in cases where the mounting surface in the opening is **up to 40 mm** out of level.

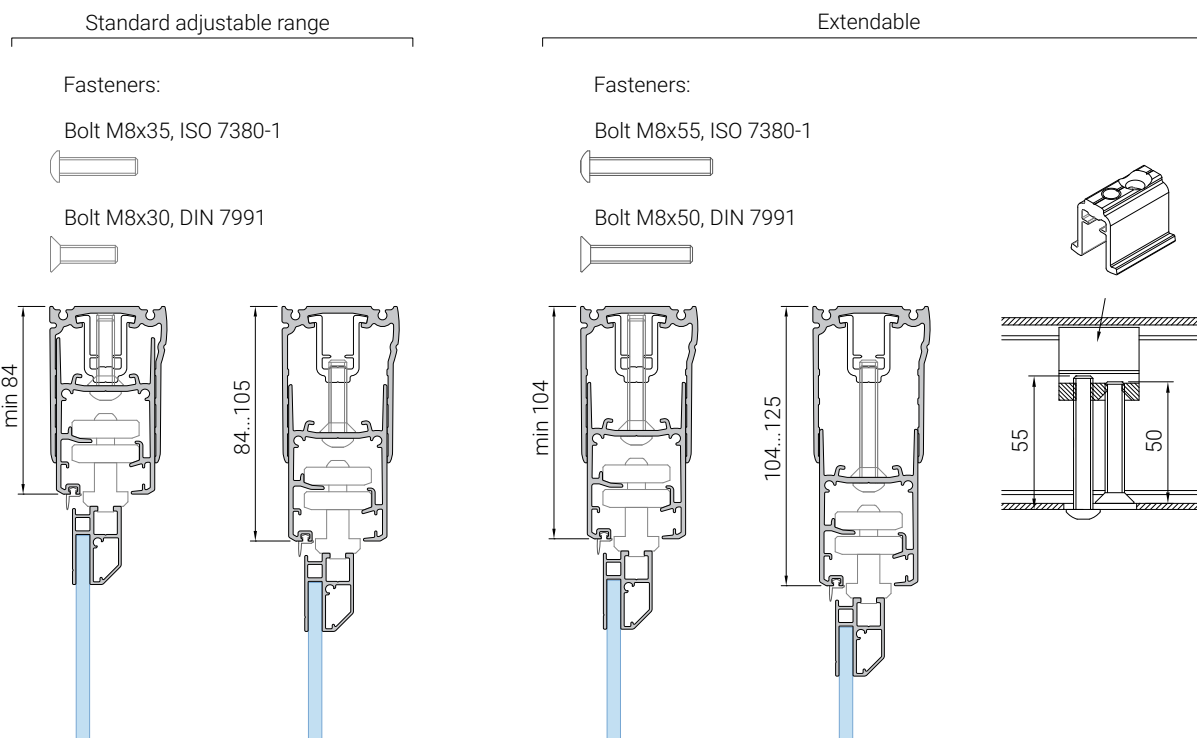

Taking measurements

Malmerk Klaasium always expects to be given final product measures (measure according to what we produce the end product in mm).

The opening has to be measured at least from three points horizontally and vertically in order to identify the shortest length and height. If the shortest points have been measured then, depending on the situation, it is advisable to deduct* a further 5-10 mm for installation reserve.

Length measure** = outer steering profile measure (including start, end and system angles; angle between the outer surfaces of the steering profiles).

Height measure = from the edge of the upper profile until the end part of the lower steering profile.

With the lower Y-steering profile, the height measure can be taken from three different points, but the bottom of the Y-steering profile has to be considered a 0-point:

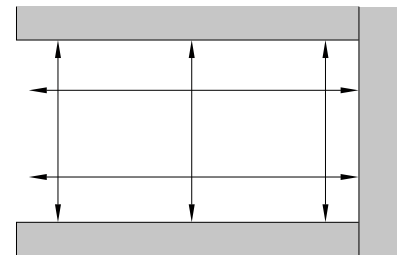
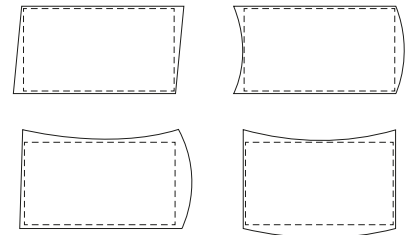

1. **Glasses parallel to the lower edge:** Height measure = Opening measure + 90 mm - reductions
2. **Installation with flashing:**
 - 2.1 Option 1: Height measure = Opening measure (e.g. from the ceiling to the railing glass profile) + 30 mm - reductions
 - 2.2 Option 2: Height measure = Opening measure (e.g. from the ceiling to the insertion point for flashing in the lower Y-steering profile) + 40 mm - reductions
3. **Installation on a certain point:** Height measure = Upper measuring point to lower measuring point - reductions

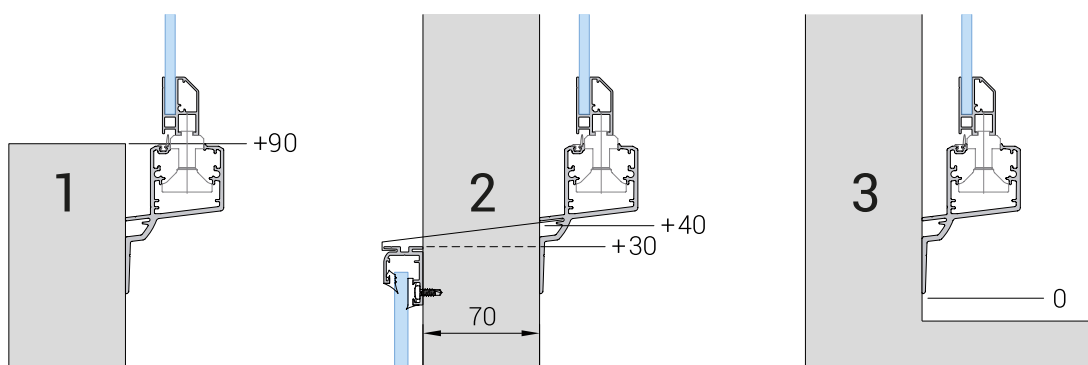

* Exact reductions are dependant on the situation, e.g. mounting surface, use of flashings, fluctuation range on the balcony, etc.

** The lower steering profiles are always produced 6 mm shorter from the given measures due to end gaps.

Standard glazing solutions with front-fixed railing

With front-fixed railing systems it is common to use an F-adjustment profile on top and a lower U- or Y-steering profile below.

Fixing to a front-fixed railing with filling up to handrail

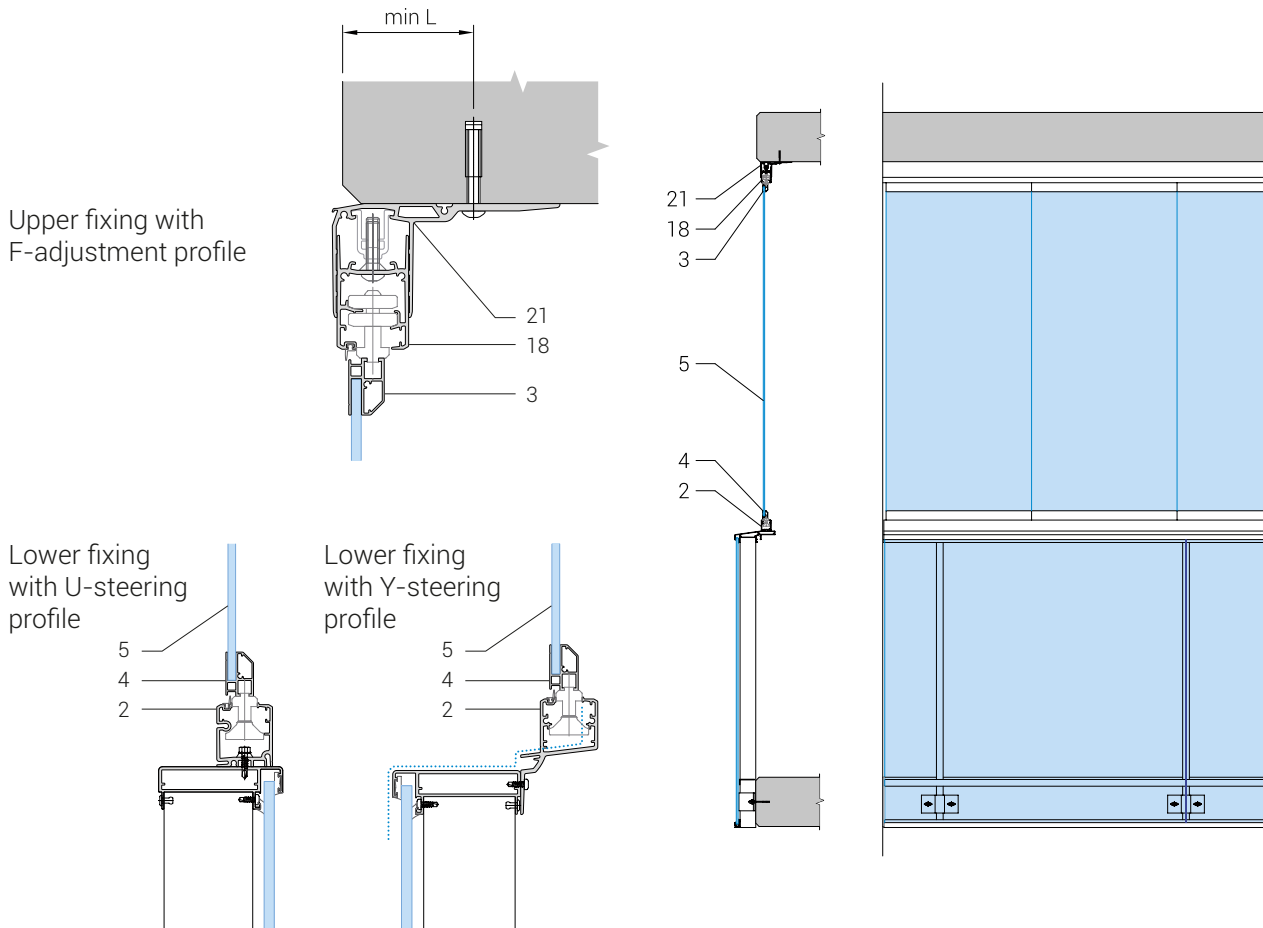

SURFACE TREATMENT

Powder-coated

COLOUR CHART

RAL

21	F-adjustment profile	141x70 mm
18	Upper H-steering profile	44x70 mm
3	Upper glass panel profile	22x35; 24x35 or 22x44
5	Glass	6, 8 or 10 mm
4	Lower glass panel profile	22x35; 24x35 or 22x44
2	Lower U-steering profile	44x50 mm

Fixing to a front-fixed railing with a gap between the filling and the handrail

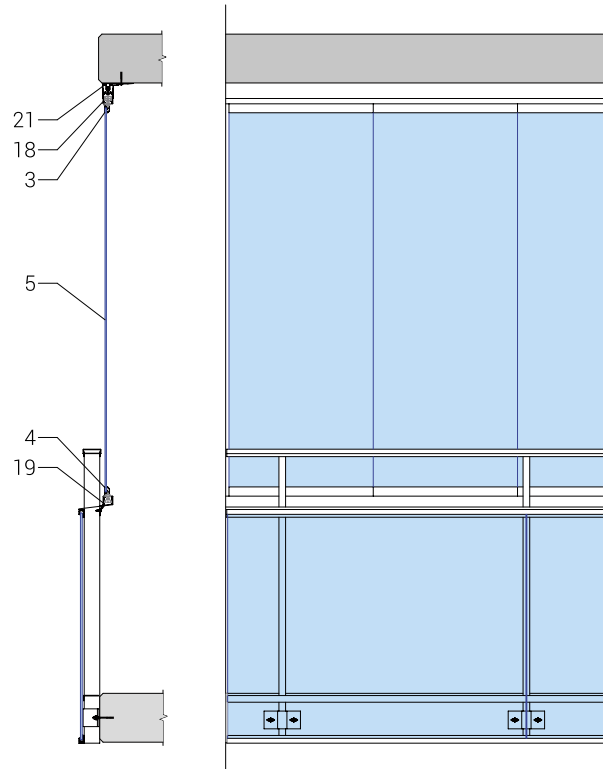
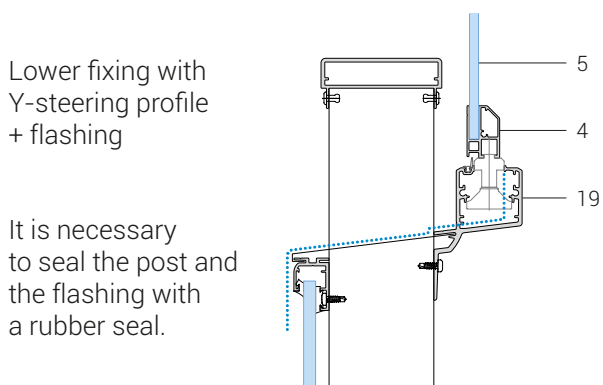
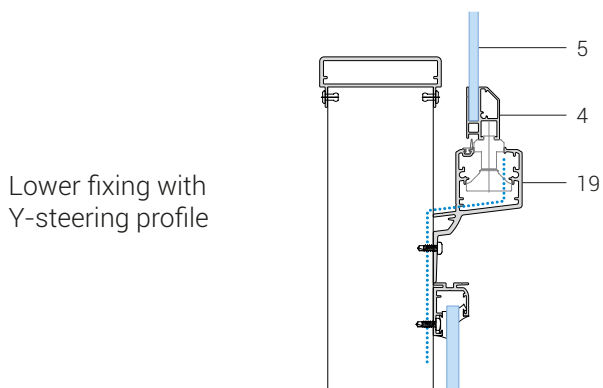
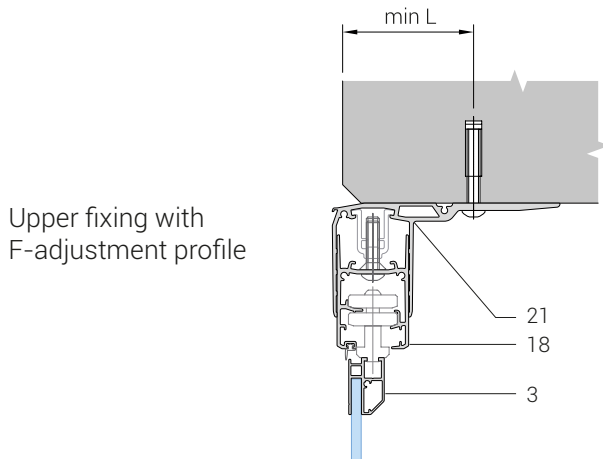

Flashing must be used to cover the gap between the pillars when the filling of the railing is outside.

SURFACE TREATMENT

Powder-coated

COLOUR CHART

RAL

21	F-adjustment profile	141x70 mm
18	Upper H-steering profile	44x70 mm
3	Upper glass panel profile	22x35; 24x35; 22x44
5	Glass	6, 8 or 10 mm
4	Lower glass panel profile	22x35; 24x35; 22x44
19	Lower Y-steering profile	59x90 mm

Standard glazing solutions with top-fixed railing

With top-fixed railing systems it is common to use a U-adjustment profile on top and a lower U- or Y-steering profile.

Fixing to a top-fixed railing with filling up to handrail

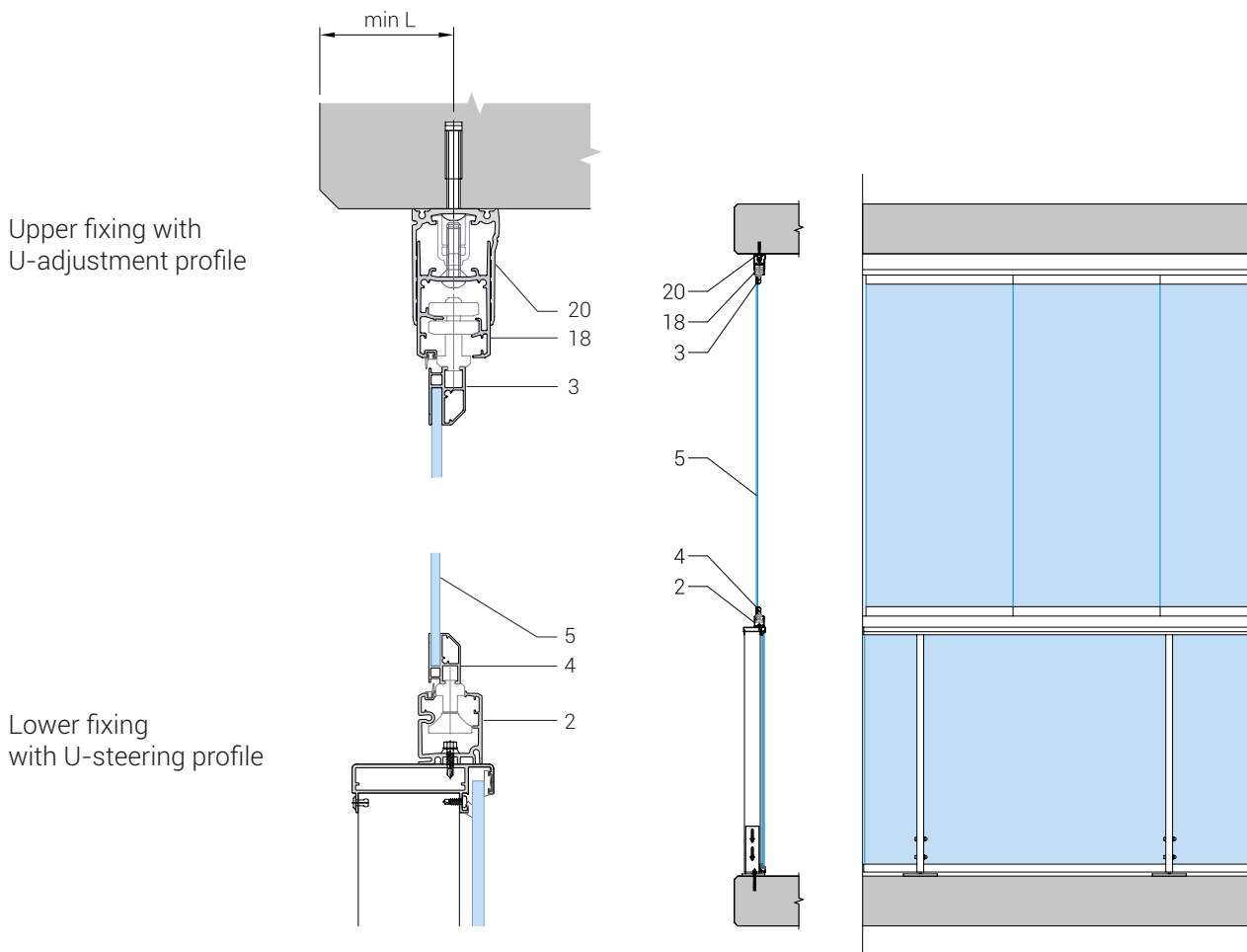

SURFACE TREATMENT
Powder-coated

COLOUR CHART
RAL

20	U-adjustment profile	52,5x70 mm
18	Upper H-steering profile	44x70 mm
3	Upper glass panel profile	22x35; 24x35 or 22x44
5	Glass	6, 8 or 10 mm
4	Lower glass panel profile	22x35; 24x35; 22x44
2	Lower U-steering profile	44x50 mm

Fixing to a top-fixed railing with a gap between the filling and the handrail

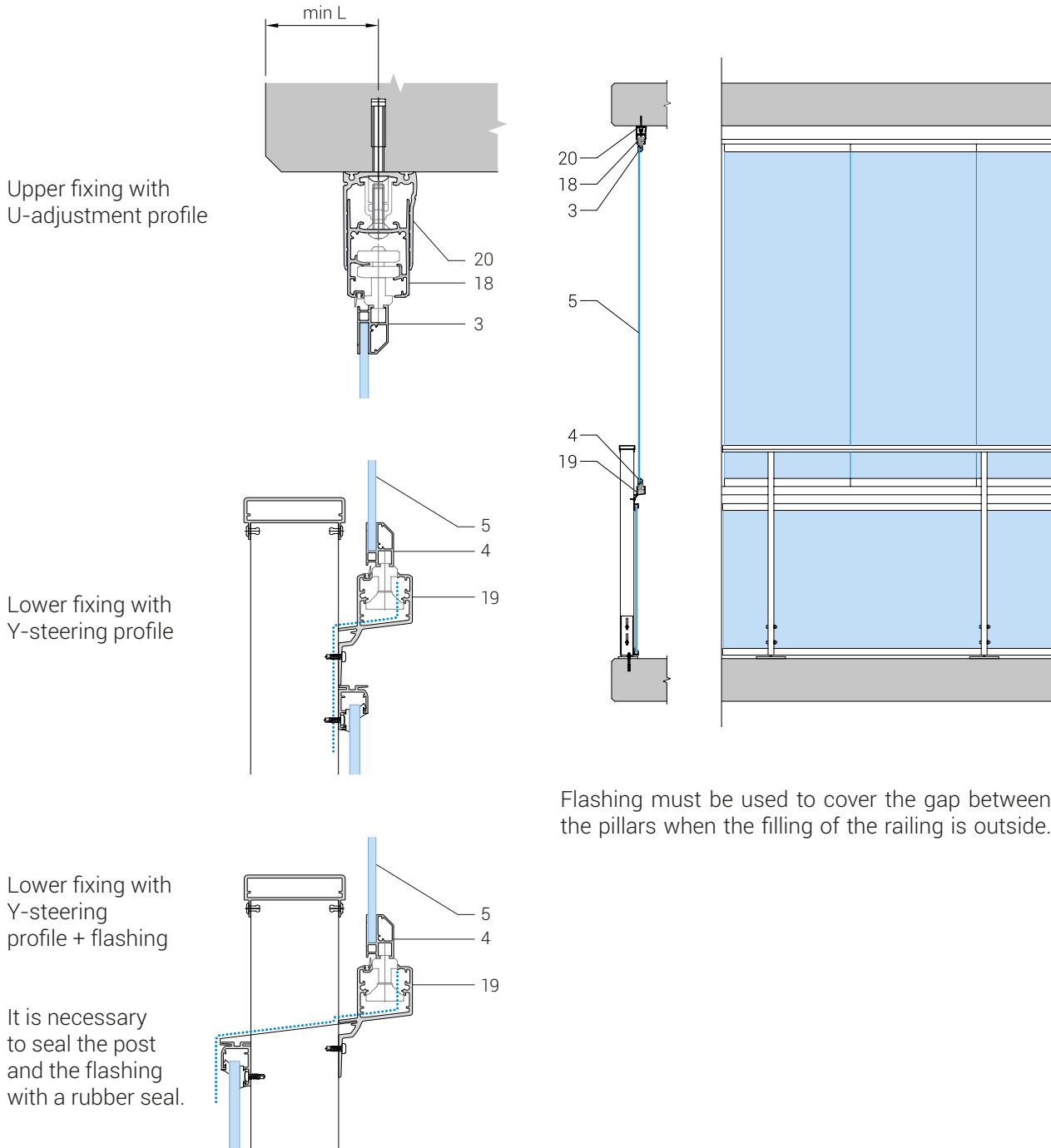

SURFACE TREATMENT

Powder-coated

COLOUR CHART

RAL

20	U-adjustment profile	52,5x70 mm
18	Upper H-steering profile	44x70 mm
3	Upper glass panel profile	22x35; 24x35; 22x44
5	Glass	6, 8 or 10 mm
4	Lower glass panel profile	22x35; 24x35; 22x44
19	Lower Y-steering profile	59x90 mm

Standard glazing solutions with rod railing

Handrail-to-ceiling solution

For handrail-to-ceiling the same glazing solutions apply as with front-fixed and top-fixed railings (see page 10-13). The difference is that with rod railing, a fixed glass needs to be added to the railing. For cleaning purposes, the glass should be openable and hence has a hinge at the bottom and a butterfly screw on top.

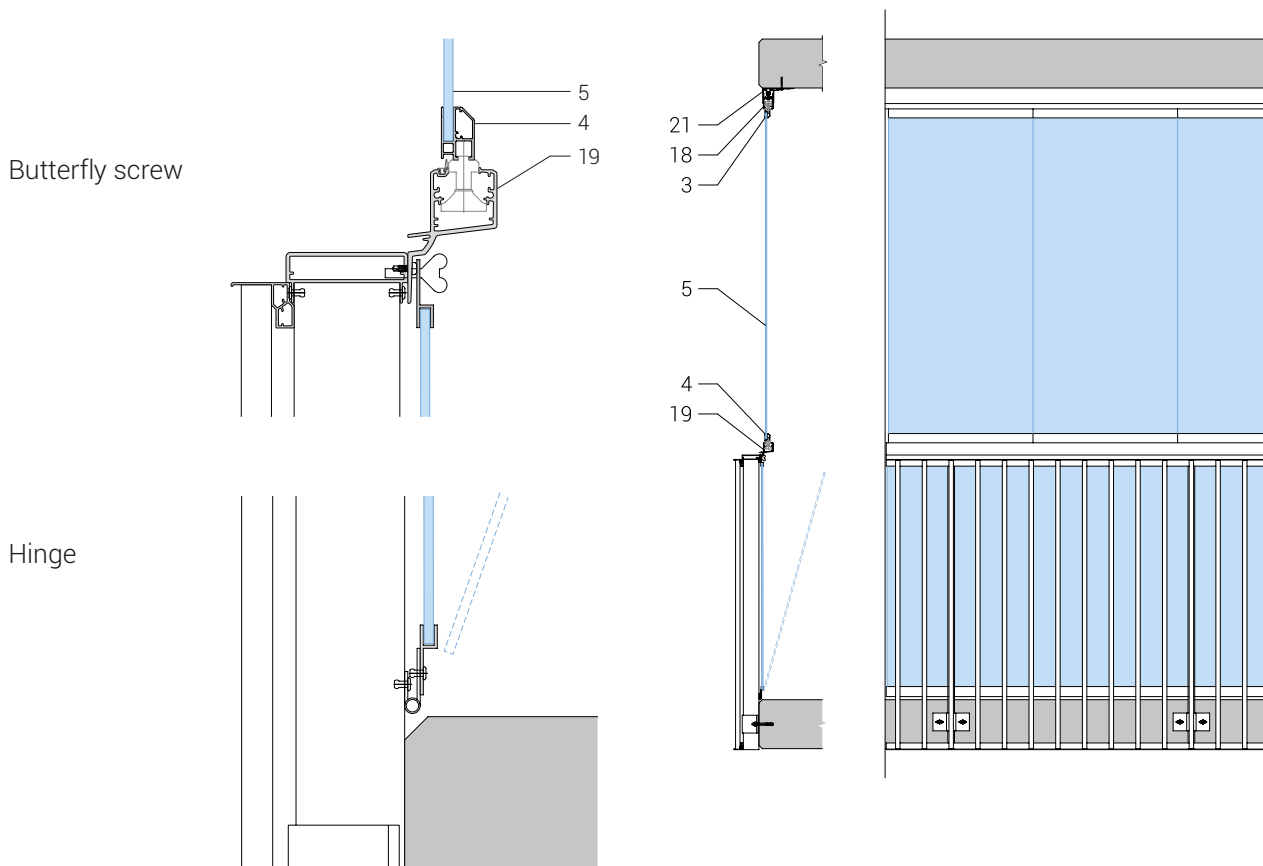

SURFACE TREATMENT
Powder-coated

COLOUR CHART
RAL

21	F-adjustment profile	141x70 mm
18	Upper H-steering profile	44x70 mm
3	Upper glass panel profile	22x35; 24x35 or 22x44
5	Glass	6, 8 or 10 mm
4	Lower glass panel profile	22x35; 24x35 or 22x44
19	Lower Y-steering profile	59x90 mm

Floor-to-ceiling solution

With the full-height glazing system, it is common to use a U-adjustment profile for the ceiling. The lower profile is either attached with a U-steering profile to the balcony floor or with a Y-steering profile to the railing pillars. **IMPORTANT:** Please note, that the max height of the railing from the Y-steering profile can be 500 mm. Otherwise it is mandatory to use >30 mm spacer due to glass deflection with wind.

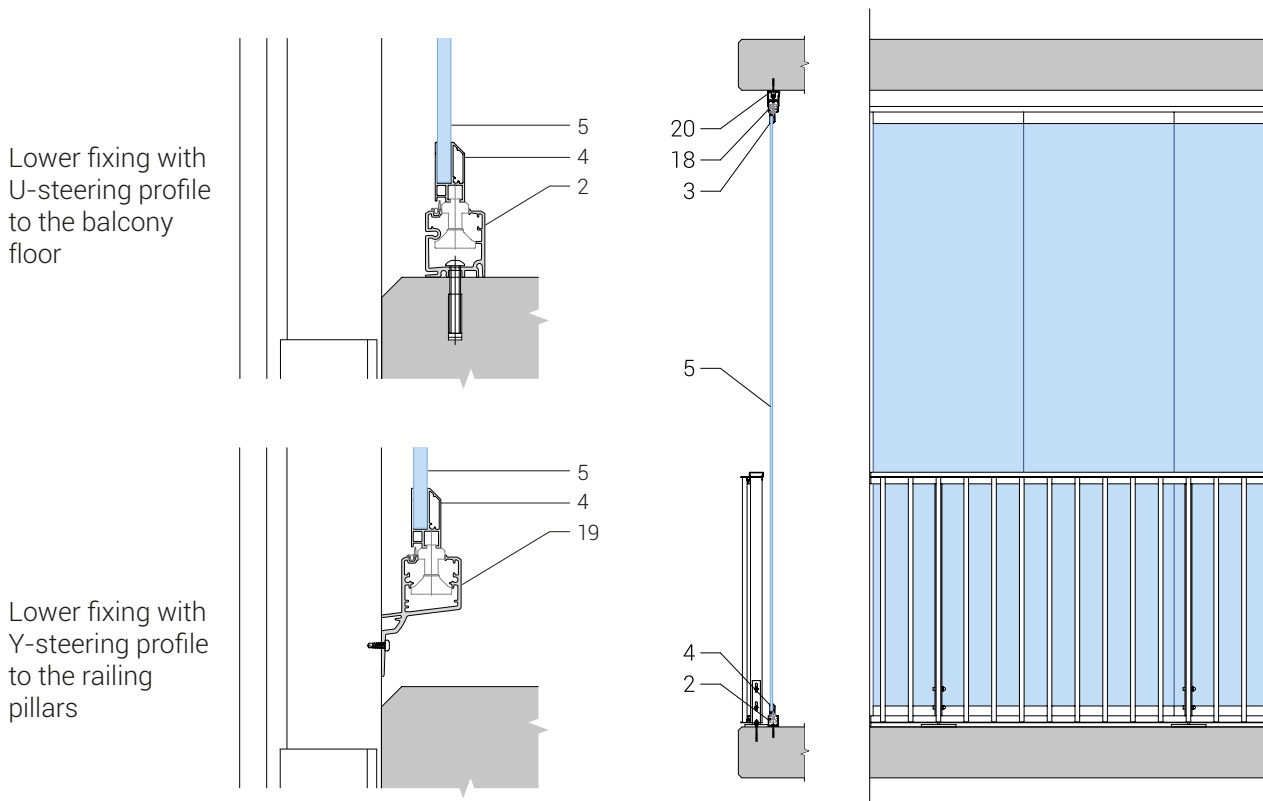

Lower fixing with
U-steering profile
to the balcony
floor

Lower fixing with
Y-steering profile
to the railing
pillars

20	U-adjustment profile	52,5x70 mm
19	Lower Y-steering profile	59x90 mm
18	Upper H-steering profile	44x70 mm
3	Upper glass panel profile	24x35 or 22x44
5	Glass	8 or 10 mm
4	Lower glass panel profile	24x35 or 22x44
2	Lower U-steering profile	44x50 mm

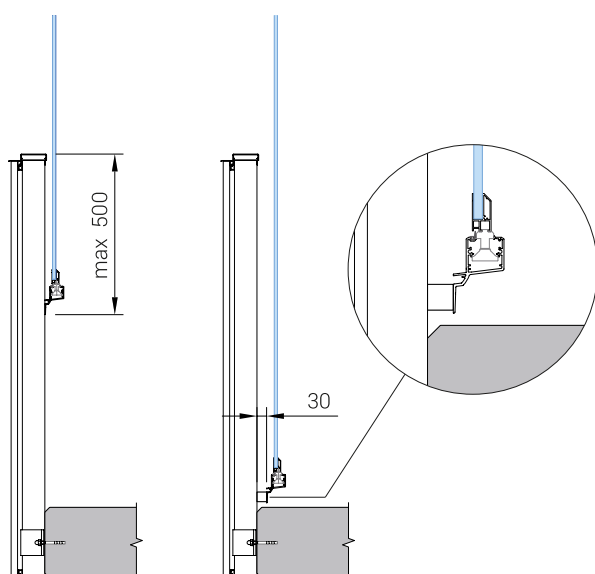

SURFACE TREATMENT
Powder-coated

COLOUR CHART
RAL

Full-height glazing system

The same system used for balconies is also used for full-height glazing system. For upper fixings, the same U- or F-adjustment profiles are used. For bottom profiles, the U-steering profile is used. It is also possible to recess the lower profile into the floor (see more information on page 17).

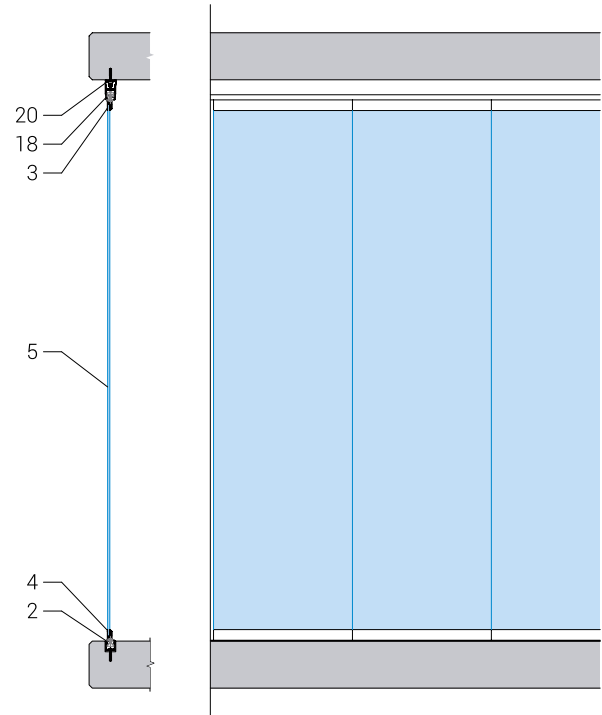
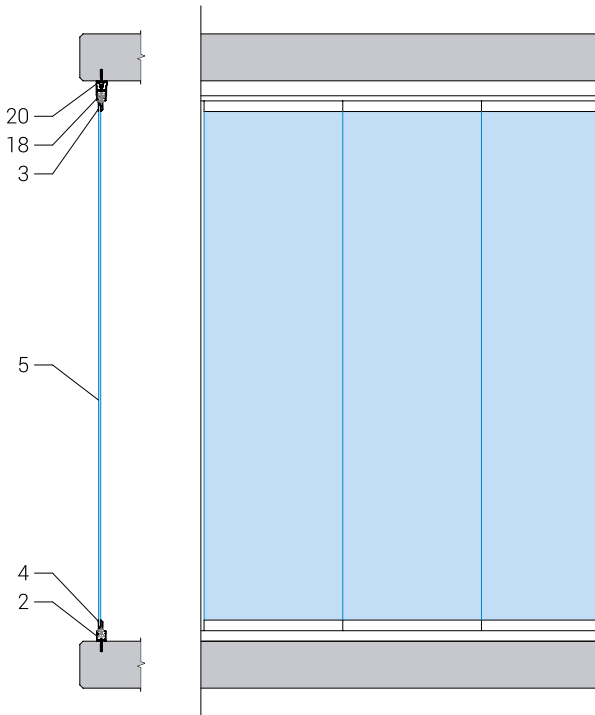

Lower fixing with U-steering profile

Lower fixing with recessed U-steering profile

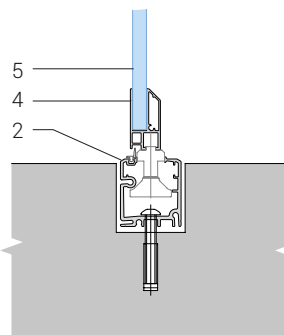
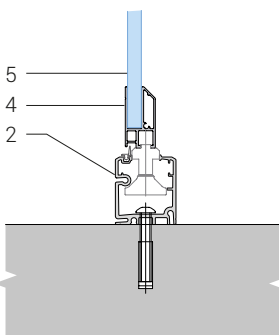

Upper fixing with U-adjustment profile

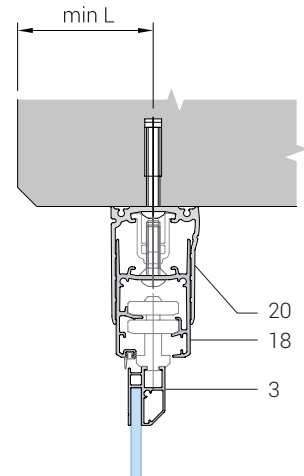

SURFACE TREATMENT
Powder-coated

COLOUR CHART
RAL

20	U-adjustment profile	52,5x70 mm
18	Upper H-steering profile	44x70 mm
3	Upper glass panel profile	24x35 or 22x44
5	Glass	8 or 10 mm
4	Lower glass panel profile	24x35 or 22x44
2	Lower U-steering profile	44x50 mm

Recessed system

The Malmerk Klaasium frameless glazing system's lower U-steering profile can be recessed. This feature is mainly used on terraces to ease access and gain a low step over, but could also be used on any other occasion when the customer wants to make the lower steering profile less visible.

When the lower steering profile is being installed, it is the responsibility of the building owner, architect, contractor or installer to ensure that the opening has been planned for a recessed system and the drainage channels are enabled to function properly. Drainage channels can be designed for the ends of the steering profile or the exterior (default) side of the system depending on the surrounding technical structures.

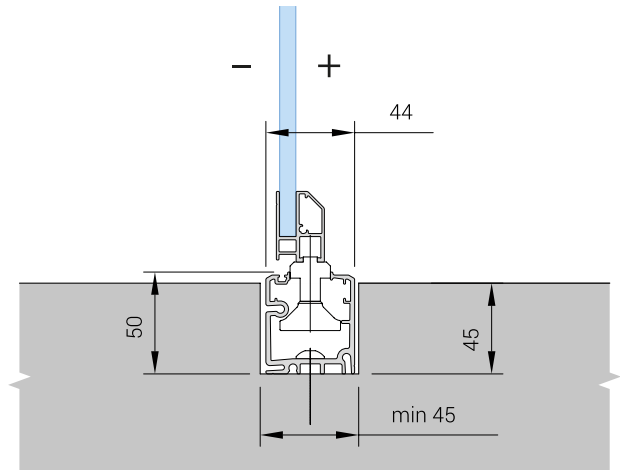

Inside

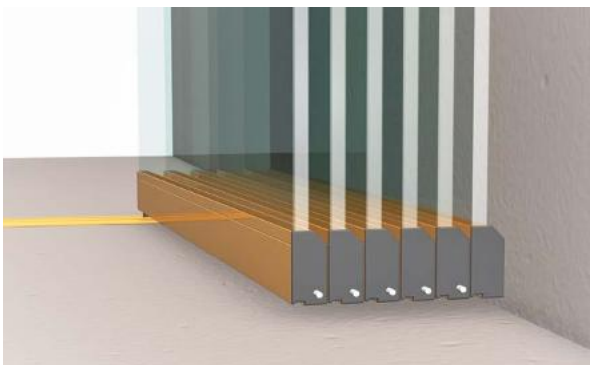

Outside

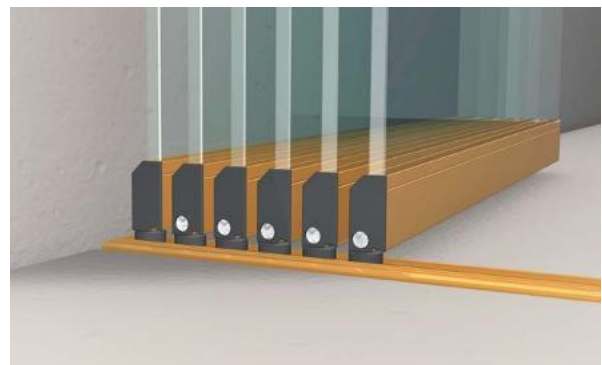

The structural integrity of the system is critical for the proper functioning of the unit. The deflection of the upper and lower steering profile under full load should be limited to a maximum of 2 mm per side.

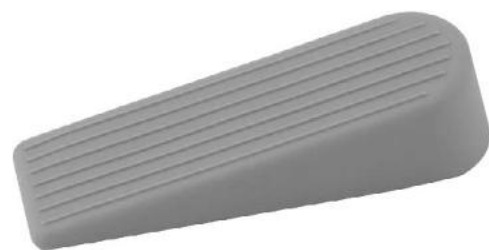

When having all the glass panels opened, restrain all units with a door stopper to prevent accidents caused by draughts (in some cases, the fixing is attached to the ceiling or some other way).

Optional

Weather strips

The gaps between the glass panels (2-4 mm) can be closed with PVC weather strips (h-gaskets) and, at the end of the system, PVC+silicone end gaps can be used to cover the gap between the wall and the glazing system.

Gasket between glass panels (h-gasket)



End-gasket



Handles

For the full-height glazing system, it is possible to add a handle with a lock (keys and/or butterfly) and/or knobs to the glasses. This needs to be specified with the order and cannot be added to the glazing system later on.

Handle lock



Knob



Extras



Our portfolio consists balcony roofs as well. Standard products for balconies up to 1300 mm depth are made of aluminium and welded to a uniform construction. Mounting brackets are easily accessible with power tools which makes installation easy. Balconies with depth more than 1300 mm, custom designed construction is produced.

Balcony roof

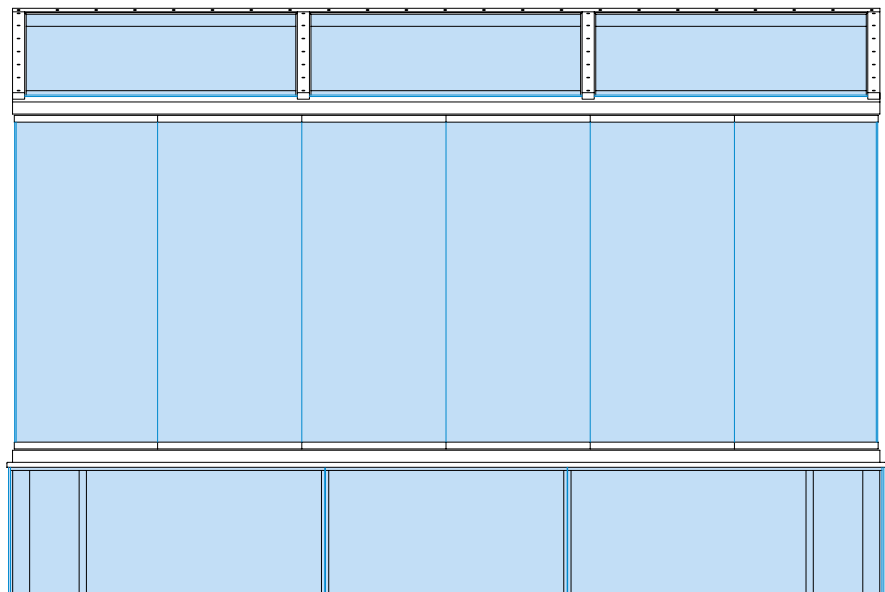
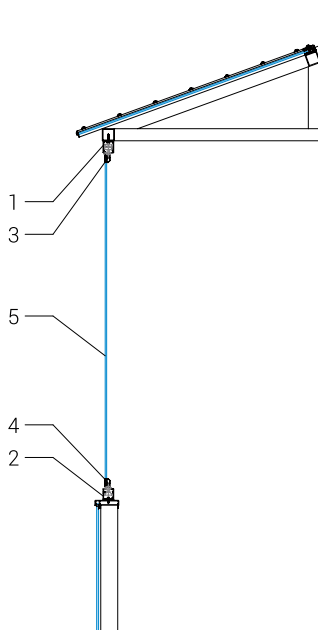

SURFACE TREATMENT
Powder-coated

COLOUR CHART
RAL

1	Upper U-steering profile	44x70 mm
3	Upper glass panel profile	22x35; 24x35; 22x44
5	Glass	6, 8 or 10 mm
4	Lower glass panel profile	22x35; 24x35; 22x44
2	Lower U-steering profile	44x50 mm

Glass height dimensioning

Malmerk Klaasium produces glazing systems with 6, 8 and 10 mm tempered glass. As a standard, the following applies:

- 6 mm glass can be up to 2000 mm
- 8 mm glass up to 2500 mm
- 10 mm glass up to 3100 mm

But in different situations (e.g high wind areas), it is best to calculate the wind loads, as in some cases the standard solution might not be sufficient.

Drawing 1:
Wind loads to a building

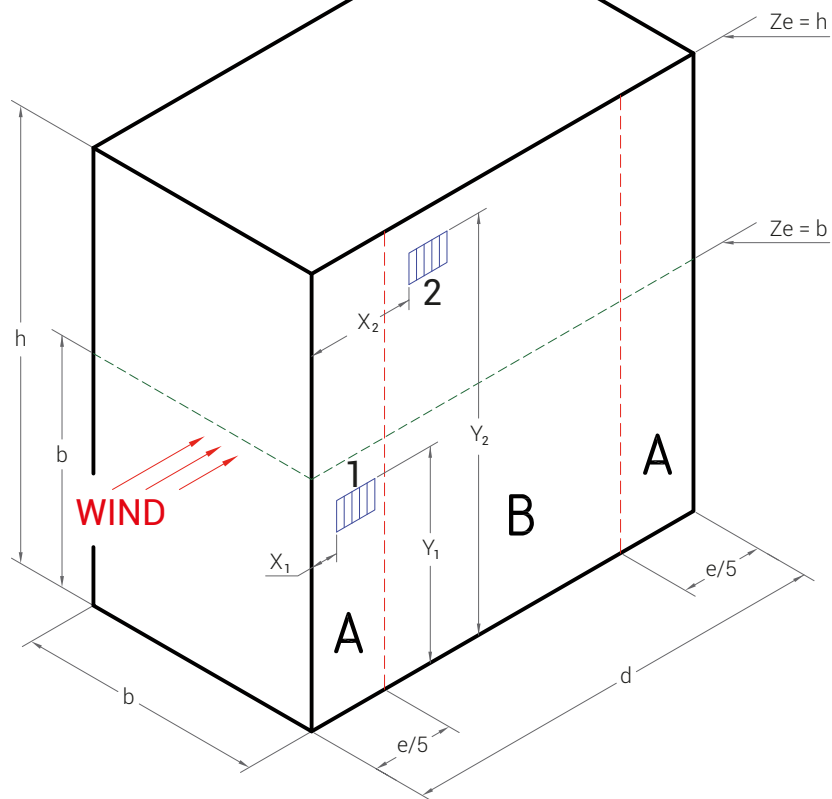

Step 1: Determining the building information (see drawing 1)

	Example:
Length of the side of the building perpendicular to the wind (marked b on drawing 1)	b=15 m
Length of the side of the building parallel to the wind (marked d on drawing 1)	d=30 m
Building height from the ground (marked h on drawing 1)	h=25 m
Basic wind velocity reference in the area (specified by the national wind maps and building regulations)	Vref=24 m/s
Determine the terrain category from table 1	Terrain category III

Step 2: Determining the information about the balconies

Balcony 1 (B1):	B1	
Height of the balcony glazing system		H=2100 mm
Height of the upper edge of the balcony from the ground (marked Y1 & Y2 on drawing 1)		Y1=13 m
Balcony distance from the side of the building (marked X1 & X2 on drawing 1)		X1=1 m
Balcony 2 (B2):	B2	
Height of the balcony glazing system		H=1500 mm
Height of the upper edge of balcony from the ground		Y2=20 m
Balcony distance from the side of the building		X2=5 m

Step 3: Determining the reference height (Ze) for the balcony

If $y \leq b$ then $Z_e = b$ Balcony 1: $y_1 \leq b$ (13 m \leq 15 m), then $Z_e = b = 15$ m	B1	$Z_e = 15$ m
If $b < y < h$ then $Z_e = h$ Balcony 2: $b < y_2 < h$ (15 m $<$ 20 m $<$ 25 m), then $Z_e = h = 25$ m	B2	$Z_e = 25$ m

Step 4: Determining the wind zones A or B

$e = b$ or $e = 2h$ (smaller is always selected) $b = 15$ m & $2h = 2 \cdot 25 = 50$ m thus $e = b = 15$ m		$e = 15$ m
When $X \leq e/5 = \text{Zone A}$ and when $X > e/5 = \text{Zone B}$		$e/5 = 3$ m
Balcony 1: ($X_1 = 1$ m) $<$ ($e/5 = 15\text{m}/5 = 3\text{m}$) thus balcony is located in Zone A	B1	$X_1 < e/5 = \text{Zone A}$
Balcony 2: ($X_2 = 5$ m) $>$ ($e/5 = 15\text{m}/5 = 3\text{m}$) thus balcony is located in Zone B	B2	$X_2 > e/5 = \text{Zone B}$

Step 5: Calculating the wind load Qw

Choose the wind pressure ($q_k = \text{kN/m}^2$) from Table 2 according to your terrain type and reference height of the balcony (Z_e).	B1 & B2	$q_k = 0.55$ & 0.65 kN/m^2
From Table 3 find the correction factor for the correct wind velocity kw	B1 & B2	1.31
From Table 4 find the wind suction load C_{pe10} for the correct wind Zone	B1 & B2	-1.2 & -0.8
Calculate the wind load $Q_w = q_k \cdot k_w \cdot C_{pe10}$		
Balcony 1: $q_k = 55 \text{ kN/m}^2$; correction factor $k_w = 1.31$ and $C_{pe} = -1.2$ thus $Q_w = 0.55 \cdot 1.31 \cdot 1.2 = 0.86 \text{ kN/m}^2$	B1	$Q_w = 0.86 \text{ kN/m}^2$
Balcony 2: $q_k = 65 \text{ kN/m}^2$; correction factor $k_w = 1.31$ and $C_{pe} = -0.8$ thus $Q_w = 0.65 \cdot 1.31 \cdot 0.8 = 0.68 \text{ kN/m}^2$	B2	$Q_w = 0.68 \text{ kN/m}^2$

Step 6: Determining the glass thickness for the balcony glazing system

From Table 5 look up the balcony glazing height and wind load (Q_w) for the correct glass thickness

Balcony 1: Glazing height=2100 mm and $Q_w = 0.86 \text{ kN/m}^2$	B1	8 mm
Balcony 2: Glazing height=1500 mm and $Q_w = 0.68 \text{ kN/m}^2$	B2	6 mm

Table 1 **Terrain category**
(according to Eurocode standards)

Terrain category	Description
0	Sea, coastal area exposed to the open sea.
I	Lake or area with negligible vegetation and without obstacles.
II	Area with low vegetation such as grass and isolated obstacles (trees, buildings) with separations of at least 20 obstacle heights.
III	Area with regular cover of vegetation or buildings or with isolated obstacles with separations of maximum 20 obstacle heights (such as villages, suburban terrain, permanent forest).
IV	Area in which at least 15% of the surface is covered with buildings and their average height exceeds 15.

Table 2 **Wind pressure $q_k = \text{kN/m}^2$**

Table 2 is valid when wind velocity reference V_{ref} is 21 m/s. If it is higher than 21 m/s, correction factor from table 3 must be used.

Balcony reference height Z_e (m)	Wind pressure q_k , kN/m^2 (wind velocity reference $V_{ref} = 21 \text{ m/s}$)				
	Terrain category				
	0	I	II	III	IV
2	0.78	0.52	0.39	0.35	0.32
5	0.96	0.65	0.53	0.35	0.32
8	1.05	0.73	0.61	0.43	0.32
10	1.09	0.76	0.65	0.47	0.32
15	1.18	0.83	0.72	0.55	0.4
20	1.24	0.88	0.77	0.6	0.45
25	1.29	0.92	0.82	0.65	0.5
30	1.33	0.95	0.85	0.68	0.54
35	1.37	0.98	0.88	0.72	0.57
40	1.4	1.01	0.91	0.74	0.6

Table 3 **Wind velocity correction factor**

Wind velocity m/s	21	22	23	24	25	26	27	28	29	30	31	32
Correction factor k_w	1.00	1.10	1.20	1.31	1.42	1.53	1.65	1.78	1.91	2.04	2.18	2.32

Table 4 **Wind zones**

Zone	A	B
Wind suction load Cpe10	-1.2	-0.8

Table 5 **Glass height dimensioning**

Glazing system height, mm	≤ 1500 mm			≤ 1600			≤ 1700			≤ 1800			≤ 1900		
Wind load, Qw, kN/m ²	≤ 1.3	≤ 2.2	≤ 3.3	≤ 1.1	≤ 2.0	≤ 3.1	≤ 0.9	≤ 1.8	≤ 2.8	≤ 0.7	≤ 1.5	≤ 2.4	≤ 0.6	≤ 1.3	≤ 2.1
Thickness of glass, mm	6	8	10	6	8	10	6	8	10	6	8	10	6	8	10

Glazing system height, mm	≤ 2000			≤ 2100			≤ 2200			≤ 2300			≤ 2400		
Wind load, Qw, kN/m ²	≤ 0.4	≤ 1,1	≤ 2.0	-	≤ 1.0	≤ 1.8	-	≤ 0.9	≤ 1,5	-	≤ 0.8	≤ 1,4	-	≤ 0.6	≤ 1.2
Thickness of glass, mm	6	8	10	-	8	10	-	8	10	-	8	10	-	8	10

Glazing system height, mm	≤ 2500			≤ 2600			≤ 2700			≤ 2800			≤ 2900			≤ 3000		
Wind load, Qw, kN/m ²	-	≤ 0.5	≤ 1.1	-	-	≤ 0.9	-	-	≤ 0.8	-	-	≤ 0.7	-	-	≤ 0.6	-	-	≤ 0.5
Thickness of glass, mm	-	8	10	-	-	10	-	-	10	-	-	10	-	-	10	-	-	10

System components

Rollers

KS10-0001
Upper locking roller



KS10-0002
Upper opening roller



KS10-0003
Lower locking roller



KS10-0004
Lower hinge roller
for first
glass



KS10-0005
Lower opening roller



KS10-0006
Lower opening latch



Recessed units

KS10-0009
Lower hinge pin
of the first glass



KS10-0010
Lower locking roller



KS10-0015
Lower locking pin
without end caps



KS10-0016
Lower locking pin
with end caps



SU10-0007
Securing block for
the last glass

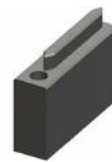

Ventilation units

KS10-0007
Ventilation
positioner



SK10-0038
Ventilation
position holder



Hole covers

SK10-0041
Upper opening-hole
cover



SK10-0040
Lower opening-hole
cover



End caps

SK10-0013
End cap 90° right side

6 mm



SK10-0014
End cap 90° left side



SK10-0011
End cap 45° right side



SK10-0012
End cap 45° left side



SK10-0017
End cap 90° right side

8 mm



SK10-0018
End cap 90° left side



SK10-0015
End cap 45° right side



SK10-0016
End cap 45° left side



SK10-0021
End cap 90° right side

10 mm



SK10-0022
End cap 90° left side



SK10-0019
End cap 45° right side



SK10-0020
End cap 45° left side



Accessories

SK10-0030
Glass panel fixing/
stopping detail



KS10-0008
Opened glass panels
securing band



SK10-0039
Roller support



SK10-0042
Locker comb







MALMERK KLAASIUM

Malmerk Klaasium OÜ

klaasium@malmerk.ee

+372 6599 240

malmerkklaasium.ee

facebook.com/malmerkklaasium

linkedin.com/company/malmerk-klaasium

Valdeku 132, 11216 Tallinn, Estonia



European Union
European Regional
Development Fund



Investing
in your future



EAS
Enterprise Estonia

