

Classic Square Series - IPL

The contemporary square shape of the IPL luminaire makes it an attractive choice for a variety of locations including commercial pathways, bike trails, public spaces, and more. With FLT's exclusive Adaptive Intelligence, the IPL provides dependable illumination throughout the night, regardless of weather conditions, or geographic location. Robust construction and unmatched performance make it an excellent choice for a high-quality illumination and minimal visual clutter. With no need to trench or pull electrical wiring, IPL is an elegant, extraordinarily cost-effective solution.

Features and Benefits

- No wiring, trenching, or electrical service required
- Integrated design eliminates visually distracting external solar panels
- Cost-effective design ships fully assembled and installs in minutes
- No ongoing maintenance
- Provides programmed illumination all night, every night
- Wireless control & communication with your light

Key Applications

- Area, Pathway, Mailbox, Parking Lot



Technical Specifications

Solar Module	<ul style="list-style-type: none"> • Industry's most efficient solar panel technology • Integrated into the top of luminaire • Active cell technology optimizes power generation even when partially blocked 	FLT's Exclusive Controller with Adaptive Intelligence	<ul style="list-style-type: none"> • Ensures all-night every-night performance by intelligently managing lighting based on environmental conditions and lighting requirements • Smart dusk/dawn detection synchronizes lights across installation using astronomical calculations • Automatically detects its timezone and sets its time for time-of-night profiles • High-efficiency, Maximum Power Point Tracking (MPPT) battery charger • High-efficiency integrated LED driver • On-board multi-year data logging
Battery	<ul style="list-style-type: none"> • High performance Lithium Iron Phosphate (LiFePO4) • Exceptional 10+ year life • High and low temperature tolerance • Integrated within luminaire housing 	Construction & Materials	<ul style="list-style-type: none"> • Rugged cast aluminum • Stainless steel fasteners • Architectural grade powder coat rated to super-durable AAMA 2604 specifications • Standard and custom colours available
LED Light Engine	<ul style="list-style-type: none"> • Integrated optics maximize application efficiency and light distribution • CCT Options: 4000K, 3000K, 2700K • Wildlife friendly, narrow-band Amber LEDs (595nm) • Type 2, 3, 4, and 5 full cut-off high efficiency optics • Optional backlight shield • Optional blue light blocker 	Wireless Control	<ul style="list-style-type: none"> • Easy-to-use interface via iOS smartphone app • Configure and control lighting profiles • Adjust dusk and dawn thresholds • Adjust motion sensor settings
Optical Performance	<ul style="list-style-type: none"> • 100,000-hour LED L70 lifetime • Typical output of 1360 lumens with default profile • Darksky approved for 3000K, 2700K, and Amber • B0- U0 - G0 BUG Rating (T4) 	Reliability & Warranty	<ul style="list-style-type: none"> • Tested for high & low heat and humidity • 5-year warranty • 10+ year battery life • Designed and manufactured in North America
Lighting Profiles	<ul style="list-style-type: none"> • 11 duration-based profiles • Easily configurable, time-of-night profiles • All profiles pre-programmed or field adjustable • Motion-sensing capabilities optimize performance based on usage 		

Order Matrix

Series	Mounting	Finish	Distribution	LED	Lighting Profiles	Options
IPL	PTM - Post Top Mount	BK - Black	T2 - Type 2	DarkSky Approved Options:	00 - On at dusk > Off at dawn	SEC - Security Fasteners
		BZ - Bronze	T3 - Type 3	WW - 3000K	01 - On at dusk > Off after 6 hours	MSO - Motion Sensor Off
		SV - Silver	T4 - Type 4	XW - 2700K	02 - On at dusk > Dim to 30% after 6 hours > Off at dawn	BLS - Backlight Shield
		WH - White	T4F - Type 4F	AMB - Amber	03 - On at dusk > Off after 5 hours > On 1 hour before dawn > Off at dawn	BLB - Blue Light Blocker
		CC- Custom Color	T5 - Type 5		04 (Default) - On at dusk > Dim to 30% after 5 hours > Brighten to 100% 1 hour before dawn > Off at dawn	
					05 - On at dusk > Off after 3 hours	
				Not DarkSky Approved:	06 - On at dusk > Off after 4 hours	
				NW - 4000K	07 - On at dusk > Off after 4 hours > On 1 hour before dawn > Off at dawn	
					08 - Off (typically used with motion sensing)	
					09 (Default) - On at dusk > Dim to 30% after 3 hours > Brighten to 100% 1 hour before dawn > Off at dawn	
					10 - On 30% at dusk > Off at dawn	
					TX0000X0000 - T=Real-time based lighting profile. X=Choose O for off, L for Low (30%) or M for Medium (50%) or B for Bright. 0000=choose event time between 00:00 and 23:59. Second event optional	

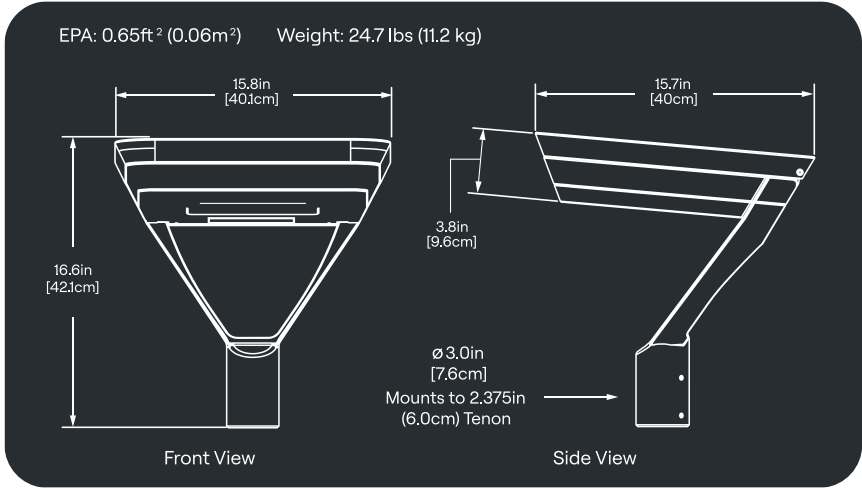
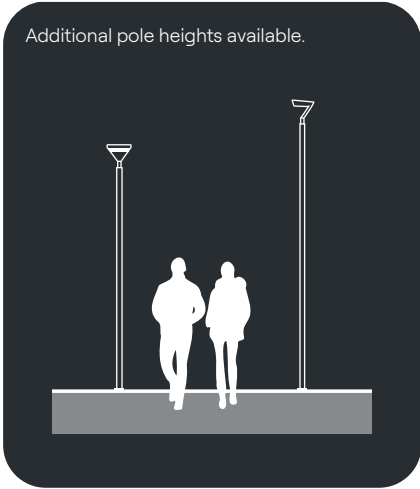

Photometrics

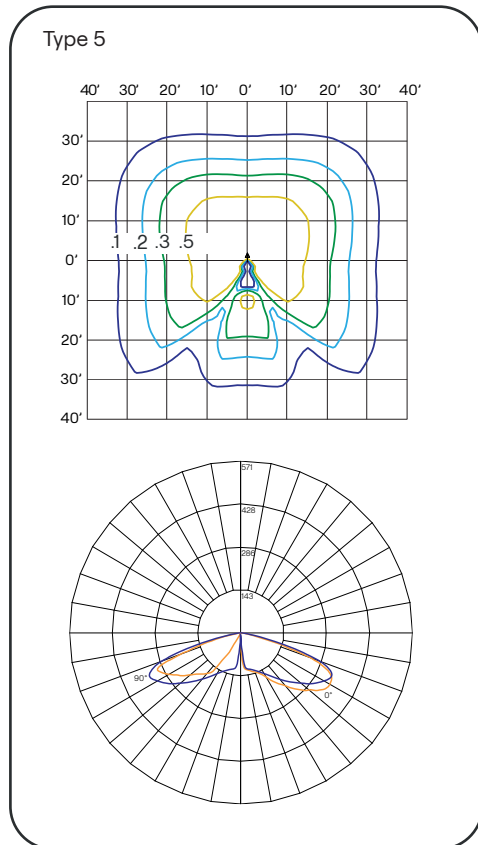
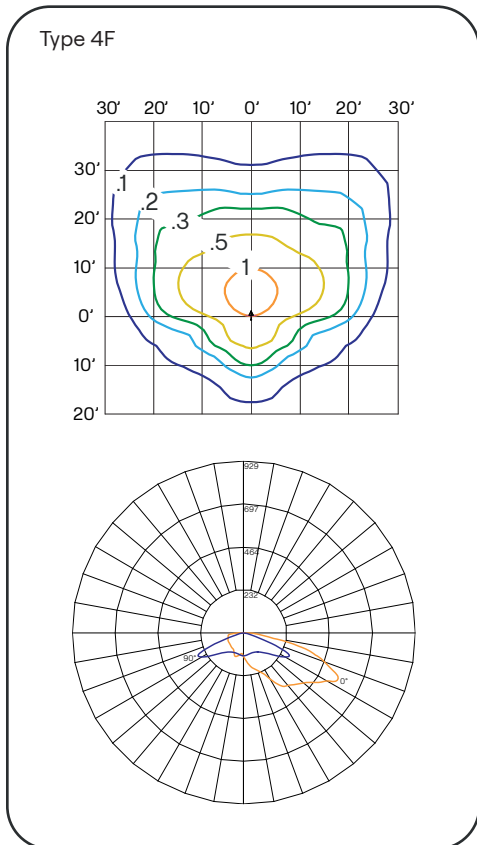
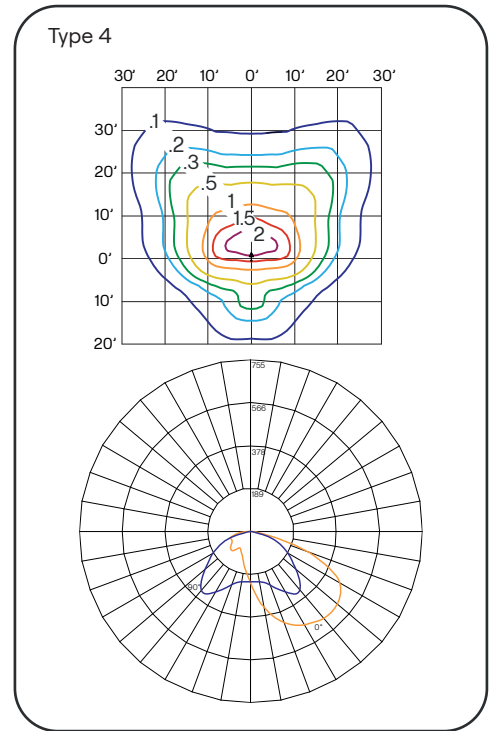
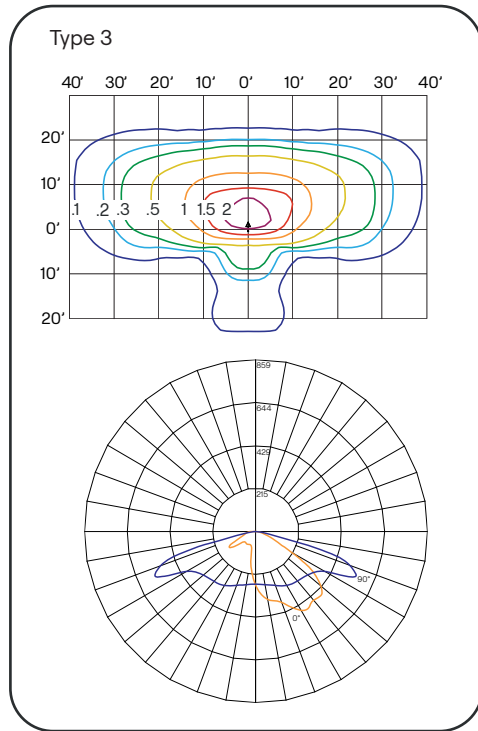
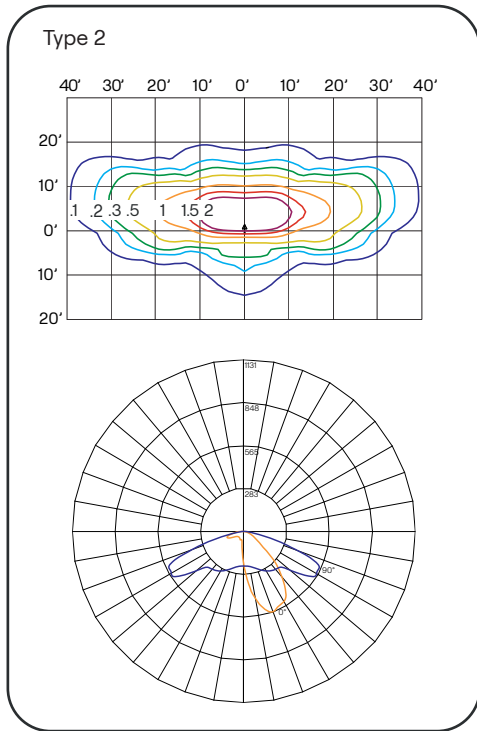

Notes:

1. All plots are for 4000K color temperature and typical lumen output
2. Illuminance plots are in foot candles and based on 12 ft mounting height
3. Polar candela plots are for the 0° and 90° Vertical Planes
4. Specifications subject to change without notice
5. IES files available at flt.com