

FMP SERIES -LARGE-

FRD MULTI-PURPOSE GRAB LARGE - FMP SERIE -

Multi-purpose grab for variable use and handling of different materials, as for example:

- Stone laying
- Sorting and handling of construction waste
- Sorting and handling of recycling material
- Excavation and loading of rough bulk material
- Loading of horticulture waste

DESIGN FEATURES

- Hydraulic rotator unit with heavy duty axial and radial bearings with rotating annulus rotator
- Flat compact design. Hydraulic cylinders and ganging guidance cpl. protected inside the frame
- Cylinders with limit damping
- Load holding valve at the cylinders prevent the unintentional opening of the grab
- Integrated mechanical opening and closing stoppers
- Wear resistant bottom teeth and side plates of high strength fine-grain steel (400 HB)
- With ESCO-plug-in exchangeable teeth
- Grab design for free oscillating use available

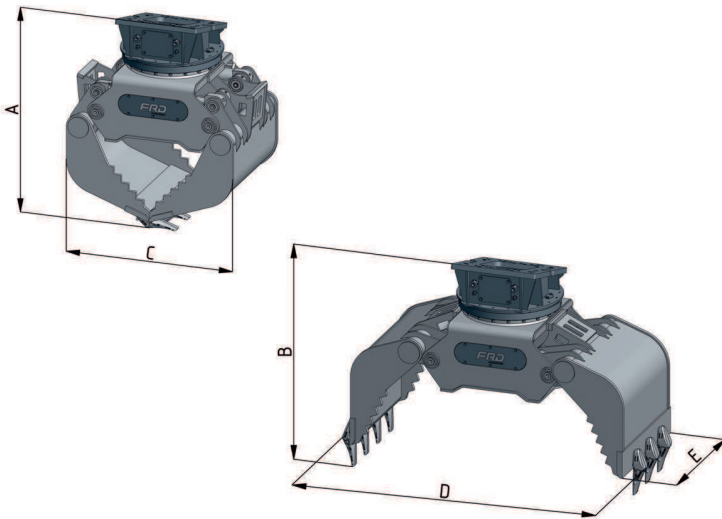

		FMP35-PL	FMP40-PL	FMP50-PL	FMP60-PL
Operating weight ¹⁾	kg	970	1665	1770	2200
Capacity	l	270	610	670	1025
Sustainability max.	t	4	6	6	8
Sust. - Rotary Engine max.	t	15	20	20	30
Dimension A	mm	1425	1630	1630	1940
Dimension B	mm	1450	1640	1640	1870
Dimension C	mm	1145	1330	1330	1500
Dimension D	mm	1935	2270	2270	2690
Width E	mm	660	940	1000	1030
Number of teeth	Stck.	5	7	7	7
Closing max.	kN	56	82	128	121
Operating pressure max.	Mpa	30	35	35	35
Oil flow max.	l/min	60	62	90	112
Operating pressure max.	Mpa	14	14	14	14
Oil flow rotator max.	l/min	30	30	30	30
Base machine weight	t	15 - 20	16 - 22	23 - 30	29 - 40

Specifications subject to change without notice. ¹⁾ Operating Weight basic unit without turning unit and mounting plate.

WHERE EXPERIENCE COUNTS