

Unlocking sustainable packaging decisions that embed circularity.

How Danone moved from seven disparate LCAs to a single comparable emissions model — across glass, aluminium and plastic water bottle formats.

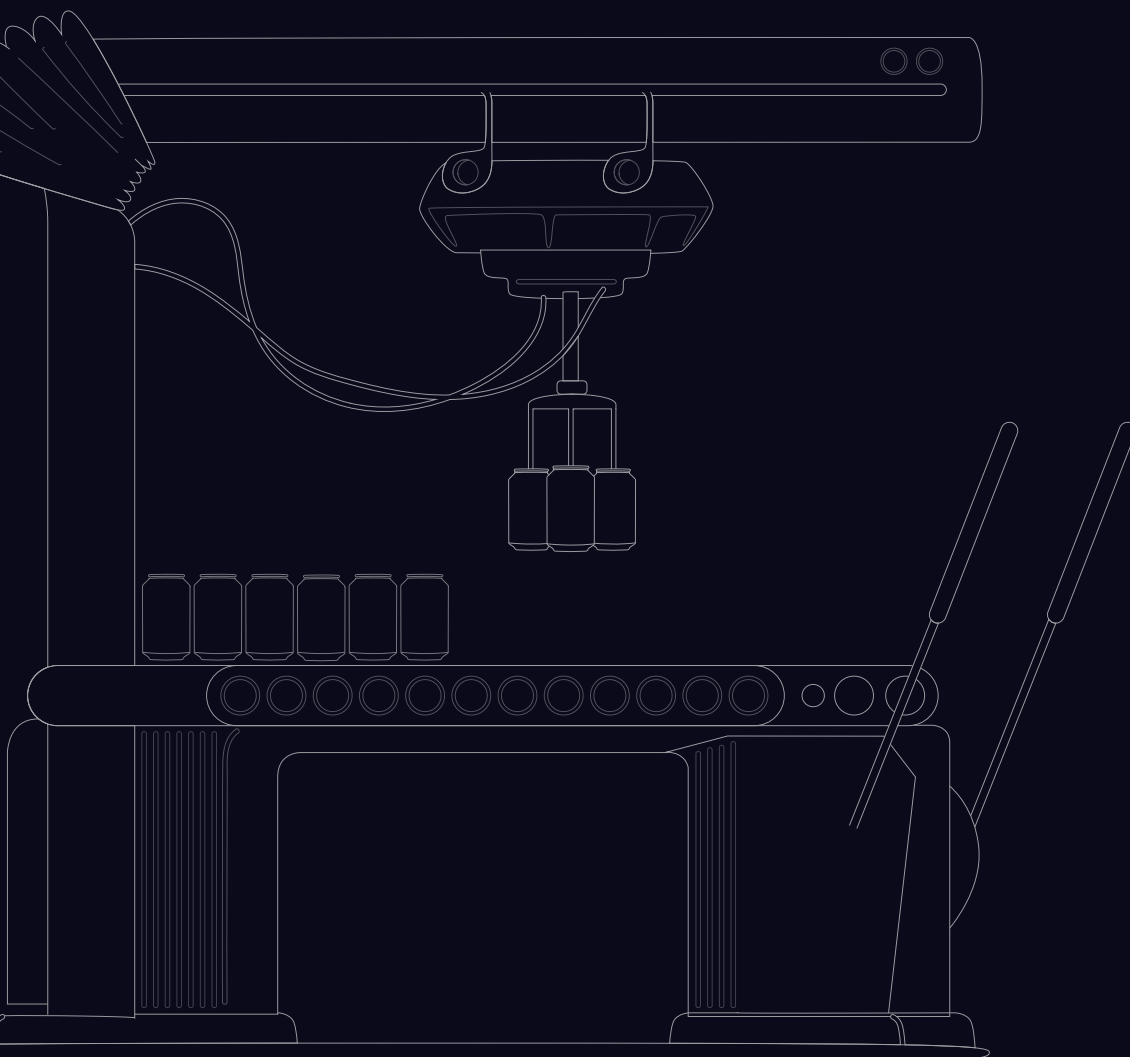

Aligning seven LCAs into one comparable truth.

Packaging decisions should not require months of parallel studies. One coherent model. Every configuration. Ready to act on.

01

1 day

Aligning 7 disparate LCAs into a single comparable source of truth.

02

3

Types of packaging analysed for water bottle products.

03

10x

Faster and cheaper than conducting an LCA, while maintaining granularity.

04

50%

Emissions reduction potential from circularity, reuse and recycled materials.

Three materials, one carbon question.

Danone needed to make informed decisions about their packaging choices for their bottled water products. This involved getting a clear overview of the product carbon footprint of their glass, aluminium or plastic water bottles. Easily comparable results were needed for environmental impact insights and clear evidence to aid internal decision-making.

The challenge was not simply technical — it was structural. Seven separate LCA studies had been conducted across different packaging types, each produced by different teams at different times using different methodologies. The data existed, but it could not be meaningfully compared.

A single packaging decision could depend on factors as varied as regional energy grids, recycled content availability, and end-of-life infrastructure. Without a unified model, those trade-offs were invisible — and the risk of acting on misaligned evidence was real.

A single packaging decision can depend on regional grids, recycled content availability, and end-of-life infrastructure. Without a unified model, those trade-offs are invisible.

— PRE-ENGAGEMENT DIAGNOSIS

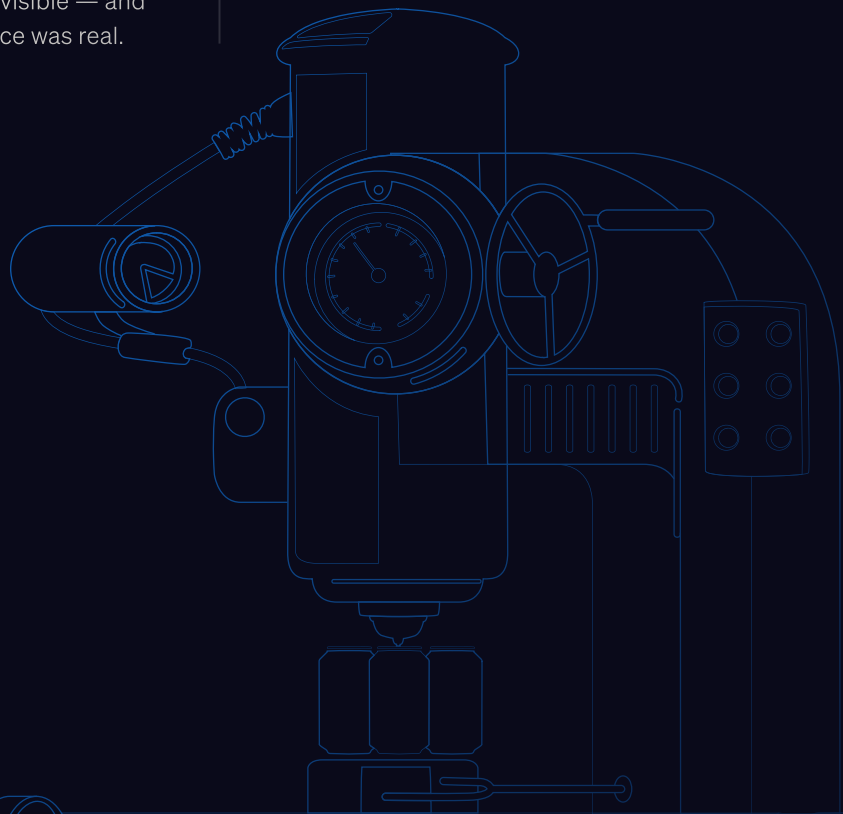

One framework, not seven separate studies.

Rather than treating each packaging type as an independent analysis, Neutreeno built a unified emissions model that could hold all three material types — glass, aluminium and plastic — within the same analytical framework. Each material's production process was modelled from the ground up, enabling direct comparison on a consistent, credible basis.

The platform ingested the data Danone already had. It identified the industrial methods used to produce each packaging type and used that knowledge to calculate the associated emissions — without requiring a full LCA for each format. Structured assumptions were made transparent, and confidence levels were quantified at every stage.

Crucially, the model was built to identify actionable decarbonisation levers specific to each packaging type: energy efficiency improvements, material composition switches, and sourcing changes. The findings were designed to travel inside the business — presentable to engineering, procurement, and leadership teams at different levels of technical depth, with the underlying model available for interrogation rather than a static report.

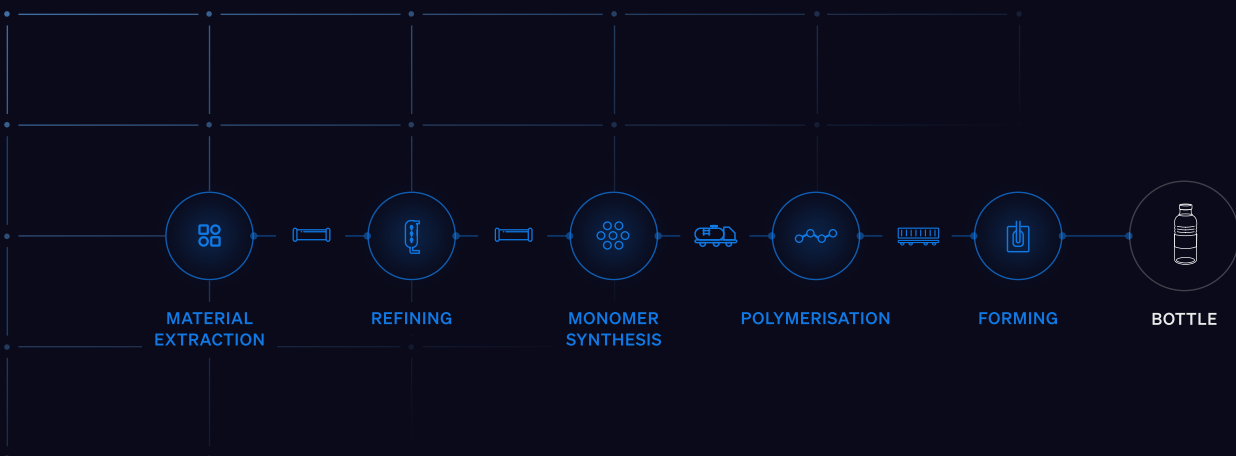

Seven studies unified. Decisions unlocked.

Neutreeno's platform calculated credible outputs aligned with GHG Protocol, ISO 14067, and PACT frameworks, providing trusted data for internal teams, external partners, and customers.

Using readily available data inputs, Neutreeno's intelligent system identified the industrial methods used to produce each packaging type and calculated the associated emissions — bypassing the lengthy process of a full Life Cycle Assessment for each format. The result was a 10× speed improvement over conventional LCA methods, while maintaining the granularity needed for credible, comparable evidence.

Actionable decarbonisation levers specific to each packaging type were surfaced: energy efficiency improvements, material composition switches such as increased recycled content, and sourcing changes aligned with regional infrastructure realities. The results fed directly into a wider environmental impact assessment conducted by CISL, providing the granular product-level data needed to understand the nuanced trade-offs between packaging options — and the potential of future improvements.

Neutreeno identified process-specific granular insights — such as recycled content levels — that fed directly into CISL's holistic environmental impact assessment.

— ENGAGEMENT FINDING



Neutreeno's bottom-up decarbonisation platform modelled our production processes to deliver highly granular facility-level results in a short timeframe, providing **credible, comparable evidence**.

Jess Ainley

SENIOR SUSTAINABILITY MANAGER · DANONE

A unified, **credible** model that informs decisions as they happen.

Within weeks of receiving Danone's initial data, Neutreeno returned credible, comparable product carbon footprints across all three packaging types — alongside specific, prioritised actions the sustainability team could act on immediately.

01 /

Comparability

Direct, uniform comparisons between glass, aluminium and plastic water bottle packaging — using a single consistent analytical framework aligned to GHG Protocol, ISO 14067 and PACT.

02 /

Granularity

Process-specific insights including recycled content levels and facility-level data, feeding into CISL's wider holistic environmental impact assessment of packaging solutions.

03 /

Decision-readiness

Outputs designed to travel inside Danone's business — presentable to engineering, procurement, and leadership at different levels of technical depth, with the underlying model available for ongoing interrogation rather than a static, one-time report.

neutreeno

Stop waiting for seven separate studies. Start acting on the data you already have.

[SCHEDULE A DEMO](#)

[NEUTREENO.COM / CASE-STUDIES](#)

NEUTREENO

The world's first company to use emissions intelligence to improve business performance while decarbonising.

ADDRESS

Cambridge Institute for Sustainability Leadership, 1 Regent Street, Cambridge, CB1 2XL, United Kingdom

CONTACT

contact@neutreeno.com
neutreeno.com
linkedin.com/company/neutreeno