

CLASS II-A
MAX. RPM
1013

CLARAGE TYPE NH FANS

NON-OVERLOADING MEDIUM SPEED HIGH EFFICIENCY

SIZE 98
SINGLE WIDTH
SINGLE INLET

Outlet Size 39 3/8" x 51 3/4" Outside

Wheel Diameter 49 in.

Inlet Size 54" Dia. Outside

Outlet Area 13.85 Sq. Ft. Inside

Tip Speed = RPM x 12.83

Max. BHP = 81.31 (RPM/1000)³

Volume of Air CFM	Outlet Velocity ft per M	1/4" SP		3/8" SP		1/2" SP		5/8" SP		3/4" SP		7/8" SP		1" SP		1 1/4" SP		1 1/2" SP		1 3/4" SP	
		RPM	BHP	RPM	BHP	RPM	BHP	RPM	BHP	RPM	BHP	RPM	BHP	RPM	BHP	RPM	BHP	RPM	BHP	RPM	BHP
11080	800	200	.65	226	.90	251	1.16	275	1.44	298	1.76	320	2.11	341	2.47	381	3.23	417	4.03	450	4.85
12465	900	213	.79	236	1.05	259	1.34	281	1.63	302	1.94	323	2.27	343	2.65	382	3.45	417	4.31	450	5.19
13850	1000	227	.96	248	1.23	269	1.55	289	1.86	309	2.19	328	2.52	347	2.88	383	3.68	418	4.57	451	5.51
15235	1100	241	1.14	261	1.44	279	1.77	298	2.11	317	2.45	335	2.81	353	3.19	387	3.96	420	4.86	452	5.83
16620	1200	256	1.36	274	1.68	291	2.02	309	2.38	327	2.76	344	3.13	360	3.53	393	4.34	424	5.19	454	6.16
18005	1300	272	1.61	288	1.95	304	2.31	321	2.69	337	3.07	353	3.48	369	3.89	399	4.75	429	5.62	458	6.55
19390	1400	288	1.88	303	2.27	318	2.63	334	3.03	348	3.43	363	3.86	378	4.29	408	5.19	436	6.11	463	7.06
20775	1500	304	2.20	318	2.60	333	3.01	347	3.41	361	3.84	375	4.28	389	4.74	417	5.66	444	6.63	470	7.63
22160	1600	321	2.56	334	2.99	348	3.42	361	3.85	374	4.28	387	4.74	400	5.21	427	6.19	453	7.20	478	8.24
23545	1700	338	2.98	350	3.41	363	3.86	375	4.32	388	4.76	400	5.25	413	5.73	437	6.74	462	7.80	486	8.88
24930	1800	355	3.43	366	3.86	378	4.35	390	4.82	402	5.30	414	5.80	426	6.30	449	7.35	472	8.45	495	9.57
26315	1900	372	3.92	383	4.38	394	4.89	405	5.40	417	5.90	428	6.41	439	6.93	461	8.01	483	9.14	505	10.30
27700	2000			400	4.94	410	5.46	421	6.01	432	6.54	442	7.06	453	7.60	474	8.71	495	9.89	516	11.09
29085	2100			417	5.58	426	6.09	437	6.66	447	7.23	457	7.78	467	8.34	488	9.49	508	10.68	527	11.92
30470	2200			434	6.27	443	6.79	453	7.37	462	7.96	472	8.55	482	9.14	502	10.30	521	11.54	539	12.83
31855	2300					460	7.53	469	8.13	478	8.75	487	9.36	497	9.99	516	11.20	534	12.45	552	13.77
33240	2400					477	8.37	486	8.96	494	9.60	503	10.26	512	10.89	530	12.16	548	13.39	565	14.82
34625	2500					494	9.27	503	9.86	511	10.50	519	11.18	527	11.86	545	13.19	562	14.54	579	15.93
36010	2600							520	10.82	528	11.47	535	12.23	543	12.88	560	14.27	577	15.65	593	17.04
38780	2800							553	13.01	561	13.64	568	14.40	576	15.10	590	16.62	607	18.14	622	19.67
41550	3000							588	15.51	594	16.20	601	16.90	609	17.59	622	19.25	637	20.91	651	22.44
44320	3200									628	18.97	634	19.81	642	20.50	655	22.16	668	23.96	681	25.62
47090	3400									663	22.02	669	22.99	675	23.82	688	25.48	701	27.28	712	29.09
49860	3600									698	25.07	704	26.45	709	27.42	721	29.09	734	30.89	745	32.82

Volume of Air CFM	Outlet Velocity ft per M	2" SP		2 1/2" SP		3" SP		3 1/2" SP		4" SP		4 1/2" SP		5" SP		5 1/2" SP		6" SP		6 1/2" SP	
		RPM	BHP	RPM	BHP	RPM	BHP	RPM	BHP	RPM	BHP	RPM	BHP	RPM	BHP	RPM	BHP	RPM	BHP	RPM	BHP
13850	1000	482	6.48	538	8.50																
15235	1100	482	6.84	538	8.96																
16620	1200	484	7.22	539	9.45																
18005	1300	486	7.60	540	9.88	590	12.35	637	14.82	681	18.01										
19390	1400	490	8.07	542	10.36	591	12.87	638	15.51	681	18.28										
20775	1500	495	8.66	545	10.87	593	13.42	639	16.20	682	18.97										
22160	1600	502	9.29	549	11.52	595	13.99	640	16.76	683	19.67	723	22.71	761	25.76	798	28.95	834	32.13	867	35.46
23545	1700	510	9.99	555	12.28	599	14.68	642	17.45	684	20.36	724	23.55	762	26.73	799	29.78	834	33.24	868	36.70
24930	1800	518	10.72	562	13.09	604	15.51	646	18.14	686	21.19	725	24.38	763	27.56	800	30.75	835	34.49	868	37.95
26315	1900	527	11.50	570	13.99	611	16.48	650	19.11	689	22.02	727	25.21	764	28.53	801	31.72	835	35.59	869	39.20
27700	2000	537	12.35	578	14.82	618	17.45	656	20.22	694	22.99	730	26.18	766	29.50	802	32.69	836	36.56	870	40.30
29085	2100	548	13.20	587	15.79	626	18.56	663	21.33	699	24.24	735	27.28	770	30.47	804	34.07	838	37.67		
30470	2200	559	14.13	597	16.90	634	19.67	670	22.58	706	25.48	740	28.53	774	31.72	807	35.18	840	38.78		
31855	2300	570	15.10	607	17.87	643	20.78	678	23.82	713	26.87	746	29.92	779	33.10	811	36.43	843	40.17		
33240	2400	583	16.20	618	19.11	653	22.02	687	25.07	720	28.25	753	31.44	785	34.63	816	38.09	847	41.55		
34625	2500	596	17.31	629	20.22	663	23.27	696	26.45	729	29.64	760	32.96	792	36.29	822	39.75	852	43.21		
36010	2600	610	18.42	641	21.47	674	24.65	706	27.84	738	31.16	769	34.49	799	37.95	829	41.41	858	45.01		
38780	2800	637	21.05	667	24.24	696	27.56	727	30.89	757	34.35	786	37.95	815	41.55	844	45.15	872	48.75		
41550	3000	666	24.10	694	27.28	722	30.75	749	34.21	778	37.95	806	41.55	833	45.29	861	49.17	887	53.05		
44320	3200	695	27.28	722	30.75	749	34.21	774	37.95	801	41.69	827	45.57	853	49.44	879	53.46	905	57.62		
47090	3400	725	30.89	751	34.49	776	38.23	801	41.97	825	45.84	850	49.86	875	54.02	899	58.17	924	62.33		
49860	3600	756	34.76	781	38.64	805	42.38	828	46.40	852	50.41	874	54.57	898	58.86	921	63.16				
52630	3800	788	39.06	811	43.21	834	47.23	856	51.25	879	55.40	901	59.69	922	64.13	944	68.56				
55400	4000	821	43.63	841	48.06	864	52.35	885	56.51	906	60.80	928	65.23	949	69.67	969	74.37				

All Capacities Based on Standard Air (Density .075#/cu.ft.—70° F.—29.92" Hg. Bar.)

NOTES: (1) Ball bearings are standard on all Type NH, Class II-A Fans. (2) Values underlined indicate the most efficient point of operation for each pressure. (3) When equipped with Vortex Control increase speed 1%.

SIZE 108^{1/2}
SINGLE WIDTH
SINGLE INLET

CLARAGE TYPE NH FANS

NON-OVERLOADING MEDIUM SPEED HIGH EFFICIENCY

CLASS II-A
MAX. RPM
915

Outlet Size 43^{3/4}" x 57^{1/8}" Outside

Wheel Diameter 54^{1/4} in.

Inlet Size 59" Dia. Outside

Outlet Area 16.92 Sq. Ft. Inside

Tip Speed = RPM x 14.20

Max. BHP = 135.0 $\left(\frac{\text{RPM}}{1000}\right)^3$

Volume of Air CFM	Outlet Velocity ft per M	1/4" SP		3/8" SP		1/2" SP		5/8" SP		3/4" SP		7/8" SP		1" SP		1 1/4" SP		1 1/2" SP		1 3/4" SP	
		RPM	BHP	RPM	BHP	RPM	BHP	RPM	BHP	RPM	BHP	RPM	BHP	RPM	BHP	RPM	BHP	RPM	BHP	RPM	BHP
13536	800	181	.80	204	1.10	227	1.42	248	1.76	269	2.15	289	2.57	308	3.01	344	3.94	377	4.92	407	5.92
15228	900	192	.96	213	1.29	<u>234</u>	<u>1.64</u>	254	2.00	273	2.37	292	2.77	310	3.23	345	4.21	377	5.26	407	6.35
16920	1000	205	1.17	224	1.51	242	1.90	261	2.27	279	2.67	296	3.08	313	3.52	346	4.50	378	5.58	407	6.73
18612	1100	218	1.39	235	1.76	252	2.17	270	2.57	286	2.99	303	3.43	319	3.89	350	4.84	379	5.94	408	7.12
20304	1200	231	1.66	247	2.05	263	2.47	279	2.91	295	3.37	310	3.82	<u>325</u>	<u>4.31</u>	355	5.30	383	6.35	410	7.53
21996	1300	245	1.96	260	2.39	275	2.83	290	3.28	305	3.76	319	4.25	333	4.75	361	5.80	388	6.87	413	8.00
23688	1400	260	2.30	274	2.77	288	3.21	301	3.71	315	4.20	328	4.72	342	5.25	<u>368</u>	<u>6.35</u>	394	7.46	418	8.63
25380	1500	275	2.69	288	3.18	301	3.67	313	4.16	326	4.69	339	5.23	351	5.79	376	6.92	401	8.10	424	9.32
27072	1600	290	3.13	302	3.65	314	4.18	326	4.70	338	5.23	350	5.79	362	6.36	385	7.56	409	8.80	431	10.07
28764	1700	305	3.64	316	4.16	327	4.72	339	5.28	350	5.82	362	6.41	373	7.00	395	8.24	417	9.53	439	10.85
30456	1800	320	4.20	331	4.72	341	5.31	352	5.89	363	6.48	374	7.09	385	7.70	405	8.98	427	10.32	448	11.69
32148	1900	336	4.79	346	5.35	356	5.97	366	6.60	376	7.21	387	7.83	397	8.46	417	9.78	437	11.17	457	12.59
33840	2000			361	6.04	371	6.67	380	7.34	390	7.99	400	8.63	409	9.29	429	10.64	447	12.08	466	13.55
35532	2100			376	6.82	386	7.44	394	8.14	404	8.83	413	9.51	422	10.19	441	11.59	459	13.05	477	14.57
37224	2200			391	7.66	401	8.29	409	9.00	418	9.73	426	10.44	436	11.17	453	12.59	471	14.09	488	15.67
38916	2300					416	9.20	424	9.93	432	10.69	440	11.44	450	12.20	466	13.69	483	15.21	499	16.82
40608	2400					431	10.22	439	10.95	447	11.73	454	12.54	464	13.30	479	14.86	495	16.36	510	18.10
42300	2500					446	11.32	454	12.05	462	12.83	469	13.65	478	14.48	493	16.11	508	17.77	523	19.46
43992	2600							469	13.21	477	14.01	484	14.94	492	15.74	507	17.43	521	19.12	536	20.81
47376	2800							499	15.89	506	16.67	513	17.60	520	18.44	533	20.30	548	22.17	562	24.03
50760	3000							531	18.95	536	19.80	543	20.64	550	21.49	562	23.52	575	25.55	589	27.41
54144	3200									568	23.18	573	24.20	580	25.04	592	27.07	603	29.27	616	31.30
57528	3400									600	26.90	605	28.09	610	29.10	622	31.13	633	33.33	643	35.53
60912	3600									632	30.63	637	32.32	640	33.50	652	35.53	663	37.73	673	40.10

Volume of Air CFM	Outlet Velocity ft per M	2" SP		2 1/2" SP		3" SP		3 1/2" SP		4" SP		4 1/2" SP		5" SP		5 1/2" SP		6" SP		6 1/2" SP	
		RPM	BHP	RPM	BHP	RPM	BHP	RPM	BHP	RPM	BHP	RPM	BHP	RPM	BHP	RPM	BHP	RPM	BHP	RPM	BHP
16920	1000	435	7.92	486	10.39																
18612	1100	436	8.36	486	10.95																
20304	1200	437	8.82	487	11.54																
21996	1300	439	9.29	488	12.06	533	15.09	575	18.10	615	22.00										
23688	1400	442	9.86	489	12.66	534	15.72	576	18.95	615	22.33										
25380	1500	448	10.58	492	13.28	535	16.40	577	19.80	616	23.18										
27072	1600	454	11.35	496	14.08	538	17.09	578	20.47	617	24.03	653	27.75	688	31.47	721	35.36	753	39.25	784	43.32
28764	1700	460	12.20	502	15.01	541	17.94	580	21.32	618	24.87	654	28.76	689	32.66	722	36.38	754	40.61	784	44.84
30456	1800	468	13.10	508	15.99	546	18.95	583	22.17	620	25.89	655	29.78	690	33.67	723	37.56	754	42.13	784	46.36
32148	1900	476	14.04	515	17.09	552	20.13	588	23.35	623	26.90	657	30.79	691	34.86	724	38.75	755	43.48	785	47.88
33840	2000	485	15.09	522	18.10	558	21.32	593	24.70	627	28.09	660	31.98	693	36.04	725	39.93	756	44.67	786	49.24
35532	2100	495	16.12	530	19.29	565	22.67	599	26.06	632	29.61	664	33.33	696	37.22	727	41.62	757	46.02		
37224	2200	505	17.26	539	20.64	<u>573</u>	<u>24.03</u>	606	27.58	638	31.13	668	34.86	699	38.75	729	42.98	759	47.38		
38916	2300	515	18.44	549	21.83	<u>581</u>	<u>25.38</u>	613	29.10	644	32.82	674	36.55	704	40.44	733	44.50	762	49.07		
40608	2400	527	19.80	559	23.35	590	26.90	<u>621</u>	<u>30.63</u>	651	34.52	680	38.41	709	42.30	737	46.53	765	50.76		
42300	2500	539	21.15	569	24.70	599	28.43	629	32.32	<u>659</u>	<u>36.21</u>	687	40.27	715	44.33	743	48.56	770	52.79		
43992	2600	551	22.50	579	26.23	609	30.12	638	34.01	<u>667</u>	<u>38.07</u>	695	42.13	722	46.36	749	50.59	775	54.99		
47376	2800	575	25.72	603	29.61	629	33.67	657	37.73	684	41.96	710	46.36	737	50.76	762	55.16	787	59.56		
50760	3000	601	29.44	627	33.33	652	37.56	677	41.79	703	46.36	728	50.76	753	55.33	778	60.07	802	64.80		
54144	3200	628	33.33	652	37.56	676	41.79	699	46.36	723	50.93	747	55.67	771	60.40	794	65.31	818	70.39		
57528	3400	655	37.73	679	42.13	701	46.70	723	51.27	745	56.01	768	60.91	790	65.99	812	71.06	835	76.14		
60912	3600	683	42.47	706	47.21	727	51.78	748	56.68	769	61.59	790	66.66	811	71.91	832	77.16				
64296	3800	712	47.71	733	52.79	754	57.70	773	62.60	794	67.68	814	72.93	833	78.34	853	83.75				
67680	4000	742	53.30	760	58.71	781	63.96	800	69.03	819	74.28	838	79.69	858	85.11	876	90.86				

All Capacities Based on Standard Air (Density .075#/cu.ft.—70° F.—29.92" Hg. Bar.)

NOTES: (1) Ball bearings are standard on all Type NH, Class II-A Fans. (2) Values underlined indicate the most efficient point of operation for each pressure. (3) When equipped with Vortex Control increase speed 1%.

**CLASS II-A
MAX. RPM
828**

CLARAGE TYPE NH FANS

**SIZE 120
SINGLE WIDTH
SINGLE INLET**

NON-OVERLOADING MEDIUM SPEED HIGH EFFICIENCY

Outlet Size 48 3/8" x 63 3/8" Outside

Wheel Diameter 60 in.

Inlet Size 65" Dia. Outside

Outlet Area 20.71 Sq. Ft. Inside

Tip Speed = RPM x 15.71

Max. BHP = 223.8 (RPM/1000)³

Volume of Air CFM	Outlet Velocity ft per M	1/4" SP		3/8" SP		1/2" SP		5/8" SP		3/4" SP		7/8" SP		1" SP		1 1/4" SP		1 1/2" SP		1 3/4" SP	
		RPM	BHP	RPM	BHP	RPM	BHP	RPM	BHP	RPM	BHP	RPM	BHP	RPM	BHP	RPM	BHP	RPM	BHP	RPM	BHP
16568	800	163	.97	185	1.35	205	1.74	224	2.15	243	2.63	261	3.15	279	3.69	311	4.83	340	6.03	368	7.25
18639	900	174	1.18	193	1.57	212	2.01	229	2.44	247	2.90	264	3.40	280	3.96	312	5.16	341	6.44	368	7.77
20710	1000	185	1.43	202	1.84	219	2.32	236	2.78	252	3.27	268	3.77	283	4.31	313	5.51	342	6.83	368	8.24
22781	1100	197	1.70	213	2.15	228	2.65	244	3.15	259	3.67	274	4.20	288	4.76	316	5.92	343	7.27	369	8.72
24852	1200	209	2.03	224	2.51	238	3.02	252	3.56	267	4.12	281	4.68	294	5.28	321	6.48	346	7.77	371	9.22
26923	1300	222	2.40	235	2.92	249	3.46	262	4.02	275	4.60	289	5.20	301	5.82	326	7.10	350	8.41	374	9.80
28994	1400	235	2.82	247	3.40	260	3.93	272	4.54	284	5.14	297	5.78	309	6.42	333	7.77	356	9.13	378	10.56
31065	1500	248	3.29	260	3.89	272	4.49	283	5.09	295	5.74	306	6.40	318	7.08	340	8.47	362	9.92	384	11.41
33136	1600	262	3.83	273	4.47	284	5.12	295	5.76	306	6.40	316	7.08	327	7.79	348	9.26	369	10.77	390	12.32
35207	1700	276	4.45	286	5.09	296	5.78	307	6.46	317	7.12	327	7.85	337	8.57	357	10.09	377	11.66	397	13.28
37278	1800	290	5.14	299	5.78	309	6.50	319	7.21	329	7.93	338	8.68	348	9.42	367	11.00	386	12.63	405	14.31
39349	1900	304	5.86	312	6.54	322	7.31	331	8.08	341	8.82	349	9.59	359	10.36	377	11.94	395	13.67	413	15.41
41420	2000			326	7.39	335	8.16	343	8.99	353	9.78	361	10.56	370	11.37	387	13.03	404	14.79	422	16.59
43491	2100			340	8.35	348	9.11	356	9.96	365	10.81	373	11.64	382	12.47	398	14.19	414	15.97	431	17.83
45562	2200			354	9.38	362	10.15	369	11.02	377	11.91	385	12.78	394	13.67	410	15.41	425	17.25	441	19.18
47633	2300					376	11.27	383	12.16	390	13.09	398	14.00	406	14.93	421	16.75	436	18.62	451	20.59
49704	2400					390	12.51	397	13.40	403	14.35	411	15.35	418	16.28	433	18.18	447	20.03	462	22.16
51775	2500					404	13.85	411	14.75	417	15.70	424	16.71	431	17.73	445	19.72	459	21.75	473	23.82
53846	2600							425	16.17	431	17.15	437	18.29	444	19.26	458	21.33	471	23.40	484	25.47
57988	2800							452	19.45	458	20.40	463	21.54	470	22.57	482	24.85	495	27.13	508	29.41
62130	3000							480	23.20	485	24.23	490	25.27	497	26.30	508	28.79	520	31.27	532	33.55
66272	3200									513	28.37	518	29.62	524	30.65	535	33.14	545	35.83	557	38.31
70414	3400									542	32.93	546	34.38	551	35.62	562	38.11	572	40.80	582	43.49
74556	3600									571	37.49	575	39.56	579	41.01	589	43.49	599	46.18	608	49.08

Volume of Air CFM	Outlet Velocity ft per M	2" SP		2 1/2" SP		3" SP		3 1/2" SP		4" SP		4 1/2" SP		5" SP		5 1/2" SP		6" SP		6 1/2" SP	
		RPM	BHP	RPM	BHP	RPM	BHP	RPM	BHP	RPM	BHP	RPM	BHP	RPM	BHP	RPM	BHP	RPM	BHP	RPM	BHP
20710	1000	393	9.7	439	12.7																
22781	1100	394	10.2	440	13.4																
24852	1200	395	10.8	440	14.1																
26923	1300	397	11.4	441	14.8	482	18.5	520	22.2	556	26.9										
28994	1400	400	12.1	442	15.5	483	19.2	521	23.2	556	27.3										
31065	1500	405	12.9	445	16.3	484	20.1	522	24.2	557	28.4										
33136	1600	410	13.9	449	17.2	486	20.9	523	25.1	557	29.4	591	34.0	622	38.5	652	43.3	681	48.0	708	53.0
35207	1700	416	14.9	453	18.4	489	22.0	524	26.1	558	30.4	591	35.2	623	40.0	652	44.5	681	49.7	709	54.9
37278	1800	423	16.0	459	19.6	494	23.2	527	27.1	560	31.7	592	36.4	623	41.2	653	46.0	682	51.6	709	56.7
39349	1900	431	17.2	465	20.9	499	24.6	531	28.6	563	32.9	594	37.7	624	42.7	654	47.4	682	53.2	710	58.6
41420	2000	439	18.5	472	22.2	504	26.1	536	30.2	566	34.4	596	39.1	626	44.1	655	48.9	683	54.7	710	60.3
43491	2100	447	19.7	480	23.6	511	27.8	541	31.9	571	36.2	600	40.8	629	45.6	657	50.9	684	56.3		
45562	2200	456	21.1	488	25.3	518	29.4	547	33.8	576	38.1	604	42.7	632	47.4	659	52.6	686	58.0		
47633	2300	466	22.6	496	26.7	525	31.1	554	35.6	582	40.2	609	44.7	636	49.5	662	54.5	688	60.1		
49704	2400	476	24.2	505	28.6	533	32.9	561	37.5	588	42.2	615	47.0	641	51.8	666	57.0	692	62.1		
51775	2500	487	25.9	514	30.2	541	34.8	569	39.6	595	44.3	621	49.3	646	54.3	671	59.4	696	64.6		
53846	2600	498	27.5	524	32.1	550	36.9	577	41.6	603	46.6	628	51.6	652	56.7	677	61.9	701	67.3		
57988	2800	520	31.5	545	36.2	569	41.2	594	46.2	618	51.4	642	56.7	666	62.1	689	67.5	712	72.9		
62130	3000	544	36.0	567	40.8	589	46.0	612	51.2	635	56.7	658	62.1	681	67.7	703	73.5	725	79.3		
66272	3200	568	40.8	590	46.0	611	51.2	632	56.7	654	62.3	675	68.1	697	73.9	718	79.9	739	86.2		
70414	3400	592	46.2	614	51.6	634	57.2	654	62.8	674	68.6	694	74.6	714	80.8	734	87.0	755	93.2		
74556	3600	617	52.0	638	57.8	657	63.4	676	69.4	696	75.4	714	81.6	733	88.0	752	94.4				
78698	3800	643	58.4	662	64.6	681	70.6	699	76.6	718	82.8	736	89.3	753	95.9	771	102.5				
82840	4000	671	65.2	687	71.9	706	78.3	723	84.5	740	90.9	758	97.5	775	104.2	792	111.2				

All Capacities Based on Standard Air (Density .075#/cu.ft.—70° F.—29.92" Hg. Bar.)

NOTES: (1) Ball bearings are standard on all Type NH, Class II-A Fans. (2) Values underlined indicate the most efficient point of operation for each pressure. (3) When equipped with Vortex Control increase speed 1%.

SIZE 132
SINGLE WIDTH
SINGLE INLET

CLARAGE TYPE NH FANS

CLASS II-A
MAX. RPM
753

NON-OVERLOADING MEDIUM SPEED HIGH EFFICIENCY

Outlet Size 53 1/8" x 69 5/8" Outside

Wheel Diameter 66 in.

Inlet Size 72" Dia. Outside

Outlet Area 25.05 Sq. Ft. Inside

Tip Speed = RPM x 17.28

Max. BHP = 360.4 (RPM/1000)³

Volume of Air CFM	Outlet Velocity ft per M	1/4" SP		3/8" SP		1/2" SP		5/8" SP		3/4" SP		7/8" SP		1" SP		1 1/4" SP		1 1/2" SP		1 3/4" SP	
		RPM	BHP	RPM	BHP	RPM	BHP	RPM	BHP	RPM	BHP	RPM	BHP	RPM	BHP	RPM	BHP	RPM	BHP	RPM	BHP
20040	800	149	1.18	168	1.63	186	2.10	204	2.61	221	3.18	238	3.81	253	4.46	283	5.84	309	7.29	334	8.77
22545	900	158	1.43	175	1.90	192	2.43	209	2.96	224	3.51	240	4.11	255	4.78	283	6.24	310	7.79	334	9.39
25050	1000	168	1.73	184	2.23	199	2.81	215	3.36	229	3.96	244	4.56	257	5.21	285	6.66	311	8.27	335	9.97
27555	1100	179	2.05	193	2.61	207	3.21	222	3.81	235	4.43	249	5.09	262	5.76	287	7.16	312	8.79	336	10.55
30060	1200	190	2.45	203	3.03	216	3.66	229	4.31	242	4.98	255	5.66	267	6.39	291	7.84	314	9.39	337	11.15
32565	1300	202	2.91	214	3.53	226	4.18	238	4.86	250	5.56	262	6.29	274	7.04	297	8.59	319	10.17	340	11.85
35070	1400	214	3.41	225	4.11	236	4.76	248	5.49	259	6.21	270	6.99	281	7.77	303	9.39	324	11.05	344	12.78
37575	1500	226	3.98	236	4.71	247	5.44	258	6.16	268	6.94	278	7.74	289	8.57	309	10.25	329	12.00	349	13.80
40080	1600	238	4.63	248	5.41	258	6.19	268	6.96	278	7.74	287	8.57	297	9.42	317	11.20	336	13.03	355	14.90
42585	1700	250	5.39	260	6.16	269	6.99	279	7.82	288	8.62	297	9.49	306	10.37	325	12.20	343	14.10	361	16.06
45090	1800	263	6.21	272	6.99	280	7.87	290	8.72	299	9.59	307	10.50	316	11.40	333	13.30	351	15.28	368	17.31
47595	1900	276	7.09	284	7.92	292	8.84	301	9.77	310	10.67	318	11.60	326	12.53	342	14.48	359	16.53	375	18.64
50100	2000			296	8.94	304	9.87	312	10.87	321	11.82	329	12.78	336	13.75	352	15.76	368	17.89	383	20.07
52605	2100			309	10.10	316	11.02	324	12.05	332	13.08	340	14.08	347	15.08	362	17.16	377	19.31	392	21.57
55110	2200			322	11.35	328	12.27	336	13.33	343	14.40	351	15.46	358	16.53	372	18.64	387	20.87	401	23.20
57615	2300					341	13.63	348	14.70	355	15.83	362	16.93	369	18.06	383	20.27	397	22.52	410	24.90
60120	2400					354	15.13	360	16.21	367	17.36	373	18.56	380	19.69	394	21.99	407	24.22	420	26.80
62625	2500					367	16.76	372	17.84	379	18.99	385	20.22	391	21.44	405	23.85	417	26.30	430	28.81
65130	2600							385	19.56	392	20.74	398	22.12	403	23.30	416	25.80	428	28.30	440	30.81
70140	2800							410	23.52	416	24.67	422	26.05	427	27.30	438	30.06	450	32.82	462	35.57
75150	3000							436	28.06	441	29.31	446	30.56	451	31.81	462	34.82	473	37.83	484	40.58
80160	3200									467	34.32	471	35.82	476	37.07	486	40.08	496	43.34	506	46.34
85170	3400									493	39.83	497	41.58	501	43.09	510	46.09	520	49.35	529	52.61
90180	3600									519	45.34	523	47.85	526	49.60	535	52.61	545	55.86	553	59.37

Volume of Air CFM	Outlet Velocity ft per M	2" SP		2 1/2" SP		3" SP		3 1/2" SP		4" SP		4 1/2" SP		5" SP		5 1/2" SP		6" SP		6 1/2" SP	
		RPM	BHP	RPM	BHP	RPM	BHP	RPM	BHP	RPM	BHP	RPM	BHP	RPM	BHP	RPM	BHP	RPM	BHP	RPM	BHP
25050	1000	358	11.7	399	15.4																
27555	1100	358	12.4	400	16.2																
30060	1200	359	13.1	400	17.1																
32565	1300	361	13.8	401	17.9	438	22.3	473	26.8	505	32.6										
35070	1400	364	14.6	402	18.7	439	23.3	473	28.1	506	33.1										
37575	1500	368	15.7	404	19.7	440	24.3	474	29.3	506	34.3										
40080	1600	373	16.8	408	20.8	442	25.3	475	30.3	507	35.6	537	41.1	565	46.6	593	52.4	619	58.1	644	64.1
42585	1700	378	18.1	412	22.2	445	26.6	477	31.6	508	36.8	538	42.6	566	48.3	593	53.9	619	60.1	644	66.4
45090	1800	385	19.4	417	23.7	449	28.1	479	32.8	509	38.3	539	44.1	567	49.8	594	55.6	620	62.4	645	68.6
47595	1900	392	20.8	423	25.3	453	29.8	483	34.6	512	39.8	540	45.6	568	51.6	595	57.4	620	64.4	645	70.9
50100	2000	399	22.3	429	26.8	459	31.6	487	36.6	515	41.6	542	47.3	569	53.4	596	59.1	621	66.1	646	72.9
52605	2100	407	23.9	436	28.6	465	33.6	492	38.6	519	43.8	545	49.3	571	55.1	597	61.6	622	68.1		
55110	2200	415	25.6	443	30.6	471	35.6	498	40.8	524	46.1	549	51.6	574	57.4	599	63.6	624	70.1		
57615	2300	424	27.3	451	32.3	478	37.6	504	43.1	529	48.6	554	54.1	578	59.9	602	65.9	626	72.6		
60120	2400	433	29.3	459	34.6	485	39.8	510	45.3	535	51.1	559	56.9	583	62.6	606	68.9	629	75.2		
62625	2500	443	31.3	467	36.6	492	42.1	517	47.8	541	53.6	565	59.6	588	65.6	610	71.9	633	78.2		
65130	2600	453	33.3	476	38.8	500	44.6	524	50.4	548	56.4	571	62.4	593	68.6	615	74.9	637	81.4		
70140	2800	473	38.1	495	43.8	517	49.8	540	55.9	562	62.1	584	68.6	605	75.2	626	81.7	647	88.2		
75150	3000	494	43.6	515	49.3	536	55.6	556	61.9	578	68.6	594	75.4	614	82.4	634	89.4	653	95.9		
80160	3200	516	49.3	536	55.6	556	61.9	575	68.6	594	75.4	614	82.4	634	89.4	653	96.7	672	104.2		
85170	3400	538	55.9	558	62.4	576	69.1	594	75.9	613	82.9	631	90.2	650	97.7	667	105.2	686	112.7		
90180	3600	561	62.9	580	69.9	597	76.7	615	83.9	632	91.2	649	98.7	666	106.5	684	114.2				
95190	3800	585	70.6	602	78.2	619	85.4	636	92.7	652	100.2	669	108.0	685	116.0	701	124.0				
100200	4000	610	78.9	625	86.9	642	94.7	657	102.2	673	110.0	689	118.0	705	126.0	720	134.5				

All Capacities Based on Standard Air (Density .075#/cu.ft.—70° F.—29.92" Hg. Bar.)

NOTES: (1) Ball bearings are standard on all Type NH, Class II-A Fans. (2) Values underlined indicate the most efficient point of operation for each pressure. (3) When equipped with Vortex Control increase speed 1%.

CLASS II-A
MAX. RPM
3310

CLARAGE TYPE NH FANS

SIZE 30
DOUBLE WIDTH
DOUBLE INLET

NON-OVERLOADING MEDIUM SPEED HIGH EFFICIENCY

Outlet Size 21½" x 15⅜" Outside

Wheel Diameter 15 in.

Inlet Size 18¼" Dia. Outside

Outlet Area 2.30 Sq. Ft. Inside

Tip Speed = RPM × 3.93

Max. BHP = .41 $\left(\frac{\text{RPM}}{1000}\right)^3$

Volume of Air CFM	Outlet Velocity ft per M	¼" SP		⅜" SP		½" SP		⅝" SP		¾" SP		⅞" SP		1" SP		1¼" SP		1½" SP		1¾" SP	
		RPM	BHP	RPM	BHP	RPM	BHP	RPM	BHP	RPM	BHP	RPM	BHP	RPM	BHP	RPM	BHP	RPM	BHP	RPM	BHP
1840	800	666	.122	762	.166	832	.214	913	.267	992	.322	1065	.382	1135	.446	1264	.584	1381	.729	1488	.883
2070	900	709	.147	783	.196	857	.246	931	.301	1004	.359	1075	.421	1143	.488	1270	.628	1386	.780	1493	.938
2300	1000	754	.179	823	.230	890	.283	957	.340	1023	.400	1089	.465	1154	.534	1276	.676	1392	.835	1498	.998
2530	1100	801	.214	867	.271	928	.327	989	.386	1050	.449	1110	.515	1170	.587	1288	.734	1399	.892	1505	1.06
2760	1200	849	.255	912	.317	971	.377	1026	.439	1082	.506	1137	.573	1192	.646	1303	.798	1410	.961	1512	1.13
2990	1300	898	.304	958	.368	1015	.435	1068	.501	1118	.568	1169	.639	1220	.713	1323	.869	1425	1.04	1524	1.21
3220	1400	949	.357	1006	.426	1060	.497	1111	.568	1159	.639	1206	.713	1253	.789	1348	.950	1444	1.12	1538	1.30
3450	1500	1001	.416	1054	.492	1106	.566	1156	.642	1202	.718	1247	.796	1290	.874	1379	1.04	1468	1.21	1557	1.40
3680	1600	1054	.483	1104	.564	1153	.642	1201	.722	1247	.803	1290	.886	1331	.968	1415	1.14	1498	1.32	1580	1.51
3910	1700	1107	.557	1155	.644	1202	.727	1247	.812	1292	.897	1334	.984	1374	1.07	1452	1.25	1531	1.43	1608	1.63
4140	1800	1160	.642	1207	.731	1251	.821	1294	.911	1337	.998	1379	1.09	1418	1.18	1492	1.37	1566	1.56	1640	1.75
4370	1900	1216	.734	1259	.826	1302	.922	1343	1.02	1384	1.11	1424	1.21	1462	1.30	1536	1.50	1606	1.69	1675	1.90
4600	2000			1312	.932	1352	1.03	1392	1.13	1432	1.23	1470	1.33	1508	1.43	1580	1.63	1648	1.84	1713	2.05
4830	2100			1365	1.05	1405	1.15	1442	1.26	1480	1.36	1518	1.47	1554	1.57	1625	1.78	1691	2.00	1754	2.21
5060	2200			1418	1.17	1456	1.28	1493	1.39	1530	1.50	1566	1.61	1601	1.72	1670	1.94	1735	2.16	1797	2.39
5290	2300					1510	1.42	1545	1.54	1580	1.65	1615	1.76	1649	1.88	1716	2.11	1779	2.35	1840	2.58
5520	2400					1563	1.57	1597	1.69	1631	1.81	1664	1.93	1697	2.05	1762	2.29	1825	2.53	1884	2.78
5750	2500					1616	1.73	1650	1.86	1682	1.98	1715	2.11	1746	2.24	1809	2.48	1871	2.74	1929	2.99
5980	2600							1703	2.04	1735	2.17	1766	2.30	1796	2.44	1858	2.69	1917	2.94	1974	3.20
6440	2800							1810	2.44	1841	2.58	1870	2.71	1898	2.85	1955	3.13	2011	3.40	2068	3.68
6900	3000							1920	2.90	1948	3.04	1975	3.17	2003	3.34	2056	3.63	2109	3.93	2161	4.23
7360	3200									2053	3.54	2081	3.70	2108	3.86	2158	4.19	2208	4.51	2257	4.83
7820	3400									2163	4.14	2189	4.30	2214	4.46	2263	4.81	2309	5.15	2356	5.50
8280	3600									2284	4.81	2302	4.97	2320	5.13	2368	5.47	2414	5.84	2458	6.21

Volume of Air CFM	Outlet Velocity ft per M	2" SP		2½" SP		3" SP		3½" SP		4" SP		4½" SP		5" SP		5½" SP		6" SP		6½" SP	
		RPM	BHP	RPM	BHP	RPM	BHP	RPM	BHP	RPM	BHP	RPM	BHP	RPM	BHP	RPM	BHP	RPM	BHP	RPM	BHP
2300	1000	1598	1.17	1781	1.54																
2530	1100	1604	1.24	1786	1.62																
2760	1200	1610	1.32	1791	1.71																
2990	1300	1619	1.40	1797	1.81	1961	2.23	2113	2.69	2254	3.17										
3220	1400	1630	1.49	1805	1.90	1968	2.35	2119	2.81	2259	3.29										
3450	1500	1645	1.59	1815	2.01	1974	2.46	2125	2.92	2265	3.43										
3680	1600	1663	1.71	1827	2.13	1983	2.58	2131	3.06	2270	3.57	2403	4.12	2528	4.67	2647	5.24	2761	5.82	2872	6.44
3910	1700	1686	1.83	1843	2.26	1994	2.71	2140	3.22	2277	3.73	2409	4.28	2534	4.83	2652	5.43	2766	6.03	2876	6.65
4140	1800	1714	1.96	1863	2.39	2009	2.88	2151	3.38	2285	3.89	2415	4.44	2540	5.01	2658	5.61	2772	6.23	2881	6.85
4370	1900	1745	2.11	1886	2.55	2026	3.04	2164	3.54	2295	4.07	2423	4.62	2546	5.20	2664	5.82	2778	6.44	2886	7.08
4600	2000	1779	2.27	1913	2.71	2047	3.20	2179	3.73	2308	4.26	2433	4.83	2553	5.41	2670	6.03	2784	6.67	2892	7.34
4830	2100	1815	2.44	1943	2.90	2070	3.38	2198	3.91	2323	4.46	2445	5.04	2564	5.64	2679	6.26	2791	6.90		
5060	2200	1856	2.62	1977	3.08	2099	3.59	2220	4.12	2340	4.69	2459	5.27	2576	5.87	2689	6.51	2798	7.15		
5290	2300	1896	2.81	2014	3.29	2131	3.82	2247	4.35	2362	4.92	2476	5.50	2590	6.12	2701	6.76	2808	7.41		
5520	2400	1938	3.01	2052	3.52	2164	4.05	2276	4.58	2386	5.15	2496	5.75	2606	6.37	2714	7.02	2820	7.68		
5750	2500	1981	3.24	2090	3.75	2197	4.28	2304	4.83	2411	5.43	2518	6.03	2625	6.67	2730	7.31	2834	7.98		
5980	2600	2024	3.47	2128	4.00	2233	4.55	2336	5.11	2440	5.70	2543	6.33	2646	6.97	2748	7.61	2850	8.30		
6440	2800	2120	3.98	2222	4.53	2318	5.11	2412	5.70	2507	6.30	2601	6.95	2695	7.59	2789	8.28	2883	8.97		
6900	3000	2213	4.53	2311	5.13	2405	5.75	2494	6.37	2581	6.99	2668	7.64	2757	8.30	2846	9.02	2935	9.73		
7360	3200	2306	5.15	2402	5.77	2493	6.44	2580	7.08	2663	7.75	2745	8.42	2826	9.11	2909	9.82	2992	10.53		
7820	3400	2403	5.82	2494	6.49	2583	7.18	2668	7.87	2749	8.56	2827	9.27	2904	9.98	2981	10.72	3058	11.45		
8280	3600	2501	6.58	2588	7.27	2675	7.98	2758	8.72	2836	9.45	2913	10.19	2987	10.95	3059	11.68				
8740	3800	2604	7.38	2687	8.14	2768	8.88	2850	9.66	2926	10.42	3001	11.18	3073	11.96	3143	12.74				
9200	4000	2707	8.26	2785	9.06	2864	9.84	2942	10.65	3017	11.45	3089	12.26	3160	13.06	3229	13.89				

All Capacities Based on Standard Air (Density .075#/cu.ft.—70° F.—29.92" Hg. Bar.)

NOTES: (1) Ball bearings are standard on all Type NH, Class II-A Fans. (2) Values underlined indicate the most efficient point of operation for each pressure. (3) When equipped with Vortex Control increase speed 1%.

SIZE 33
DOUBLE WIDTH
DOUBLE INLET

CLARAGE TYPE NH FANS

CLASS II-A
MAX. RPM
3010

NON-OVERLOADING MEDIUM SPEED HIGH EFFICIENCY

Outlet Size 23³/₈" x 17⁵/₁₆" Outside

Wheel Diameter 16¹/₂ in.

Inlet Size 19³/₄" Dia. Outside

Outlet Area 2.80 Sq. Ft. Inside

Tip Speed = RPM x 4.32

Max. BHP = .66 (RPM/1000)³

Volume of Air CFM	Outlet Velocity ft per M	1/4" SP		3/8" SP		1/2" SP		5/8" SP		3/4" SP		7/8" SP		1" SP		1 1/4" SP		1 1/2" SP		1 3/4" SP	
		RPM	BHP	RPM	BHP	RPM	BHP	RPM	BHP	RPM	BHP	RPM	BHP	RPM	BHP	RPM	BHP	RPM	BHP	RPM	BHP
2240	800	606	.148	681	.202	757	.260	831	.325	902	.392	969	.465	1033	.543	1150	.711	1256	.888	1354	1.08
2520	900	645	.179	712	.238	780	.300	847	.367	914	.437	978	.512	1040	.594	1155	.764	1261	.949	1358	1.14
2800	1000	686	.218	749	.280	810	.344	870	.414	931	.487	991	.566	1050	.650	1161	.823	1266	1.02	1363	1.22
3080	1100	728	.260	789	.330	844	.398	900	.470	955	.546	1010	.627	1065	.714	1172	.893	1273	1.09	1369	1.30
3360	1200	772	.311	830	.386	883	.459	934	.535	984	.616	1034	.697	1084	.787	1185	.972	1283	1.17	1376	1.38
3640	1300	817	.370	872	.448	923	.529	971	.610	1017	.692	1063	.778	1110	.868	1204	1.06	1296	1.26	1386	1.48
3920	1400	863	.434	915	.518	964	.605	1011	.692	1054	.778	1096	.868	1140	.960	1227	1.16	1314	1.36	1399	1.58
4200	1500	911	.507	959	.599	1006	.689	1051	.781	1094	.874	1134	.969	1174	1.06	1254	1.27	1335	1.48	1417	1.71
4480	1600	959	.588	1004	.686	1049	.781	1093	.879	1134	.977	1173	1.08	1211	1.18	1287	1.39	1362	1.60	1438	1.84
4760	1700	1007	.678	1050	.784	1093	.885	1135	.988	1175	1.09	1213	1.20	1250	1.30	1321	1.52	1392	1.74	1463	1.98
5040	1800	1055	.781	1098	.890	1138	1.00	1178	1.11	1217	1.22	1254	1.33	1290	1.44	1357	1.66	1425	1.90	1492	2.14
5320	1900	1106	.893	1146	1.01	1184	1.23	1222	1.24	1259	1.35	1296	1.47	1330	1.58	1397	1.82	1461	2.06	1524	2.31
5600	2000			1194	1.13	1230	1.26	1267	1.38	1303	1.50	1338	1.62	1372	1.74	1437	1.99	1499	2.24	1559	2.49
5880	2100			1242	1.27	1278	1.40	1312	1.53	1347	1.65	1381	1.79	1414	1.91	1478	2.17	1538	2.43	1596	2.69
6160	2200			1290	1.43	1325	1.56	1358	1.69	1391	1.83	1425	1.96	1457	2.09	1519	2.36	1578	2.63	1635	2.91
6440	2300					1373	1.73	1406	1.87	1437	2.01	1469	2.15	1500	2.29	1561	2.57	1619	2.86	1674	3.14
6720	2400					1422	1.91	1453	2.06	1484	2.21	1514	2.35	1544	2.50	1603	2.79	1660	3.08	1714	3.39
7000	2500					1470	2.11	1501	2.26	1531	2.42	1560	2.57	1589	2.72	1646	3.02	1702	3.33	1755	3.64
7280	2600							1550	2.48	1579	2.64	1606	2.80	1634	2.97	1690	3.28	1744	3.58	1796	3.89
7840	2800							1646	2.97	1675	3.13	1701	3.30	1727	3.47	1778	3.81	1830	4.14	1881	4.48
8400	3000							1747	3.53	1772	3.70	1797	3.86	1822	4.06	1870	4.42	1918	4.79	1966	5.15
8960	3200									1868	4.31	1893	4.51	1918	4.70	1963	5.10	2009	5.49	2053	5.88
9520	3400									1968	5.04	1991	5.24	2014	5.43	2058	5.85	2101	6.27	2144	6.69
10080	3600									2078	5.85	2094	6.05	2110	6.24	2154	6.66	2196	7.11	2236	7.56

Volume of Air CFM	Outlet Velocity ft per M	2" SP		2 1/2" SP		3" SP		3 1/2" SP		4" SP		4 1/2" SP		5" SP		5 1/2" SP		6" SP		6 1/2" SP	
		RPM	BHP	RPM	BHP	RPM	BHP	RPM	BHP	RPM	BHP	RPM	BHP	RPM	BHP	RPM	BHP	RPM	BHP	RPM	BHP
2800	1000	1454	1.43	1620	1.88																
3080	1100	1459	1.51	1625	1.97																
3360	1200	1465	1.60	1629	2.08																
3640	1300	1472	1.71	1635	2.20	1784	2.72	1923	3.28	2051	3.86										
3920	1400	1483	1.82	1642	2.31	1790	2.86	1928	3.42	2055	4.00										
4200	1500	1497	1.94	1651	2.45	1796	3.00	1933	3.56	2060	4.17										
4480	1600	1513	2.08	1662	2.59	1804	3.14	1939	3.72	2066	4.34	2186	5.01	2300	5.68	2408	6.38	2512	7.08	2612	7.84
4760	1700	1534	2.23	1677	2.75	1814	3.30	1947	3.92	2071	4.54	2191	5.21	2305	5.88	2413	6.61	2517	7.34	2616	8.09
5040	1800	1559	2.39	1694	2.91	1827	3.50	1956	4.12	2079	4.73	2197	5.33	2310	6.10	2418	6.83	2521	7.59	2621	8.34
5320	1900	1587	2.56	1716	3.11	1843	3.70	1968	4.31	2088	4.96	2204	5.63	2316	6.33	2424	7.08	2527	7.84	2626	8.62
5600	2000	1618	2.76	1740	3.30	1862	3.89	1983	4.54	2100	5.18	2213	5.88	2322	6.58	2429	7.34	2533	8.12	2631	8.93
5880	2100	1651	2.97	1767	3.53	1884	4.12	2000	4.76	2113	5.43	2224	6.13	2332	6.86	2437	7.62	2539	8.40		
6160	2200	1688	3.19	1799	3.75	1909	4.37	2020	5.01	2129	5.71	2237	6.41	2343	7.14	2446	7.92	2546	8.71		
6440	2300	1725	3.42	1832	4.00	1939	4.65	2044	5.29	2149	5.99	2253	6.69	2356	7.45	2457	8.23	2555	9.02		
6720	2400	1763	3.67	1867	4.28	1969	4.93	2070	5.57	2170	6.27	2271	7.00	2371	7.76	2469	8.54	2566	9.35		
7000	2500	1802	3.95	1901	4.56	1999	5.21	2096	5.88	2194	6.61	2291	7.34	2388	8.12	2484	8.90	2578	9.72		
7280	2600	1841	4.23	1936	4.87	2031	5.54	2125	6.22	2220	6.94	2314	7.70	2407	8.48	2500	9.27	2592	10.11		
7840	2800	1929	4.84	2021	5.52	2109	6.22	2195	6.94	2281	7.67	2366	8.46	2452	9.24	2537	10.08	2622	10.92		
8400	3000	2013	5.52	2102	6.24	2188	7.00	2269	7.76	2348	8.51	2428	9.30	2508	10.11	2589	10.98	2670	11.84		
8960	3200	2098	6.27	2185	7.03	2268	7.84	2347	8.62	2422	9.44	2497	10.25	2571	11.09	2647	11.96	2722	12.82		
9520	3400	2186	7.08	2269	7.90	2350	8.74	2427	9.58	2500	10.42	2571	11.28	2642	12.15	2712	13.05	2781	13.94		
10080	3600	2275	8.01	2354	8.85	2433	9.72	2509	10.61	2580	11.51	2650	12.40	2717	13.33	2783	14.22				
10640	3800	2369	8.99	2444	9.91	2519	10.81	2593	11.76	2662	12.68	2730	13.61	2795	14.56	2859	15.51				
11200	4000	2462	10.05	2534	11.03	2606	11.98	2676	12.96	2744	13.94	2810	14.92	2875	15.90	2937	16.91				

All Capacities Based on Standard Air (Density .075#/cu.ft.—70° F.—29.92" Hg. Bar.)

NOTES: (1) Ball bearings are standard on all Type NH, Class II-A Fans. (2) Values underlined indicate the most efficient point of operation for each pressure. (3) When equipped with Vortex Control increase speed 1%.

**CLASS II-A
MAX. RPM
2720**

CLARAGE TYPE NH FANS

NON-OVERLOADING MEDIUM SPEED HIGH EFFICIENCY

**SIZE 36 1/2
DOUBLE WIDTH
DOUBLE INLET**

Outlet Size 26 1/8" x 19 3/8" Outside

Wheel Diameter 18 1/4 in.

Inlet Size 22" Dia. Outside

Outlet Area 3.42 Sq. Ft. Inside

Tip Speed = RPM x 4.78

Max. BHP = 1.11 (RPM/1000)³

Volume of Air CFM	Outlet Velocity Feet per Minute	1/4" SP		3/8" SP		1/2" SP		5/8" SP		3/4" SP		7/8" SP		1" SP		1 1/4" SP		1 1/2" SP		1 3/4" SP	
		RPM	BHP	RPM	BHP	RPM	BHP	RPM	BHP	RPM	BHP	RPM	BHP	RPM	BHP	RPM	BHP	RPM	BHP	RPM	BHP
2736	800	534	.17	609	.23	683	.30	753	.38	817	.47	877	.56	935	.65	1041	.84	1137	1.07	1226	1.29
3078	900	568	.20	632	.27	699	.34	765	.42	827	.52	885	.61	941	.70	1045	.91	1141	1.13	1230	1.36
3420	1000	602	.24	662	.32	721	.39	780	.48	840	.56	897	.66	951	.76	1051	.98	1146	1.20	1234	1.44
3762	1100	639	.29	695	.37	747	.45	801	.54	856	.63	910	.73	962	.83	1061	1.07	1152	1.29	1239	1.54
4104	1200	676	.34	729	.43	779	.52	827	.61	877	.70	926	.80	976	.91	1073	1.14	1162	1.39	1246	1.64
4446	1300	713	.40	765	.50	812	.59	858	.69	902	.79	948	.89	994	1.00	1085	1.23	1173	1.49	1255	1.75
4788	1400	755	.47	802	.57	846	.67	890	.77	931	.88	973	.98	1016	1.09	1101	1.33	1186	1.59	1267	1.86
5130	1500	797	.55	840	.65	883	.76	924	.87	964	.98	1002	1.09	1041	1.21	1120	1.45	1200	1.70	1279	1.98
5472	1600	840	.65	878	.75	920	.86	959	.97	998	1.09	1034	1.21	1070	1.33	1144	1.58	1219	1.84	1293	2.12
5814	1700	884	.75	918	.86	957	.97	995	1.09	1032	1.21	1068	1.34	1103	1.46	1170	1.72	1241	1.99	1311	2.26
6156	1800	930	.86	960	.97	994	1.09	1033	1.22	1068	1.34	1102	1.48	1136	1.61	1200	1.87	1265	2.15	1332	2.44
6498	1900	976	.98	1003	1.10	1033	1.22	1071	1.35	1105	1.49	1137	1.62	1170	1.76	1232	2.05	1293	2.33	1355	2.63
6840	2000			1046	1.25	1076	1.37	1109	1.50	1142	1.64	1173	1.79	1204	1.93	1266	2.23	1324	2.52	1381	2.83
7182	2100			1091	1.40	1119	1.54	1147	1.67	1180	1.81	1210	1.96	1241	2.11	1299	2.42	1357	2.73	1411	3.04
7524	2200			1139	1.57	1162	1.71	1188	1.85	1216	1.99	1248	2.15	1278	2.31	1334	2.63	1390	2.94	1443	3.27
7866	2300					1205	1.89	1230	2.05	1255	2.19	1285	2.35	1315	2.51	1369	2.84	1423	3.18	1476	3.52
8208	2400					1249	2.11	1272	2.25	1297	2.41	1322	2.57	1352	2.73	1406	3.07	1457	3.42	1509	3.77
8550	2500					1296	2.33	1314	2.48	1338	2.65	1363	2.80	1390	2.97	1443	3.32	1493	3.69	1543	4.05
8892	2600							1359	2.73	1382	2.88	1405	3.05	1428	3.22	1481	3.59	1530	3.93	1577	4.34
9576	2800							1450	3.26	1466	3.42	1490	3.63	1510	3.80	1555	4.17	1604	4.55	1649	4.99
10260	3000							1541	3.86	1557	4.07	1575	4.28	1594	4.45	1632	4.82	1678	5.23	1724	5.64
10944	3200									1648	4.75	1663	4.96	1678	5.16	1718	5.57	1753	5.99	1799	6.40
11628	3400									1739	5.54	1753	5.75	1769	5.99	1804	6.40	1837	6.84	1874	7.28
12312	3600									1828	6.43	1843	6.63	1862	6.87	1889	7.32	1924	7.80	1952	8.24

Volume of Air CFM	Outlet Velocity Feet per Minute	2" SP		2 1/2" SP		3" SP		3 1/2" SP		4" SP		4 1/2" SP		5" SP		5 1/2" SP		6" SP		6 1/2" SP	
		RPM	BHP	RPM	BHP	RPM	BHP	RPM	BHP	RPM	BHP	RPM	BHP	RPM	BHP	RPM	BHP	RPM	BHP	RPM	BHP
3420	1000	1316	1.70	1467	2.24																
3762	1100	1321	1.79	1471	2.34																
4104	1200	1326	1.90	1475	2.46																
4446	1300	1333	2.02	1480	2.59	1615	3.22	1740	3.99	1857	4.62										
4788	1400	1343	2.15	1486	2.74	1620	3.38	1744	4.07	1861	4.79										
5130	1500	1355	2.28	1494	2.90	1626	3.55	1749	4.24	1865	4.96										
5472	1600	1367	2.41	1505	3.06	1633	3.73	1754	4.41	1870	5.16	1979	5.92	2082	6.77	2180	7.63	2275	8.52	2365	9.44
5814	1700	1381	2.57	1517	3.22	1643	3.92	1762	4.62	1875	5.37	1984	6.16	2086	7.01	2184	7.83	2279	8.72	2369	9.68
6156	1800	1398	2.74	1530	3.39	1654	4.12	1771	4.85	1882	5.61	1989	6.43	2091	7.27	2189	8.07	2283	8.99	2373	9.95
6498	1900	1419	2.93	1544	3.59	1666	4.32	1782	5.08	1891	5.85	1996	6.70	2096	7.54	2194	8.33	2287	9.27	2377	10.23
6840	2000	1441	3.14	1561	3.81	1679	4.52	1794	5.31	1901	6.09	2004	6.98	2103	7.83	2199	8.63	2292	9.61	2382	10.57
7182	2100	1466	3.37	1581	4.05	1694	4.75	1806	5.55	1913	6.34	2014	7.26	2112	8.14	2205	9.00	2298	9.95		
7524	2200	1494	3.60	1603	4.30	1712	5.02	1819	5.83	1925	6.60	2025	7.54	2122	8.48	2214	9.36	2305	10.31		
7866	2300	1526	3.86	1627	4.55	1732	5.30	1835	6.11	1938	6.88	2037	7.85	2133	8.78	2225	9.73	2313	10.69		
8208	2400	1558	4.14	1654	4.85	1754	5.61	1853	6.40	1952	7.22	2050	8.16	2145	9.10	2236	10.10	2323	11.05		
8550	2500	1591	4.42	1683	5.16	1778	5.95	1874	6.76	1968	7.58	2064	8.52	2157	9.44	2248	10.47	2334	11.46		
8892	2600	1625	4.72	1714	5.47	1803	6.29	1896	7.12	1988	7.94	2079	8.88	2171	9.82	2260	10.84	2346	11.87		
9576	2800	1693	5.37	1780	6.19	1863	7.05	1946	7.90	2032	8.79	2117	9.68	2202	10.64	2286	11.63	2371	12.65		
10260	3000	1766	6.09	1848	6.98	1927	7.87	2004	8.76	2082	9.68	2161	10.64	2240	11.59	2323	12.57	2400	13.65		
10944	3200	1840	6.87	1918	7.80	1995	8.72	2070	9.64	2140	10.60	2213	11.59	2291	12.59	2363	13.65	2437	14.71		
11628	3400	1914	7.76	1991	8.72	2063	9.71	2136	10.70	2205	11.70	2272	12.72	2343	13.75	2411	14.84	2481	15.94		
12312	3600	1988	8.72	2066	9.71	2136	10.77	2203	11.80	2272	12.86	2337	13.95	2405	15.01	2464	16.11				
12996	3800	2066	9.78	2139	10.84	2209	11.90	2274	13.03	2339	14.14	2404	15.22	2469	16.35	2525	17.51				
13680	4000	2155	10.98	2213	12.04	2285	13.17	2347	14.30	2408	15.42	2471	16.66	2535	17.78	2590	18.95				

All Capacities Based on Standard Air (Density .075#/cu.ft.—70°F—29.92" Hg. Bar.)

NOTES: (1) Ball bearings are standard on all Type NH, Class II-A Fans. (2) Values underlined indicate the most efficient point of operation for each pressure. (3) When equipped with Vortex Control increase speed 1%.

SIZE 40
DOUBLE WIDTH
DOUBLE INLET

CLARAGE TYPE NH FANS

CLASS II-A
MAX. RPM
2483

NON-OVERLOADING MEDIUM SPEED HIGH EFFICIENCY

Outlet Size 28 3/4" x 21 1/6" Outside

Wheel Diameter 20 in.

Inlet Size 24" Dia. Outside

Outlet Area 4.15 Sq. Ft. Inside

Tip Speed = RPM x 5.24

Max. BHP = 1.76 (RPM/1000)³

Volume of Air CFM	Outlet Velocity Feet per Minute	1/4" SP		3/8" SP		1/2" SP		5/8" SP		3/4" SP		7/8" SP		1" SP		1 1/4" SP		1 1/2" SP		1 3/4" SP	
		RPM	BHP	RPM	BHP	RPM	BHP	RPM	BHP	RPM	BHP	RPM	BHP	RPM	BHP	RPM	BHP	RPM	BHP	RPM	BHP
3320	800	488	.20	556	.32	623	.37	687	.46	745	.56	800	.67	853	.78	950	1.03	1038	1.29	1120	1.56
3735	900	518	.24	577	.33	638	.42	698	.51	755	.62	808	.73	858	.85	954	1.10	1041	1.37	1123	1.65
4150	1000	549	.29	604	.39	657	.48	712	.58	766	.68	818	.80	867	.93	959	1.19	1045	1.46	1126	1.75
4565	1100	583	.35	634	.45	682	.55	731	.65	781	.76	830	.88	878	1.01	968	1.28	1051	1.56	1130	1.86
4980	1200	617	.42	665	.52	710	.63	755	.74	800	.85	845	.97	890	1.10	978	1.38	1060	1.68	1136	1.98
5395	1300	651	.49	698	.60	741	.72	782	.83	823	.95	865	1.08	907	1.21	990	1.49	1070	1.80	1145	2.12
5810	1400	689	.57	732	.69	772	.82	812	.94	850	1.07	887	1.20	927	1.33	1004	1.61	1081	1.92	1155	2.26
6225	1500	727	.67	766	.79	805	.93	843	1.05	879	1.19	914	1.32	949	1.46	1022	1.76	1095	2.07	1167	2.40
6640	1600	766	.78	800	.90	839	1.05	875	1.17	910	1.32	944	1.47	976	1.61	1044	1.92	1112	2.23	1180	2.57
7055	1700	808	.90	838	1.04	873	1.17	908	1.32	941	1.47	974	1.62	1006	1.77	1068	2.08	1132	2.41	1196	2.75
7470	1800	850	1.04	876	1.18	907	1.32	942	1.48	974	1.63	1005	1.79	1036	1.95	1095	2.27	1154	2.61	1215	2.96
7885	1900	892	1.19	915	1.34	942	1.49	977	1.64	1008	1.81	1037	1.97	1067	2.14	1124	2.48	1179	2.83	1236	3.19
8300	2000			954	1.51	981	1.66	1012	1.83	1042	1.99	1070	2.17	1098	2.34	1154	2.70	1208	3.05	1260	3.43
8715	2100			995	1.70	1020	1.86	1047	2.03	1076	2.20	1104	2.38	1131	2.56	1185	2.94	1238	3.31	1287	3.69
9130	2200			1039	1.91	1059	2.07	1083	2.25	1110	2.42	1138	2.61	1166	2.80	1217	3.19	1268	3.57	1316	3.97
9545	2300					1098	2.30	1122	2.49	1145	2.66	1173	2.85	1200	3.04	1249	3.45	1298	3.86	1346	4.27
9960	2400					1139	2.56	1161	2.73	1183	2.92	1208	3.11	1234	3.32	1283	3.73	1329	4.15	1376	4.57
10375	2500					1182	2.82	1200	3.01	1221	3.21	1243	3.39	1268	3.60	1317	4.03	1362	4.46	1407	4.94
10790	2600							1239	3.31	1260	3.50	1281	3.69	1302	3.90	1351	4.34	1396	4.77	1439	5.27
11620	2800							1322	3.96	1337	4.15	1358	4.40	1378	4.61	1418	5.06	1464	5.52	1505	6.06
12450	3000							1405	4.69	1419	4.94	1435	5.19	1454	5.40	1489	5.85	1532	6.35	1572	6.85
13280	3200									1501	5.77	1517	6.02	1531	6.27	1567	6.76	1600	7.26	1640	7.76
14110	3400									1583	6.72	1599	6.97	1613	7.26	1645	7.76	1675	8.30	1708	8.84
14940	3600									1667	7.80	1681	8.05	1698	8.34	1723	8.88	1755	9.46	1781	10.00

Volume of Air CFM	Outlet Velocity Feet per Minute	2" SP		2 1/2" SP		3" SP		3 1/2" SP		4" SP		4 1/2" SP		5" SP		5 1/2" SP		6" SP		6 1/2" SP	
		RPM	BHP	RPM	BHP	RPM	BHP	RPM	BHP	RPM	BHP	RPM	BHP	RPM	BHP	RPM	BHP	RPM	BHP	RPM	BHP
4150	1000	1201	2.06	1338	2.70																
4565	1100	1205	2.17	1342	2.82																
4980	1200	1209	2.31	1346	2.96																
5395	1300	1216	2.45	1350	3.12	1473	3.91	1588	4.73	1694	5.60										
5810	1400	1225	2.61	1356	3.33	1478	4.10	1591	4.94	1697	5.81										
6225	1500	1236	2.77	1363	3.52	1483	4.31	1595	5.15	1701	6.02										
6640	1600	1247	2.93	1373	3.71	1490	4.52	1600	5.36	1705	6.27	1805	7.18	1899	8.22	1989	9.25	2075	10.33	2158	11.45
7055	1700	1259	3.12	1384	3.91	1499	4.73	1607	5.60	1710	6.52	1809	7.47	1903	8.51	1993	9.50	2079	10.58	2161	11.74
7470	1800	1275	3.32	1395	4.12	1509	5.02	1615	5.89	1717	6.81	1814	7.80	1907	8.84	1997	9.81	2083	10.91	2164	12.08
7885	1900	1294	3.56	1408	4.36	1520	5.23	1625	6.18	1725	7.12	1821	8.13	1912	9.12	2001	10.13	2087	11.25	2168	12.41
8300	2000	1315	3.81	1424	4.60	1532	5.48	1636	6.47	1734	7.43	1828	8.47	1918	9.50	2006	10.50	2091	11.66	2173	12.82
8715	2100	1338	4.08	1442	4.94	1545	5.77	1647	6.76	1745	7.74	1837	8.80	1926	9.88	2012	10.94	2096	12.08		
9130	2200	1363	4.36	1462	5.23	1561	6.10	1660	7.05	1756	8.06	1847	9.13	1935	10.27	2020	11.38	2102	12.53		
9545	2300	1392	4.69	1484	5.52	1580	6.43	1673	7.39	1768	8.40	1858	9.55	1946	10.67	2029	11.82	2110	12.99		
9960	2400	1421	5.02	1509	5.89	1600	6.81	1691	7.76	1780	8.80	1870	9.88	1956	11.07	2039	12.26	2119	13.45		
10375	2500	1451	5.35	1535	6.27	1622	7.22	1709	8.22	1795	9.21	1883	10.33	1968	11.47	2050	12.70	2129	13.91		
10790	2600	1482	5.73	1564	6.65	1645	7.64	1729	8.63	1813	9.63	1896	10.75	1980	11.91	2061	13.14	2140	14.40		
11620	2800	1544	6.52	1624	7.51	1700	8.55	1775	9.59	1853	10.67	1931	11.74	2009	12.91	2086	14.11	2163	15.36		
12450	3000	1610	7.39	1685	8.47	1758	9.55	1828	10.62	1899	11.74	1970	12.91	2044	14.07	2119	15.27	2189	16.56		
13280	3200	1678	8.34	1749	9.46	1820	10.58	1888	11.70	1952	12.87	2019	14.07	2090	15.27	2156	16.56	2223	17.84		
14110	3400	1748	9.42	1816	10.58	1882	11.79	1948	12.99	2011	14.19	2072	15.44	2137	16.68	2199	18.01	2264	19.34		
14940	3600	1812	10.58	1882	11.79	1948	13.07	2010	14.32	2073	15.60	2132	16.93	2194	18.22	2248	19.55				
15770	3800	1885	11.87	1952	13.16	2015	14.44	2074	15.81	2134	17.18	2193	18.47	2252	19.84	2304	21.25				
16600	4000	1966	13.32	2020	14.61	2084	15.98	2141	17.35	2197	18.72	2254	20.21	2313	21.58	2362	22.99				

All Capacities Based on Standard Air (Density .075#/cu.ft.—70°F—29.92" Hg. Bar.)

NOTES: (1) Ball bearings are standard on all Type NH, Class II-A Fans. (2) Values underlined indicate the most efficient point of operation for each pressure. (3) When equipped with Vortex Control increase speed 1%.

CLASS II-A
MAX. RPM
2232

CLARAGE TYPE NH FANS

NON-OVERLOADING MEDIUM SPEED HIGH EFFICIENCY

SIZE 44¹/₂
DOUBLE WIDTH
DOUBLE INLET

Outlet Size 31³/₄" x 23⁷/₁₆" Outside

Wheel Diameter 22¹/₄ in.

Inlet Size 27" Dia. Outside

Outlet Area 5.09 Sq. Ft. Inside

Tip Speed = RPM × 5.83

Max. BHP = 2.99 $\left(\frac{\text{RPM}}{1000}\right)^3$

Volume of Air CFM	Outlet Velocity Feet per Minute	1/4" SP		3/8" SP		1/2" SP		5/8" SP		3/4" SP		7/8" SP		1" SP		1 1/4" SP		1 1/2" SP		1 3/4" SP	
		RPM	BHP	RPM	BHP	RPM	BHP	RPM	BHP	RPM	BHP	RPM	BHP	RPM	BHP	RPM	BHP	RPM	BHP	RPM	BHP
4072	800	438	.25	500	.35	560	.45	618	.57	669	.69	719	.82	767	.96	854	1.26	933	1.59	1006	1.91
4581	900	466	.30	519	.40	573	.51	627	.63	678	.76	726	.90	772	1.05	857	1.35	936	1.67	1009	2.03
5090	1000	494	.36	543	.47	591	.59	640	.71	689	.84	735	.99	779	1.14	862	1.46	940	1.79	1012	2.15
5599	1100	524	.43	570	.55	613	.67	657	.80	702	.93	746	1.08	789	1.24	870	1.57	945	1.91	1016	2.29
6108	1200	554	.51	597	.64	638	.77	678	.91	719	1.05	759	1.19	800	1.35	879	1.69	952	2.06	1021	2.43
6617	1300	585	.60	627	.74	663	.88	703	1.02	739	1.17	777	1.32	815	1.48	890	1.83	962	2.21	1029	2.59
7126	1400	619	.70	657	.84	693	1.00	730	1.15	764	1.31	798	1.47	833	1.63	903	1.97	972	2.36	1038	2.77
7635	1500	654	.82	688	.97	723	1.14	757	1.30	790	1.46	820	1.62	853	1.80	919	2.15	984	2.53	1049	2.95
8144	1600	685	.96	719	1.11	754	1.28	786	1.45	818	1.62	848	1.80	878	1.98	938	2.35	1000	2.74	1060	3.16
8653	1700	725	1.11	752	1.27	785	1.44	816	1.62	846	1.81	876	1.99	904	2.18	960	2.56	1017	2.96	1075	3.37
9162	1800	765	1.28	786	1.45	816	1.62	847	1.81	875	2.00	904	2.20	931	2.43	984	2.79	1037	3.20	1092	3.63
9671	1900	805	1.46	822	1.64	847	1.82	877	2.02	905	2.22	932	2.41	959	2.64	1010	3.04	1060	3.47	1111	3.91
10180	2000			858	1.86	882	2.04	908	2.24	936	2.44	962	2.66	987	2.88	1038	3.31	1085	3.75	1132	4.21
10689	2100			895	2.09	917	2.29	939	2.48	967	2.70	992	2.92	1017	3.15	1065	3.60	1112	4.06	1157	4.53
11198	2200			933	2.34	952	2.54	974	2.75	998	2.94	1023	3.20	1048	3.43	1093	3.91	1139	4.38	1183	4.87
11707	2300					987	2.82	1009	3.05	1029	3.26	1054	3.49	1078	3.73	1122	4.23	1166	4.73	1210	5.23
12216	2400					1024	3.14	1044	3.35	1063	3.58	1086	3.82	1109	4.07	1152	4.58	1195	5.09	1237	5.60
12725	2500					1063	3.46	1079	3.70	1097	3.93	1118	4.16	1139	4.42	1183	4.94	1224	5.47	1265	6.06
13234	2600							1114	4.06	1133	4.29	1152	4.54	1170	4.79	1215	5.34	1254	5.85	1293	6.46
14252	2800							1188	4.85	1202	5.09	1222	5.40	1238	5.65	1275	6.21	1315	6.77	1352	7.43
15270	3000							1263	5.75	1277	6.06	1290	6.36	1306	6.62	1338	7.18	1377	7.79	1413	8.40
16288	3200									1352	7.08	1363	7.38	1376	7.69	1408	8.30	1437	8.91	1475	9.52
17306	3400									1427	8.25	1437	8.55	1450	8.91	1478	9.52	1508	10.18	1537	10.84
18324	3600									1502	9.57	1511	9.87	1526	10.23	1548	10.89	1579	11.61	1601	12.27

Volume of Air CFM	Outlet Velocity Feet per Minute	2" SP		2 1/2" SP		3" SP		3 1/2" SP		4" SP		4 1/2" SP		5" SP		5 1/2" SP		6" SP		6 1/2" SP	
		RPM	BHP	RPM	BHP	RPM	BHP	RPM	BHP	RPM	BHP	RPM	BHP	RPM	BHP	RPM	BHP	RPM	BHP	RPM	BHP
5090	1000	1079	2.53	1203	3.34																
5599	1100	1083	2.67	1206	3.48																
6108	1200	1087	2.84	1209	3.67																
6617	1300	1093	3.01	1213	3.86	1325	4.79	1427	5.80	1523	6.87										
7126	1400	1101	3.20	1218	4.08	1328	5.03	1430	6.06	1526	7.13										
7635	1500	1111	3.40	1225	4.32	1333	5.29	1434	6.32	1529	7.38										
8144	1600	1121	3.60	1234	4.56	1339	5.54	1438	6.57	1533	7.69	1622	8.81	1708	10.18	1788	11.35	1865	12.67	1939	14.05
8653	1700	1132	3.82	1244	4.80	1347	5.80	1444	6.87	1537	7.99	1626	9.16	1711	10.43	1791	11.66	1868	12.98	1942	14.40
9162	1800	1146	4.08	1254	5.05	1356	6.10	1452	7.22	1543	8.35	1631	9.57	1714	10.84	1795	12.06	1871	13.39	1945	14.81
9671	1900	1163	4.37	1266	5.34	1366	6.41	1461	7.58	1550	8.75	1637	9.98	1719	11.20	1799	12.42	1875	13.79	1949	15.22
10180	2000	1181	4.68	1280	5.65	1377	6.72	1471	7.93	1559	9.16	1643	10.38	1724	11.66	1803	12.88	1879	14.30	1953	15.73
10689	2100	1202	5.01	1296	6.02	1389	7.08	1481	8.28	1568	9.52	1651	10.79	1731	12.11	1808	13.44	1884	14.81		
11198	2200	1225	5.34	1314	6.39	1403	7.48	1492	8.66	1578	9.87	1661	11.20	1739	12.62	1815	14.00	1890	15.37		
11707	2300	1251	5.75	1334	6.78	1420	7.89	1504	9.06	1589	10.33	1671	11.71	1749	13.08	1824	14.51	1896	15.93		
12216	2400	1278	6.16	1356	7.23	1438	8.35	1520	9.52	1600	10.79	1681	12.11	1759	13.54	1833	15.02	1905	16.39		
12725	2500	1305	6.57	1380	7.68	1458	8.86	1536	10.08	1614	11.30	1692	12.67	1769	14.10	1843	15.58	1914	17.05		
13234	2600	1332	7.02	1405	8.14	1478	9.37	1554	10.59	1630	11.81	1704	13.18	1780	14.61	1853	16.08	1924	17.66		
14252	2800	1388	7.99	1460	9.21	1528	10.49	1595	11.76	1666	13.08	1736	14.40	1805	15.83	1875	17.31	1944	18.83		
15270	3000	1448	9.06	1515	10.38	1580	11.71	1643	13.03	1707	14.40	1773	15.83	1837	17.26	1905	18.73	1968	20.31		
16288	3200	1508	10.23	1572	11.61	1636	12.98	1697	14.35	1755	15.78	1814	17.26	1878	18.73	1938	20.31	1998	21.89		
17306	3400	1568	11.55	1632	12.98	1692	14.46	1751	15.93	1808	17.41	1863	18.93	1921	20.46	1976	22.09	2035	23.72		
18324	3600	1630	12.98	1694	14.46	1750	16.03	1806	17.56	1863	19.14	1916	20.77	1972	22.35	2020	23.97				
19342	3800	1694	14.56	1756	16.14	1811	17.71	1865	19.39	1918	21.07	1971	22.65	2024	24.33	2071	26.06				
20360	4000	1767	16.34	1818	17.92	1873	19.60	1925	21.28	1974	22.96	2026	24.79	2079	26.47	2123	28.20				

All Capacities Based on Standard Air (Density .075#/cu.ft.—70°F—29.92" Hg. Bar.)

NOTES: (1) Ball bearings are standard on all Type NH, Class II-A Fans. (2) Values underlined indicate the most efficient point of operation for each pressure. (3) When equipped with Vortex Control increase speed 1%.

SIZE 49
DOUBLE WIDTH
DOUBLE INLET

CLARAGE TYPE NH FANS

NON-OVERLOADING MEDIUM SPEED HIGH EFFICIENCY

CLASS II-A
MAX. RPM
2027

Outlet Size 35³/₈" x 25¹/₁₆" Outside

Wheel Diameter 24¹/₂ in.

Inlet Size 29" Dia. Outside

Outlet Area 6.22 Sq. Ft. Inside

Tip Speed = RPM x 6.41

Max. BHP = 4.90 $\left(\frac{\text{RPM}}{1000}\right)^3$

Volume of Air CFM	Outlet Velocity Feet per Minute	1/4" SP		3/8" SP		1/2" SP		5/8" SP		3/4" SP		7/8" SP		1" SP		1 1/4" SP		1 1/2" SP		1 3/4" SP	
		RPM	BHP	RPM	BHP	RPM	BHP	RPM	BHP	RPM	BHP	RPM	BHP	RPM	BHP	RPM	BHP	RPM	BHP	RPM	BHP
4976	800	396	.30	452	.41	508	.54	561	.68	609	.83	654	.99	697	1.15	776	1.51	848	1.90	915	2.29
5598	900	420	.36	469	.49	519	.61	569	.75	616	.92	660	1.08	702	1.26	780	1.61	851	2.00	917	2.43
6220	1000	444	.43	490	.57	534	.70	580	.85	624	1.01	668	1.18	708	1.37	784	1.75	855	2.14	920	2.57
6842	1100	472	.52	513	.66	554	.81	594	.96	636	1.12	676	1.29	716	1.49	790	1.89	859	2.30	924	2.74
7464	1200	500	.61	538	.76	576	.92	613	1.08	650	1.26	688	1.43	726	1.62	798	2.03	865	2.47	929	2.92
8086	1300	528	.72	565	.88	600	1.05	635	1.22	668	1.40	703	1.59	738	1.78	807	2.19	873	2.64	935	3.12
8708	1400	557	.85	592	1.01	625	1.20	658	1.37	690	1.57	721	1.76	754	1.95	818	2.36	882	2.83	943	3.32
9330	1500	589	.99	620	1.17	652	1.36	682	1.55	713	1.75	742	1.95	772	2.15	831	2.58	892	3.04	951	3.53
9952	1600	621	1.16	648	1.33	679	1.54	708	1.73	737	1.94	766	2.16	793	2.37	849	2.82	905	3.28	961	3.78
10574	1700	653	1.33	679	1.52	706	1.73	735	1.94	762	2.16	790	2.39	816	2.61	867	3.07	920	3.55	974	4.04
11196	1800	686	1.54	710	1.74	734	1.94	763	2.17	789	2.40	813	2.63	840	2.87	889	3.34	938	3.84	988	4.35
11818	1900	720	1.75	741	1.97	763	2.18	791	2.42	816	2.66	839	2.89	864	3.15	912	3.65	958	4.15	1005	4.67
12440	2000			772	2.23	794	2.45	819	2.68	843	2.93	866	3.18	889	3.45	936	3.97	980	4.50	1024	5.04
13062	2100			806	2.50	825	2.74	847	2.97	870	3.23	894	3.50	916	3.77	960	4.32	1003	4.86	1045	5.43
13684	2200			841	2.81	857	3.05	878	3.29	898	3.56	922	3.83	943	4.11	985	4.68	1027	5.26	1068	5.83
14306	2300					889	3.39	909	3.66	927	3.91	949	4.19	970	4.47	1011	5.07	1051	5.68	1091	6.27
14928	2400					922	3.76	940	4.02	957	4.30	977	4.57	998	4.87	1038	5.48	1076	6.10	1115	6.72
15550	2500					957	4.15	971	4.43	988	4.72	1006	4.99	1026	5.30	1066	5.93	1102	6.56	1139	7.21
16172	2600							1004	4.86	1020	5.14	1038	5.44	1054	5.75	1094	6.41	1130	7.03	1164	7.71
17416	2800							1071	5.82	1083	6.13	1100	6.47	1115	6.78	1148	7.40	1185	8.15	1218	8.89
18660	3000							1138	6.90	1150	7.22	1162	7.59	1177	7.96	1205	8.65	1240	9.33	1273	10.08
19904	3200									1218	8.52	1228	8.83	1239	9.21	1268	9.95	1295	10.64	1328	11.44
21148	3400									1281	9.89	1294	10.26	1306	10.64	1331	11.44	1356	12.19	1383	13.00
22392	3600									1350	11.51	1360	11.88	1375	12.25	1394	13.06	1421	13.87	1441	14.74

Volume of Air CFM	Outlet Velocity Feet per Minute	2" SP		2 1/2" SP		3" SP		3 1/2" SP		4" SP		4 1/2" SP		5" SP		5 1/2" SP		6" SP		6 1/2" SP	
		RPM	BHP	RPM	BHP	RPM	BHP	RPM	BHP	RPM	BHP	RPM	BHP	RPM	BHP	RPM	BHP	RPM	BHP	RPM	BHP
6220	1000	982	3.02	1094	4.02																
6842	1100	985	3.19	1097	4.19																
7464	1200	989	3.40	1100	4.40																
8086	1300	994	3.60	1104	4.63	1205	5.74	1298	6.97	1385	8.21										
8708	1400	1000	3.84	1108	4.90	1208	6.04	1301	7.28	1388	8.52										
9330	1500	1008	4.07	1114	5.18	1212	6.35	1304	7.59	1391	8.83										
9952	1600	1017	4.31	1121	5.46	1217	6.66	1308	7.90	1394	9.20	1476	10.57	1553	12.00	1626	13.56	1696	15.18	1764	16.79
10574	1700	1026	4.58	1129	5.74	1224	6.97	1313	8.21	1398	9.58	1479	11.01	1556	12.44	1629	13.93	1699	15.55	1767	17.23
11196	1800	1039	4.88	1138	6.05	1232	7.28	1319	8.63	1403	10.01	1483	11.45	1559	12.93	1632	14.37	1702	16.05	1770	17.73
11818	1900	1053	5.24	1147	6.41	1240	7.66	1327	9.07	1409	10.45	1488	11.94	1563	13.43	1636	14.94	1705	16.55	1773	18.20
12440	2000	1069	5.61	1160	6.79	1249	8.09	1335	9.51	1416	10.94	1494	12.44	1568	13.99	1640	15.56	1709	17.17	1776	18.78
13062	2100	1087	6.01	1173	7.22	1259	8.52	1344	9.95	1424	11.44	1500	12.94	1574	14.55	1645	16.18	1713	17.79		
13684	2200	1107	6.41	1189	7.65	1271	8.96	1353	10.39	1432	11.94	1508	13.44	1580	15.11	1650	16.80	1718	18.41		
14306	2300	1130	6.84	1206	8.08	1285	9.45	1363	10.83	1441	12.44	1516	14.00	1588	15.67	1657	17.42	1724	19.03		
14928	2400	1153	7.34	1226	8.64	1301	10.01	1376	11.44	1451	12.94	1525	14.56	1596	16.23	1665	18.04	1731	19.66		
15550	2500	1176	7.90	1247	9.20	1318	10.57	1390	12.07	1463	13.50	1534	15.18	1605	16.79	1673	18.66	1738	20.40		
16172	2600	1201	8.46	1270	9.77	1337	11.26	1406	12.70	1476	14.18	1545	15.80	1615	17.54	1681	19.28	1746	21.21		
17416	2800	1250	9.58	1317	11.07	1380	12.56	1442	14.06	1507	15.67	1571	17.23	1630	18.97	1700	20.77	1764	22.58		
18660	3000	1304	10.82	1365	12.44	1426	14.05	1485	15.61	1543	17.23	1604	18.97	1663	20.71	1725	22.45	1784	24.38		
19904	3200	1355	12.25	1416	13.93	1474	15.55	1531	17.17	1587	18.91	1641	20.71	1697	22.45	1753	24.38	1810	26.19		
21148	3400	1414	13.81	1470	15.55	1524	17.29	1579	19.10	1632	20.90	1683	22.70	1735	24.57	1787	26.44	1841	28.43		
22392	3600	1469	15.55	1525	17.29	1576	19.22	1627	21.09	1680	22.95	1730	24.88	1778	26.75	1826	28.74				
23636	3800	1526	17.48	1580	19.34	1631	21.27	1679	23.20	1729	25.25	1777	27.18	1824	29.17	1870	31.22				
24880	4000	1591	19.59	1635	21.46	1686	23.51	1733	25.50	1778	27.55	1825	29.73	1872	31.72	1916	33.84				

All Capacities Based on Standard Air (Density .075#/cu.ft.—70°—29.92" Hg. Bar.)

NOTES: (1) Ball bearings are standard on all Type NH, Class II-A Fans. (2) Values underlined indicate the most efficient point of operation for each pressure. (3) When equipped with Vortex Control increase speed 1%.

**CLASS II-A
MAX. RPM
1840**

CLARAGE TYPE NH FANS

NON-OVERLOADING MEDIUM SPEED HIGH EFFICIENCY

**SIZE 54
DOUBLE WIDTH
DOUBLE INLET**

Outlet Size 39" x 28 5/16" Outside

Wheel Diameter 27 in.

Inlet Size 32" Dia. Outside

Outlet Area 7.56 Sq. Ft. Inside

Tip Speed = RPM x 7.07

Max. BHP = 7.96 $\left(\frac{\text{RPM}}{1000}\right)^3$

Volume of Air CFM	Outlet Velocity Feet per Minute	1/4" SP		3/8" SP		1/2" SP		5/8" SP		3/4" SP		7/8" SP		1" SP		1 1/4" SP		1 1/2" SP		1 3/4" SP	
		RPM	BHP	RPM	BHP	RPM	BHP	RPM	BHP	RPM	BHP	RPM	BHP	RPM	BHP	RPM	BHP	RPM	BHP	RPM	BHP
6048	800	359	.36	410	.50	461	.66	508	.83	552	1.01	593	1.20	632	1.40	704	1.83	769	2.31	829	2.78
6804	900	381	.44	425	.59	471	.74	516	.91	558	1.12	598	1.32	636	1.53	707	1.96	772	2.43	831	2.95
7560	1000	403	.52	444	.69	485	.85	526	1.04	566	1.22	605	1.44	642	1.66	711	2.12	775	2.60	834	3.12
8316	1100	428	.63	466	.80	502	.98	539	1.16	576	1.36	613	1.57	649	1.81	717	2.31	779	2.79	838	3.33
9072	1200	453	.74	488	.92	523	1.12	556	1.32	590	1.53	624	1.74	658	1.97	724	2.46	785	3.00	842	3.55
9828	1300	478	.87	512	1.07	544	1.28	576	1.49	606	1.70	637	1.93	669	2.16	732	2.66	792	3.21	848	3.80
10584	1400	505	1.03	537	1.23	567	1.46	597	1.67	625	1.91	654	2.14	683	2.37	742	2.87	800	3.44	855	4.04
11340	1500	534	1.20	562	1.42	591	1.65	619	1.89	646	2.13	673	2.37	700	2.62	754	3.14	809	3.70	863	4.29
12096	1600	563	1.41	587	1.62	616	1.87	642	2.09	668	2.36	694	2.62	719	2.88	769	3.42	821	3.98	871	4.60
12852	1700	592	1.62	615	1.85	641	2.09	666	2.36	691	2.63	715	2.90	740	3.18	786	3.73	835	4.31	883	4.91
13608	1800	622	1.87	643	2.12	666	2.36	691	2.64	715	2.92	737	3.20	761	3.49	806	4.06	850	4.66	896	5.29
14364	1900	653	2.13	671	2.39	692	2.65	716	2.94	739	3.23	761	3.52	783	3.83	827	4.44	869	5.05	911	5.70
15120	2000			700	2.71	721	2.98	741	3.26	764	3.56	785	3.87	806	4.19	848	4.83	889	5.47	928	6.13
15876	2100			731	3.04	750	3.33	767	3.61	790	3.93	810	4.25	830	4.58	870	5.25	910	5.91	947	6.60
16632	2200			762	3.41	779	3.70	795	4.01	816	4.32	835	4.66	855	5.00	893	5.69	931	6.39	968	7.08
17388	2300					808	4.12	823	4.45	842	4.75	861	5.09	880	5.44	917	6.19	953	6.89	989	7.64
18144	2400					838	4.57	851	4.89	868	5.22	887	5.56	905	5.92	941	6.66	976	7.42	1011	8.16
18900	2500					868	5.04	880	5.38	896	5.74	913	6.07	930	6.44	966	7.20	1000	7.98	1033	8.77
19656	2600							909	5.91	925	6.25	940	6.62	955	6.99	992	7.79	1024	8.54	1056	9.37
21168	2800							972	7.07	982	7.45	997	7.86	1011	8.24	1041	9.00	1074	9.90	1104	10.81
22680	3000							1031	8.39	1043	8.77	1053	9.22	1067	9.68	1092	10.51	1124	11.34	1154	12.25
24192	3200									1105	10.36	1113	10.74	1124	11.19	1151	12.10	1174	12.93	1204	13.91
25704	3400									1162	12.02	1173	12.47	1184	12.93	1207	13.91	1230	14.82	1253	15.80
27216	3600									1224	13.99	1233	14.44	1246	14.89	1263	15.88	1288	16.86	1307	17.92

Volume of Air CFM	Outlet Velocity Feet per Minute	2" SP		2 1/2" SP		3" SP		3 1/2" SP		4" SP		4 1/2" SP		5" SP		5 1/2" SP		6" SP		6 1/2" SP	
		RPM	BHP	RPM	BHP	RPM	BHP	RPM	BHP	RPM	BHP	RPM	BHP	RPM	BHP	RPM	BHP	RPM	BHP	RPM	BHP
7560	1000	890	3.67	992	4.89																
8316	1100	893	3.88	994	5.10																
9072	1200	896	4.13	997	5.34																
9828	1300	901	4.38	1001	5.62	1092	6.98	1177	8.47	1255	9.98										
10584	1400	907	4.66	1005	5.94	1095	7.33	1179	8.84	1258	10.36										
11340	1500	914	4.94	1010	6.29	1099	7.71	1182	9.22	1261	10.74										
12096	1600	922	5.24	1016	6.64	1104	8.09	1186	9.60	1264	11.19	1338	12.85	1408	14.59	1474	16.48	1538	18.45	1599	20.41
12852	1700	930	5.56	1024	6.99	1110	8.47	1191	10.00	1268	11.64	1341	13.38	1411	15.12	1477	16.93	1541	18.90	1601	20.94
13608	1800	942	5.93	1032	7.36	1117	8.85	1196	10.50	1272	12.17	1344	13.91	1414	15.72	1480	17.48	1544	19.50	1604	21.55
14364	1900	954	6.37	1040	7.79	1124	9.30	1203	11.03	1278	12.70	1349	14.51	1417	16.33	1483	18.14	1547	20.11	1607	22.18
15120	2000	969	6.82	1051	8.24	1132	9.83	1210	11.56	1284	13.30	1354	15.11	1422	17.01	1487	18.89	1550	20.86	1610	22.83
15876	2100	986	7.30	1064	8.77	1141	10.36	1218	12.09	1291	13.91	1360	15.72	1427	17.69	1491	19.64	1553	21.62		
16632	2200	1004	7.79	1078	9.30	1153	10.89	1226	12.62	1299	14.50	1367	16.33	1433	18.37	1496	20.40	1558	22.38		
17388	2300	1024	8.31	1094	9.90	1165	11.49	1236	13.15	1307	15.11	1375	17.01	1440	19.05	1502	21.16	1563	23.14		
18144	2400	1045	8.92	1111	10.51	1179	12.17	1248	13.91	1315	15.72	1383	17.69	1447	19.73	1509	21.92	1569	23.90		
18900	2500	1067	9.60	1130	11.19	1195	12.85	1261	14.67	1326	16.42	1391	18.44	1455	20.41	1516	22.68	1576	24.80		
19656	2600	1089	10.28	1151	11.87	1212	13.68	1275	15.42	1338	17.23	1401	19.20	1464	21.32	1524	23.44	1583	25.78		
21168	2800	1133	11.64	1194	13.46	1251	15.27	1308	17.09	1366	19.05	1425	20.94	1483	23.06	1541	25.25	1600	27.44		
22680	3000	1182	13.15	1237	15.12	1293	17.09	1346	18.98	1399	20.94	1454	23.06	1507	25.17	1564	27.29	1617	29.64		
24192	3200	1232	14.89	1284	16.93	1337	18.90	1388	20.87	1438	22.98	1487	25.17	1539	27.29	1590	29.64	1641	31.83		
25704	3400	1282	16.78	1333	18.90	1381	21.02	1431	23.21	1479	25.40	1526	27.59	1573	29.86	1620	32.13	1669	34.55		
27216	3600	1332	18.90	1383	21.02	1429	23.36	1475	25.63	1523	27.90	1568	30.24	1612	32.51	1655	34.93				
28728	3800	1383	21.24	1433	23.51	1479	25.86	1522	28.20	1566	30.69	1611	33.04	1654	35.46	1695	37.95				
30240	4000	1443	23.81	1483	26.08	1529	28.58	1571	31.00	1612	33.49	1655	36.14	1697	38.56	1737	41.13				

All Capacities Based on Standard Air (Density .075#/cu.ft.—70°—29.92" Hg. Bar.)

NOTES: (1) Ball bearings are standard on all Type NH, Class II-A Fans. (2) Values underlined indicate the most efficient point of operation for each pressure. (3) When equipped with Vortex Control increase speed 1%.

SIZE 60
DOUBLE WIDTH
DOUBLE INLET

CLARAGE TYPE NH FANS

CLASS II-A
MAX. RPM
1655

NON-OVERLOADING MEDIUM SPEED HIGH EFFICIENCY

Outlet Size 43" x 31 1/8" Outside

Wheel Diameter 30 in.

Inlet Size 35" Dia. Outside

Outlet Area 9.27 Sq. Ft. Inside

Tip Speed = RPM x 7.85

Max. BHP = 13.49 $\left(\frac{\text{RPM}}{1000}\right)^3$

Volume of Air CFM	Outlet Velocity Feet per Minute	1/4" SP		3/8" SP		1/2" SP		5/8" SP		3/4" SP		7/8" SP		1" SP		1 1/4" SP		1 1/2" SP		1 3/4" SP	
		RPM	BHP	RPM	BHP	RPM	BHP	RPM	BHP	RPM	BHP	RPM	BHP	RPM	BHP	RPM	BHP	RPM	BHP	RPM	BHP
7416	800	324	.44	369	.61	415	.81	458	1.02	497	1.24	534	1.47	569	1.71	634	2.24	693	2.84	747	3.41
8343	900	343	.54	383	.72	424	.91	465	1.12	503	1.37	539	1.61	573	1.87	637	2.40	695	2.98	749	3.62
9270	1000	363	.64	400	.84	436	1.05	473	1.27	510	1.50	545	1.77	578	2.04	640	2.60	698	3.19	751	3.83
10197	1100	385	.77	419	.98	452	1.21	485	1.43	519	1.67	552	1.93	585	2.22	645	2.82	702	3.42	754	4.08
11124	1200	408	.91	439	1.13	471	1.37	500	1.61	531	1.87	562	2.13	592	2.41	652	3.04	707	3.68	758	4.35
12051	1300	431	1.07	461	1.32	490	1.57	518	1.83	546	2.09	574	2.36	603	2.65	659	3.26	713	3.94	763	4.65
12978	1400	455	1.26	484	1.51	511	1.79	538	2.14	563	2.34	589	2.62	615	2.91	668	3.52	720	4.22	770	4.95
13905	1500	481	1.47	507	1.74	533	2.02	558	2.32	582	2.61	606	2.90	630	3.21	679	3.85	728	4.53	777	5.27
14832	1600	507	1.72	530	1.98	555	2.29	578	2.57	602	2.89	625	3.22	647	3.53	693	4.20	739	4.89	785	5.64
15759	1700	533	1.98	554	2.27	577	2.57	600	2.89	622	3.23	645	3.56	664	3.89	708	4.57	752	5.28	795	6.03
16686	1800	560	2.29	579	2.60	599	2.89	623	3.24	644	3.58	665	3.92	685	4.27	726	4.98	766	5.72	807	6.49
17613	1900	588	2.61	605	2.93	624	3.25	646	3.61	666	3.96	685	4.31	706	4.69	745	5.44	782	6.19	821	6.99
18540	2000			631	3.32	649	3.65	669	4.00	688	4.37	707	4.75	727	5.14	764	5.92	801	6.70	836	7.52
19467	2100			658	3.73	674	4.08	692	4.43	711	4.82	730	5.21	748	5.62	784	6.44	820	7.25	853	8.09
20394	2200			686	4.18	700	4.54	716	4.91	734	5.30	753	5.71	770	6.13	804	6.98	839	7.83	872	8.69
21321	2300					726	5.05	742	5.45	757	5.82	776	6.24	793	6.67	825	7.56	858	8.45	891	9.35
22248	2400					753	5.60	768	6.00	782	6.41	799	6.81	816	7.26	847	8.17	879	9.09	911	10.01
23175	2500					782	6.18	794	6.60	807	7.04	822	7.44	839	7.90	870	8.83	900	9.78	931	10.75
24102	2600							820	7.25	833	7.67	847	8.11	861	8.57	893	9.55	923	10.50	951	11.49
25956	2800							874	8.67	883	9.13	898	9.64	911	10.10	937	11.03	968	12.12	994	13.26
27810	3000							929	10.29	937	10.75	949	11.31	961	11.87	984	12.89	1013	13.91	1039	15.02
29664	3200									992	12.69	1003	13.16	1012	13.72	1035	14.83	1058	15.85	1085	17.06
31518	3400									1047	14.74	1057	15.30	1066	15.85	1086	17.06	1107	18.17	1130	19.37
33372	3600									1102	17.15	1111	17.71	1122	18.26	1137	19.47	1160	20.67	1177	21.97

Volume of Air CFM	Outlet Velocity Feet per Minute	2" SP		2 1/2" SP		3" SP		3 1/2" SP		4" SP		4 1/2" SP		5" SP		5 1/2" SP		6" SP		6 1/2" SP	
		RPM	BHP	RPM	BHP	RPM	BHP	RPM	BHP	RPM	BHP	RPM	BHP	RPM	BHP	RPM	BHP	RPM	BHP	RPM	BHP
9270	1000	802	4.51	893	6.00																
10197	1100	804	4.76	895	6.25																
11124	1200	807	5.06	898	6.55																
12051	1300	811	5.37	901	6.90	984	8.56	1060	10.39	1131	12.24										
12978	1400	817	5.71	905	7.29	986	8.97	1062	10.85	1133	12.70										
13905	1500	823	6.06	909	7.71	990	9.44	1065	11.31	1136	13.16										
14832	1600	830	6.42	915	8.13	994	9.91	1068	11.77	1139	13.72	1205	15.76	1268	17.89	1327	20.21	1385	22.62	1441	25.03
15759	1700	838	6.82	922	8.56	999	10.38	1072	12.23	1142	14.28	1208	16.39	1270	18.54	1329	20.76	1387	23.18	1443	25.68
16686	1800	848	7.28	929	9.02	1005	10.85	1077	12.88	1146	14.92	1211	17.06	1273	19.28	1332	21.41	1390	23.92	1445	26.42
17613	1900	860	7.81	937	9.55	1012	11.40	1083	13.53	1151	15.57	1215	17.80	1276	20.03	1335	22.26	1393	24.67	1447	27.16
18540	2000	873	8.36	947	10.10	1020	12.05	1090	14.18	1156	16.31	1220	18.54	1280	20.85	1339	23.18	1396	25.59	1450	28.00
19467	2100	888	8.95	958	10.75	1028	12.70	1097	14.83	1163	17.05	1225	19.28	1285	21.69	1343	24.10	1399	26.51		
20394	2200	904	9.55	971	11.40	1038	13.35	1105	15.48	1170	17.79	1231	20.02	1290	22.53	1348	25.02	1403	27.43		
21321	2300	923	10.19	985	12.05	1049	14.09	1113	16.13	1177	18.53	1238	20.86	1297	23.37	1353	25.95	1408	28.36		
22248	2400	941	10.94	1001	12.88	1062	14.92	1124	17.06	1185	19.28	1245	21.69	1304	24.21	1359	26.88	1413	29.29		
23175	2500	961	11.77	1018	13.72	1076	15.76	1135	17.98	1194	20.12	1253	22.62	1311	25.05	1366	27.81	1419	30.41		
24102	2600	981	12.61	1037	14.55	1092	16.78	1148	18.91	1205	21.14	1262	23.55	1318	26.14	1375	28.74	1426	31.61		
25956	2800	1021	14.28	1075	16.50	1127	18.73	1178	20.95	1230	23.36	1283	25.68	1336	28.27	1389	30.96	1440	33.65		
27810	3000	1065	16.13	1114	18.54	1164	20.95	1212	23.27	1260	25.68	1310	28.27	1358	30.87	1409	33.46	1456	36.34		
29664	3200	1109	18.26	1156	20.76	1204	23.18	1250	25.59	1296	28.18	1340	30.87	1386	33.46	1432	36.34	1478	39.03		
31518	3400	1154	20.60	1200	23.18	1244	25.77	1289	28.46	1332	31.15	1375	33.84	1417	36.62	1460	39.40	1503	42.36		
33372	3600	1199	23.18	1245	25.77	1287	28.64	1329	31.43	1371	34.21	1413	37.08	1452	39.86	1490	42.83				
38226	3800	1246	26.05	1290	28.83	1332	31.70	1371	34.58	1411	37.64	1451	40.51	1489	43.48	1527	46.54				
37080	4000	1299	29.20	1335	31.98	1377	35.04	1415	38.01	1452	41.07	1490	44.31	1529	47.28	1564	50.43				

All Capacities Based on Standard Air (Density .075#/cu.ft.—70°—29.92" Hg. Bar.)

NOTES: (1) Ball bearings are standard on all Type NH, Class II-A Fans. (2) Values underlined indicate the most efficient point of operation for each pressure. (3) When equipped with Vortex Control increase speed 1%.

**CLASS II-A
MAX. RPM
1505**

CLARAGE TYPE NH FANS

NON-OVERLOADING MEDIUM SPEED HIGH EFFICIENCY

**SIZE 66
DOUBLE WIDTH
DOUBLE INLET**

Outlet Size 47½" x 34⅞" Outside

Wheel Diameter 33 in.

Inlet Size 38" Dia. Outside

Outlet Area 11.28 Sq. Ft. Inside

Tip Speed = RPM × 8.64

Max. BHP = 21.72 $\left(\frac{\text{RPM}}{1000}\right)^3$

Volume of Air CFM	Outlet Velocity Feet per Minute	¼" SP		⅜" SP		½" SP		⅝" SP		¾" SP		1" SP		1¼" SP		1½" SP		1¾" SP			
		RPM	BHP	RPM	BHP	RPM	BHP	RPM	BHP	RPM	BHP	RPM	BHP	RPM	BHP	RPM	BHP	RPM	BHP		
9024	800	294	.54	336	.74	377	.98	416	1.24	452	1.51	485	1.79	517	2.09	576	2.73	629	3.45	678	4.15
10150	900	311	.65	348	.88	385	1.11	422	1.36	457	1.67	490	1.96	520	2.28	578	2.92	631	3.63	681	4.40
11280	1000	330	.78	364	1.03	397	1.27	430	1.55	463	1.83	495	2.15	525	2.48	582	3.18	634	3.88	683	4.66
12408	1100	350	.94	381	1.20	411	1.47	441	1.74	472	2.03	502	2.35	531	2.70	586	3.44	637	4.16	685	4.96
13536	1200	370	1.11	399	1.38	428	1.67	455	1.96	483	2.28	510	2.59	538	2.93	592	3.69	642	4.48	689	5.29
14664	1300	391	1.30	419	1.60	445	1.91	471	2.22	496	2.54	522	2.88	548	3.23	599	3.97	648	4.79	694	5.66
15792	1400	414	1.53	439	1.84	464	2.18	488	2.49	512	2.84	535	3.19	559	3.54	607	4.29	654	5.13	699	6.03
16920	1500	437	1.79	460	2.12	484	2.46	506	2.81	529	3.18	551	3.53	572	3.90	617	4.68	662	5.52	706	6.41
18048	1600	460	2.10	481	2.41	504	2.79	525	3.13	547	3.52	568	3.91	588	4.30	630	5.11	672	5.94	713	6.86
19176	1700	485	2.41	504	2.76	524	3.12	545	3.52	566	3.93	586	4.33	605	4.74	643	5.56	683	6.43	722	7.33
20304	1800	510	2.79	527	3.16	544	3.52	566	3.94	586	4.35	604	4.77	623	5.20	660	6.06	696	6.96	733	7.90
21432	1900	535	3.18	550	3.56	567	3.96	587	4.39	606	4.82	623	5.25	641	5.71	677	6.62	711	7.54	746	8.51
22560	2000			573	4.04	590	4.44	608	4.86	626	5.31	643	5.78	661	6.25	694	7.21	727	8.16	759	9.15
23688	2100			598	4.53	613	4.96	629	5.39	646	5.87	663	6.34	681	6.84	712	7.84	744	8.82	775	9.85
24816	2200			624	5.09	636	5.53	651	5.98	666	6.45	684	6.95	701	7.46	731	8.49	762	9.53	792	10.57
25944	2300					659	6.15	674	6.63	688	7.08	705	7.59	721	8.11	750	9.19	780	10.29	809	11.38
27072	2400					684	6.81	697	7.30	710	7.79	726	8.29	741	8.83	770	9.94	798	11.07	827	12.18
28200	2500					710	7.52	720	8.03	733	8.56	747	9.06	761	9.61	790	10.75	818	11.90	845	13.08
29238	2600							744	8.82	757	9.33	770	9.87	781	10.42	811	11.62	838	12.75	864	13.99
31584	2800							794	10.55	805	11.11	816	11.73	827	12.30	852	13.42	879	14.78	903	16.13
33840	3000							844	12.52	854	13.08	862	13.76	874	14.44	894	15.68	920	16.92	944	18.27
36096	3200									903	15.45	911	16.02	921	16.69	941	18.05	961	19.29	985	20.76
38352	3400									952	17.94	960	18.61	969	19.29	988	20.76	1006	22.11	1026	23.58
40608	3600									1002	20.87	1009	21.54	1020	22.22	1035	23.69	1054	25.15	1069	26.73

Volume of Air CFM	Outlet Velocity Feet per Minute	2" SP		2½" SP		3" SP		3½" SP		4" SP		4½" SP		5" SP		5½" SP		6" SP		6½" SP	
		RPM	BHP	RPM	BHP	RPM	BHP	RPM	BHP	RPM	BHP	RPM	BHP	RPM	BHP	RPM	BHP	RPM	BHP	RPM	BHP
11280	1000	728	5.48	812	7.30																
12408	1100	730	5.79	814	7.60																
13536	1200	733	6.16	816	7.97																
14664	1300	737	6.53	819	8.39	894	10.41	963	12.63	1028	14.89										
15792	1400	742	6.96	822	8.87	896	10.94	965	13.19	1030	15.45										
16920	1500	748	7.39	826	9.37	899	11.50	967	13.76	1032	16.02										
18048	1600	754	7.82	832	9.92	903	12.06	970	14.33	1034	16.69	1095	19.18	1152	21.77	1206	24.59	1258	27.52	1309	30.46
19176	1700	761	8.30	838	10.41	908	12.62	974	14.90	1037	17.37	1097	19.97	1154	22.56	1208	25.27	1260	28.20	1310	31.25
20304	1800	770	8.85	844	10.98	914	13.19	979	15.68	1041	18.16	1100	20.77	1157	23.46	1211	26.06	1263	29.10	1312	32.15
21432	1900	781	9.50	851	11.62	920	13.87	984	16.47	1046	18.95	1104	21.66	1160	24.37	1214	27.07	1266	30.00	1314	33.05
22560	2000	793	10.17	860	12.30	927	14.66	990	17.26	1051	19.86	1108	22.56	1163	25.39	1217	28.20	1269	31.13	1318	34.07
23688	2100	807	10.90	870	13.08	934	15.45	997	18.05	1056	20.76	1113	23.46	1168	26.41	1220	29.33	1272	32.26		
24816	2200	822	11.63	882	13.87	943	16.24	1004	18.84	1063	21.66	1119	24.36	1173	27.42	1224	30.46	1275	33.39		
25944	2300	838	12.40	895	14.66	953	17.15	1011	19.63	1069	22.56	1125	25.38	1178	28.43	1229	31.58	1279	34.52		
27072	2400	855	13.31	909	15.67	965	18.16	1021	20.76	1076	23.46	1131	26.40	1184	29.44	1235	32.71	1284	35.64		
28200	2500	873	14.33	925	16.69	978	19.18	1032	21.89	1085	24.48	1138	27.52	1191	30.46	1241	33.84	1289	37.00		
29238	2600	891	15.35	942	17.71	992	20.42	1043	23.02	1095	25.72	1146	28.65	1198	31.81	1248	34.97	1295	38.46		
31584	2800	927	17.37	977	20.08	1024	22.79	1070	25.49	1118	28.43	1162	31.25	1214	34.40	1262	37.67	1308	40.95		
33840	3000	967	19.63	1012	22.56	1058	25.49	1101	28.31	1145	31.25	1190	34.40	1234	37.56	1280	40.72	1323	44.22		
36096	3200	1008	22.22	1050	25.27	1094	28.20	1136	31.13	1177	34.29	1218	37.56	1259	40.72	1301	44.22	1343	47.49		
38352	3400	1049	25.04	1090	28.20	1130	31.36	1171	34.63	1211	37.90	1249	41.17	1287	44.56	1326	47.94	1366	51.55		
40608	3600	1090	28.20	1131	31.36	1169	34.86	1207	38.24	1247	41.62	1284	45.12	1319	48.50	1354	52.11				
42864	3800	1132	31.70	1172	35.08	1210	38.58	1245	42.07	1283	45.80	1319	49.29	1354	52.90	1388	56.63				
45120	4000	1181	35.53	1213	38.92	1251	42.64	1286	46.25	1319	49.97	1354	53.92	1389	57.53	1422	61.36				

All Capacities Based on Standard Air (Density .075#/cu.ft.—70°—29.92" Hg. Bar.)

NOTES: (1) Ball bearings are standard on all Type NH, Class II-A Fans. (2) Values underlined indicate the most efficient point of operation for each pressure. (3) When equipped with Vortex Control increase speed 1%.

SIZE 73
DOUBLE WIDTH
DOUBLE INLET

CLARAGE TYPE NH FANS

CLASS II-A
MAX. RPM
1360

NON-OVERLOADING MEDIUM SPEED HIGH EFFICIENCY

Outlet Size 52 1/2" x 38 3/16" Outside

Wheel Diameter 36 1/2 in.

Inlet Size 42" Dia. Outside

Outlet Area 13.78 Sq. Ft. Inside

Tip Speed = RPM x 9.56

Max. BHP = 36.61 (RPM/1000)³

Volume of Air CFM	Outlet Velocity Feet per Minute	1/4" SP		3/8" SP		1/2" SP		5/8" SP		3/4" SP		7/8" SP		1" SP		1 1/4" SP		1 1/2" SP		1 3/4" SP	
		RPM	BHP	RPM	BHP	RPM	BHP	RPM	BHP	RPM	BHP	RPM	BHP	RPM	BHP	RPM	BHP	RPM	BHP	RPM	BHP
11024	800	264	.65	302	.90	340	1.17	375	1.49	408	1.81	439	2.15	467	2.49	521	3.25	569	4.11	613	4.93
12402	900	279	.79	313	1.05	347	1.32	381	1.64	412	2.00	442	2.36	470	2.73	523	3.50	571	4.34	615	5.25
13780	1000	295	.94	326	1.23	356	1.53	387	1.85	418	2.19	447	2.58	474	2.98	526	3.79	573	4.64	617	5.57
15158	1100	313	1.12	342	1.43	369	1.75	397	2.08	424	2.43	452	2.81	479	3.22	530	4.09	576	4.99	619	5.94
16536	1200	331	1.32	358	1.65	384	2.00	408	2.36	434	2.73	459	3.10	485	3.51	534	4.41	580	5.36	623	6.34
17914	1300	350	1.56	375	1.92	399	2.29	423	2.66	446	3.05	469	3.45	493	3.86	540	4.75	585	5.75	627	6.78
19292	1400	370	1.83	393	2.20	415	2.60	438	2.99	459	3.40	481	3.82	503	4.24	546	5.14	590	6.15	631	7.22
20670	1500	391	2.15	412	2.54	433	2.95	454	3.38	474	3.82	494	4.23	514	4.67	555	5.61	596	6.60	636	7.68
22048	1600	412	2.51	431	2.89	451	3.33	470	3.75	490	4.22	509	4.69	528	5.15	566	6.12	604	7.12	642	8.21
23426	1700	433	2.89	450	3.31	469	3.75	488	4.22	506	4.70	525	5.18	543	5.68	578	6.66	614	7.70	650	8.78
24804	1800	456	3.33	471	3.78	487	4.22	506	4.71	524	5.21	541	5.72	558	6.23	592	7.26	625	8.34	659	9.45
26182	1900	479	3.80	492	4.27	506	4.74	525	5.25	542	5.77	558	6.28	574	6.83	607	7.92	638	9.03	670	10.18
27560	2000			513	4.84	527	5.32	544	5.83	560	6.37	576	6.92	591	7.48	622	8.63	653	9.77	682	10.96
28938	2100			535	5.43	548	5.95	563	6.46	578	7.03	594	7.59	609	8.19	638	9.38	668	10.57	696	11.80
30316	2200			558	6.09	569	6.61	582	7.17	596	7.73	612	8.32	627	8.93	654	10.17	683	11.41	711	12.66
31694	2300					590	7.36	603	7.94	615	8.49	630	9.09	645	9.71	671	11.01	699	12.32	726	13.61
33072	2400					612	8.16	624	8.74	636	9.33	648	9.94	663	10.58	689	11.91	715	13.26	742	14.61
34450	2500					635	9.01	645	9.62	656	10.25	668	10.84	681	11.51	707	12.87	732	14.33	758	15.71
35828	2600							666	10.57	677	11.18	689	11.82	699	12.48	726	13.92	750	15.30	774	16.81
38584	2800							710	12.64	719	13.25	730	14.06	740	14.74	762	16.12	786	17.64	808	19.29
41340	3000							755	15.02	763	15.71	771	16.54	782	17.23	800	18.74	823	20.26	845	21.91
44096	3200									807	18.47	815	19.15	823	19.98	842	21.63	860	23.15	882	24.80
46852	3400									851	21.50	859	22.32	867	23.15	884	24.80	900	26.46	919	28.25
49608	3600									896	24.94	903	25.77	913	26.60	926	28.39	943	30.18	957	31.97

Volume of Air CFM	Outlet Velocity Feet per Minute	2" SP		2 1/2" SP		3" SP		3 1/2" SP		4" SP		4 1/2" SP		5" SP		5 1/2" SP		6" SP		6 1/2" SP	
		RPM	BHP	RPM	BHP	RPM	BHP	RPM	BHP	RPM	BHP	RPM	BHP	RPM	BHP	RPM	BHP	RPM	BHP	RPM	BHP
13780	1000	658	6.55	734	8.70																
15158	1100	660	6.92	736	9.07																
16536	1200	663	7.37	738	9.54																
17914	1300	666	7.83	740	10.05	808	12.44	870	15.02	929	17.78										
19292	1400	670	8.34	743	10.62	810	13.06	872	15.71	931	18.47										
20670	1500	675	8.83	747	11.23	813	13.72	874	16.40	933	19.15										
22048	1600	680	9.36	751	11.86	816	14.47	877	17.09	935	19.98	989	22.87	1041	26.04	1091	29.35	1137	32.80	1183	36.24
23426	1700	686	9.95	756	12.47	820	15.16	880	17.91	938	20.81	992	23.84	1043	27.01	1092	30.18	1139	33.62	1184	37.21
24804	1800	694	10.61	761	13.15	825	15.98	884	18.88	941	21.77	995	24.94	1045	28.11	1094	31.28	1141	34.73	1186	38.31
26182	1900	703	11.37	767	13.92	830	16.67	889	19.71	945	22.74	998	25.91	1048	29.08	1097	32.25	1143	35.83	1188	39.41
27560	2000	713	12.18	774	14.74	835	17.50	894	20.53	949	23.84	1001	27.01	1051	30.32	1100	33.49	1146	37.21	1191	40.79
28938	2100	725	13.05	783	15.71	841	18.47	899	21.50	953	24.80	1005	28.11	1055	31.56	1103	35.00	1149	38.58		
30316	2200	738	13.92	793	16.67	849	19.43	905	22.60	958	25.77	1010	29.21	1059	32.80	1106	36.38	1152	39.96		
31694	2300	752	15.02	804	17.64	858	20.53	911	23.56	964	26.87	1015	30.45	1064	34.04	1110	37.76	1156	41.48		
33072	2400	767	15.98	817	18.88	868	21.63	919	24.80	970	28.11	1020	31.56	1069	35.28	1115	39.14	1160	42.72		
34450	2500	783	17.09	830	19.98	879	23.01	928	26.18	977	29.35	1026	32.93	1074	36.52	1120	40.51	1164	44.37		
35828	2600	799	18.33	845	21.22	891	24.39	938	27.56	985	30.73	1032	34.31	1079	38.03	1125	41.89	1169	46.03		
38584	2800	831	20.81	876	23.98	919	27.28	961	30.59	1005	34.04	1049	37.48	1093	41.20	1136	45.06	1179	49.06		
41340	3000	865	23.56	907	27.01	949	30.45	989	33.90	1028	37.48	1070	41.20	1109	44.92	1152	48.78	1192	52.92		
44096	3200	902	26.60	940	30.18	980	33.76	1019	37.34	1056	41.06	1093	44.92	1132	48.78	1170	52.92	1208	56.91		
46852	3400	939	30.04	976	33.76	1012	37.62	1050	41.48	1086	45.34	1121	49.33	1156	53.33	1192	57.46	1228	61.73		
49608	3600	976	33.76	1012	37.62	1046	41.75	1082	45.75	1117	49.88	1151	54.02	1184	58.15	1217	62.42				
52364	3800	1013	37.90	1049	42.03	1083	46.16	1115	50.43	1149	54.84	1182	58.98	1214	63.39	1245	67.80				
55120	4000	1058	42.58	1086	46.58	1120	50.99	1151	55.40	1181	59.81	1213	64.49	1245	68.90	1275	73.45				

All Capacities Based on Standard Air (Density .075#/cu.ft.—70°F—29.92" Hg. Bar.)

NOTES: (1) Ball bearings are standard on all Type NH, Class II-A Fans. (2) Values underlined indicate the most efficient point of operation for each pressure. (3) When equipped with Vortex Control increase speed 1%.

**CLASS II-A
MAX. RPM
1233**

CLARAGE TYPE NH FANS

NON-OVERLOADING MEDIUM SPEED HIGH EFFICIENCY

**SIZE 80 1/2
DOUBLE WIDTH
DOUBLE INLET**

Outlet Size 58 1/4" x 42 5/8" Outside

Wheel Diameter 40 1/4 in.

Inlet Size 45" Dia. Outside

Outlet Area 16.81 Sq. Ft. Inside

Tip Speed = RPM x 10.54

Max. BHP = 59.70 (RPM/1000)³

Volume of Air CFM	Outlet Velocity ft per M	1/4" SP		3/8" SP		1/2" SP		5/8" SP		3/4" SP		7/8" SP		1" SP		1 1/4" SP		1 1/2" SP		1 3/4" SP	
		RPM	BHP	RPM	BHP	RPM	BHP	RPM	BHP	RPM	BHP	RPM	BHP	RPM	BHP	RPM	BHP	RPM	BHP	RPM	BHP
13448	800	239	0.79	274	1.09	308	1.43	341	1.82	370	2.20	398	2.62	424	3.04	472	3.97	516	5.01	556	6.02
15129	900	253	0.96	284	1.28	315	1.61	345	2.00	374	2.44	401	2.87	427	3.33	474	4.27	518	5.30	558	6.40
16810	1000	268	1.14	296	1.50	324	1.87	351	2.25	379	2.67	405	3.14	430	3.63	477	4.62	520	5.66	560	6.79
18491	1100	284	1.36	310	1.75	334	2.13	360	2.54	385	2.96	410	3.43	435	3.93	480	4.99	522	6.09	562	7.25
20172	1200	300	1.61	324	2.02	348	2.43	370	2.87	393	3.33	417	3.78	440	4.29	484	5.38	526	6.54	565	7.73
21853	1300	317	1.90	340	2.37	362	2.79	383	3.24	404	3.72	426	4.20	447	4.71	489	5.80	530	7.01	568	8.27
23534	1400	336	2.24	356	2.69	377	3.18	397	3.65	417	4.15	436	4.66	456	5.18	495	6.27	535	7.50	572	8.81
25215	1500	355	2.62	373	3.09	393	3.60	411	4.12	430	4.64	448	5.16	466	5.70	503	6.84	540	8.05	577	9.36
26896	1600	374	3.06	390	3.53	409	4.07	426	4.57	444	5.14	461	5.72	479	6.29	513	7.46	548	8.69	582	10.02
28577	1700	393	3.53	408	4.03	425	4.57	442	5.14	459	5.73	475	6.32	493	6.93	524	8.12	557	9.40	590	10.71
30258	1800	413	4.07	427	4.61	442	5.14	459	5.75	475	6.35	490	6.98	507	7.60	537	8.86	567	10.17	598	11.53
31939	1900	434	4.64	446	5.21	459	5.78	476	6.40	491	7.04	506	7.67	521	8.34	551	9.67	579	11.01	608	12.42
33620	2000			465	5.90	478	6.49	493	7.11	508	7.77	522	8.44	536	9.13	565	10.52	592	11.92	619	13.36
35301	2100			485	6.62	498	7.26	510	7.88	525	8.57	538	9.26	552	9.99	579	11.45	606	12.89	631	14.39
36982	2200			506	7.43	517	8.07	528	8.74	542	9.43	555	10.15	568	10.89	593	12.41	620	13.92	645	15.45
38663	2300					536	8.97	547	9.68	559	10.35	572	11.09	585	11.85	609	13.43	634	15.03	659	16.61
40344	2400					555	9.95	566	10.66	576	11.38	589	12.12	602	12.91	625	14.52	649	16.17	673	17.82
42025	2500					576	10.99	585	11.73	595	12.51	606	13.23	618	14.04	642	15.70	664	17.48	687	19.16
43706	2600							604	12.89	614	13.63	625	14.42	634	15.23	659	16.98	680	18.66	702	20.51
47068	2800							644	15.41	652	16.24	662	17.15	671	17.99	691	19.67	713	21.52	733	23.53
50430	3000							685	18.32	691	19.16	700	20.17	709	21.01	726	22.86	746	24.71	766	26.73
53792	3200									730	22.53	739	23.37	747	24.37	764	26.39	780	28.24	799	30.26
57154	3400									772	26.22	779	27.23	786	28.24	802	30.26	817	32.28	832	34.46
60516	3600									814	30.43	819	31.43	828	32.44	840	34.63	855	36.81	868	39.00

Volume of Air CFM	Outlet Velocity ft per M	2" SP		2 1/2" SP		3" SP		3 1/2" SP		4" SP		4 1/2" SP		5" SP		5 1/2" SP		6" SP		6 1/2" SP	
		RPM	BHP	RPM	BHP	RPM	BHP	RPM	BHP	RPM	BHP	RPM	BHP	RPM	BHP	RPM	BHP	RPM	BHP	RPM	BHP
16810	1000	597	7.98	665	10.61																
18491	1100	599	8.44	667	11.06																
20172	1200	601	8.99	669	11.63																
21853	1300	604	9.55	671	12.25	733	15.18	789	18.32	842	21.68										
23534	1400	608	10.17	674	12.96	735	15.94	791	19.16	844	22.53										
25215	1500	612	10.78	677	13.70	737	16.74	793	20.00	846	23.37										
26896	1600	617	11.41	681	14.47	740	17.65	795	20.84	848	24.37	897	27.90	944	31.77	989	35.81	1032	40.01	1073	44.21
28577	1700	622	12.14	685	15.21	744	18.49	798	21.85	850	25.38	899	29.08	946	32.95	991	36.81	1033	41.02	1074	45.39
30258	1800	629	12.94	690	16.04	748	19.50	802	23.03	853	26.56	902	30.43	948	34.29	993	38.16	1035	42.36	1076	46.73
31939	1900	637	13.87	695	16.98	752	20.34	806	24.04	857	27.74	905	31.60	951	35.47	995	39.34	1037	43.71	1078	48.08
33620	2000	647	14.86	702	17.99	757	21.35	810	25.05	861	29.08	908	32.95	954	36.98	997	40.85	1039	45.39	1080	49.76
35301	2100	657	15.92	710	19.16	763	22.53	815	26.22	865	30.26	912	34.29	957	38.49	1000	42.70	1042	47.08		
36982	2200	669	16.98	719	20.34	770	23.70	820	27.57	869	31.43	916	35.64	961	40.01	1003	44.38	1045	48.75		
38663	2300	682	18.32	730	21.52	778	25.05	826	28.75	874	32.78	920	37.15	965	41.52	1007	46.06	1048	50.60		
40344	2400	696	19.50	741	23.03	787	26.56	833	30.26	879	34.29	925	38.49	969	43.03	1011	47.74	1052	52.11		
42025	2500	710	20.84	753	24.37	797	28.07	842	31.94	886	35.81	930	40.18	974	44.55	1015	49.42	1056	54.13		
43706	2600	724	22.36	767	25.89	808	29.75	851	33.62	894	37.49	936	41.86	979	46.40	1020	51.10	1060	56.15		
47068	2800	753	25.38	794	29.25	833	33.28	872	37.32	912	41.52	952	45.72	991	50.26	1030	54.97	1070	59.84		
50430	3000	785	28.75	823	32.95	861	37.15	897	41.35	933	45.72	970	50.26	1006	54.80	1045	59.51	1081	64.55		
53792	3200	818	32.44	853	36.81	889	41.18	924	45.56	958	50.09	992	54.80	1026	59.51	1061	64.55	1095	69.43		
57154	3400	851	36.65	885	41.18	918	45.89	952	50.60	985	55.30	1017	60.18	1048	65.05	1081	70.10	1114	75.31		
60516	3600	884	41.18	918	45.89	949	50.93	981	55.81	1013	60.85	1044	65.90	1074	70.94	1104	76.15				
63878	3800	919	46.23	951	51.27	982	56.31	1011	61.52	1042	66.90	1072	71.95	1101	77.33	1128	82.71				
67240	4000	958	51.94	984	56.82	1016	62.20	1044	67.58	1071	72.96	1100	78.67	1129	84.05	1157	89.60				

All Capacities Based on Standard Air (Density .075#/cu.ft.—70° F.—29.92" Hg. Bar.)

NOTES: (1) Ball bearings are standard on all Type NH, Class II-A Fans. (2) Values underlined indicate the most efficient point of operation for each pressure. (3) When equipped with Vortex Control increase speed 1%.

SIZE 89
DOUBLE WIDTH
DOUBLE INLET

CLARAGE TYPE NH FANS

CLASS II-A
MAX. RPM
1117

NON-OVERLOADING MEDIUM SPEED HIGH EFFICIENCY

Outlet Size 64 1/4" x 47 1/8" Outside

Wheel Diameter 44 1/2 in.

Inlet Size 49" Dia. Outside

Outlet Area 20.55 Sq. Ft. Inside

Tip Speed = RPM x 11.65

Max. BHP = 98.48 (RPM/1000)³

Volume of Air CFM	Outlet Velocity ft per M	1/4" SP		3/8" SP		1/2" SP		5/8" SP		3/4" SP		7/8" SP		1" SP		1 1/4" SP		1 1/2" SP		1 3/4" SP	
		RPM	BHP	RPM	BHP	RPM	BHP	RPM	BHP	RPM	BHP	RPM	BHP	RPM	BHP	RPM	BHP	RPM	BHP	RPM	BHP
16440	800	217	0.97	<u>248</u>	<u>1.34</u>	279	1.75	308	2.22	335	2.69	360	3.21	384	3.72	427	4.85	467	6.12	503	7.36
18495	900	229	1.17	<u>257</u>	<u>1.56</u>	285	1.97	312	2.45	338	2.98	363	3.51	386	4.07	429	5.22	468	6.47	505	7.83
20550	1000	242	1.40	268	1.83	<u>293</u>	<u>2.28</u>	318	2.75	343	3.27	367	3.84	389	4.44	431	5.65	470	6.93	506	8.30
22605	1100	257	1.66	280	2.14	303	2.61	325	3.10	348	3.62	371	4.19	393	4.81	434	6.10	473	7.44	508	8.86
24660	1200	272	1.97	293	2.47	315	2.98	335	3.51	356	4.07	<u>377</u>	<u>4.62</u>	398	5.24	438	6.58	476	7.99	511	9.45
26715	1300	287	2.32	308	2.86	328	3.41	347	3.97	366	4.54	385	5.14	404	5.75	443	7.09	480	8.57	514	10.11
28770	1400	304	2.73	323	3.29	341	3.88	359	4.46	377	5.08	394	5.69	412	6.33	<u>448</u>	<u>7.67</u>	484	9.17	518	10.77
30825	1500	321	3.21	338	3.78	355	4.40	372	5.03	389	5.67	406	6.31	422	6.97	455	8.36	489	9.84	522	11.45
32880	1600	338	3.74	353	4.32	370	4.97	386	5.59	402	6.29	418	6.99	433	7.69	464	9.12	496	10.62	527	12.25
34935	1700	356	4.32	369	4.93	385	5.59	400	6.29	415	7.01	431	7.73	445	8.47	474	9.93	504	11.49	533	13.09
36990	1800	374	4.97	386	5.63	400	6.29	415	7.03	429	7.77	444	8.53	458	9.29	486	10.83	513	12.43	<u>541</u>	<u>14.10</u>
39045	1900	392	5.67	403	6.37	416	7.07	430	7.83	444	8.61	457	9.37	471	10.19	498	11.82	524	13.46	550	15.19
41100	2000			421	7.21	433	7.93	445	8.69	459	9.49	472	10.32	485	11.16	511	12.86	536	14.57	560	16.34
43155	2100			439	8.10	450	8.88	461	9.64	474	10.48	487	11.32	499	12.21	524	13.99	548	15.76	571	17.59
45210	2200			458	9.08	467	9.86	478	10.69	489	11.53	502	12.41	514	13.32	537	15.17	560	17.02	583	18.89
47265	2300					484	10.97	495	11.84	505	12.66	517	13.56	529	14.49	551	16.42	573	18.37	596	20.30
49320	2400					502	12.17	512	13.03	521	13.91	532	14.82	544	15.78	566	17.76	587	19.77	609	21.78
51375	2500					521	13.44	529	14.34	538	15.29	548	16.17	559	17.16	581	19.19	601	21.37	622	23.43
53430	2600							546	15.76	556	16.67	565	17.63	574	18.62	596	20.76	615	22.81	635	25.07
57540	2800							584	18.84	591	19.85	599	20.96	607	21.99	625	24.04	645	26.30	663	28.77
61650	3000							620	22.40	627	23.43	633	24.66	641	25.69	657	27.95	675	30.21	693	32.67
65760	3200									663	27.54	669	28.56	675	29.80	691	32.26	705	34.52	723	36.99
69870	3400									699	32.06	705	33.29	711	34.52	725	36.99	739	39.46	753	42.13
73980	3600									735	37.20	750	38.43	749	39.66	759	42.33	774	45.00	785	47.68

Volume of Air CFM	Outlet Velocity ft per M	2" SP		2 1/2" SP		3" SP		3 1/2" SP		4" SP		4 1/2" SP		5" SP		5 1/2" SP		6" SP		6 1/2" SP	
		RPM	BHP	RPM	BHP	RPM	BHP	RPM	BHP	RPM	BHP	RPM	BHP	RPM	BHP	RPM	BHP	RPM	BHP	RPM	BHP
20550	1000	540	9.8	602	13.0																
22605	1100	542	10.3	603	13.5																
24660	1200	544	11.0	605	14.2																
26715	1300	547	11.7	607	15.0	663	18.6	714	22.4	763	26.5										
28770	1400	550	12.4	610	15.8	665	19.5	716	23.4	764	27.5										
30825	1500	554	13.2	613	16.7	667	20.5	718	24.5	765	28.6										
32880	1600	558	14.0	616	17.7	670	21.6	720	25.5	767	29.8	812	34.1	854	38.8	895	43.8	933	48.9	970	54.0
34935	1700	563	14.8	620	18.6	673	22.6	723	26.7	769	31.0	814	35.6	856	40.3	896	45.0	935	50.1	972	55.5
36990	1800	569	15.8	624	19.6	677	23.8	726	28.2	772	32.5	816	37.2	858	41.9	898	46.6	937	51.8	974	57.1
39045	1900	576	17.0	<u>629</u>	<u>20.8</u>	681	24.9	729	29.4	775	33.9	819	38.6	860	43.4	900	48.1	939	53.4	976	58.8
41100	2000	585	18.2	635	22.0	685	26.1	733	30.6	779	35.6	822	40.3	863	45.2	902	49.9	941	55.5	978	60.8
43155	2100	595	19.5	643	23.4	690	27.5	737	32.0	783	37.0	825	41.9	866	47.1	905	52.2	943	57.5		
45210	2200	605	20.8	651	24.9	697	29.0	742	33.7	787	38.4	829	43.6	869	48.9	908	54.3	945	59.6		
47265	2300	617	22.4	660	26.3	704	30.6	747	35.1	791	40.1	833	45.4	873	50.8	911	56.3	948	61.9		
49320	2400	629	23.8	670	28.2	712	32.5	754	37.0	796	41.9	837	47.1	877	52.6	915	58.4	951	63.7		
51375	2500	642	25.5	681	29.8	721	34.3	762	39.0	802	43.8	842	49.1	881	54.5	919	60.4	955	66.2		
53430	2600	655	27.3	694	31.6	731	36.4	770	41.1	809	45.8	847	51.2	886	56.7	923	62.5	959	68.6		
57540	2800	682	31.0	719	35.8	754	40.7	789	45.6	825	50.8	861	55.9	897	61.4	932	67.2	968	73.2		
61650	3000	710	35.1	744	40.3	779	45.4	811	50.6	844	55.9	878	61.4	910	67.0	945	72.7	978	78.9		
65760	3200	740	39.7	772	45.0	804	50.3	836	55.7	867	61.2	897	67.0	929	72.7	960	78.9	992	84.9		
69870	3400	770	44.8	801	50.3	831	56.1	862	61.9	890	67.6	920	73.6	948	79.5	978	85.7	1008	92.1		
73980	3600	800	50.3	831	56.1	859	62.3	888	68.2	916	74.4	945	80.6	972	86.7	998	93.1				
78090	3800	831	56.5	861	62.5	889	68.8	915	75.2	942	81.8	970	88.0	996	94.5	1022	101.1				
82200	4000	867	63.5	891	69.5	919	76.0	944	82.6	969	89.2	996	96.2	1022	102.8	1047	109.5				

All Capacities Based on Standard Air (Density .075#/cu.ft.—70° F.—29.92" Hg. Bar.)

NOTES: (1) Ball bearings are standard on all Type NH, Class II-A Fans. (2) Values underlined indicate the most efficient point of operation for each pressure. (3) When equipped with Vortex Control increase speed 1%.

**CLASS II-A
MAX. RPM
1013**

CLARAGE TYPE NH FANS

NON-OVERLOADING MEDIUM SPEED HIGH EFFICIENCY

SIZE 98

**DOUBLE WIDTH
DOUBLE INLET**

Outlet Size 70⁷/₈" x 51³/₄" Outside

Wheel Diameter 49 in.

Inlet Size 54" Dia. Outside

Outlet Area 24.94 Sq. Ft. Inside

Tip Speed = RPM × 12.83

**Max. BHP = 159.6 (RPM)³
1000**

Volume of Air CFM	Outlet Velocity ft per M	1/4" SP		3/8" SP		1/2" SP		5/8" SP		3/4" SP		7/8" SP		1" SP		1 1/4" SP		1 1/2" SP		1 3/4" SP	
		RPM	BHP	RPM	BHP	RPM	BHP	RPM	BHP	RPM	BHP	RPM	BHP	RPM	BHP	RPM	BHP	RPM	BHP	RPM	BHP
19952	800	197	1.17	225	1.62	253	2.12	280	2.69	304	3.27	327	3.89	348	4.51	388	6.14	424	7.43	457	8.93
22446	900	208	1.42	233	1.90	258	2.39	284	2.97	307	3.62	330	4.26	350	4.94	389	6.33	425	7.86	458	9.50
24940	1000	220	1.70	243	2.22	266	2.77	288	3.34	311	3.96	333	4.66	353	5.39	392	6.86	427	8.40	460	10.07
27434	1100	233	2.02	255	2.59	275	3.17	295	3.77	316	4.39	337	5.09	357	5.84	395	7.41	430	9.03	462	10.75
29928	1200	247	2.39	267	2.99	286	3.62	304	4.26	323	4.94	341	5.61	361	6.36	398	7.98	433	9.70	464	11.47
32422	1300	261	2.82	279	3.47	297	4.14	315	4.81	332	5.51	349	6.24	367	6.98	402	8.60	436	10.40	467	12.27
34916	1400	276	3.32	293	3.99	309	4.71	326	5.41	342	6.16	358	6.91	375	7.68	407	9.30	439	11.12	470	13.07
37410	1500	291	3.89	307	4.59	322	5.34	338	6.11	353	6.88	368	7.66	383	8.45	413	10.15	444	11.95	474	13.89
39904	1600	307	4.54	321	5.24	336	6.04	350	6.78	365	7.63	379	8.48	393	9.33	422	11.07	450	12.89	478	14.86
42398	1700	323	5.24	335	5.99	350	6.78	364	7.63	377	8.50	391	9.38	404	10.28	431	12.05	458	13.94	484	15.89
44892	1800	340	6.04	350	6.83	364	7.63	377	8.53	390	9.43	403	10.35	416	11.27	441	13.14	466	15.09	491	17.11
47386	1900	357	6.88	366	7.73	378	8.58	390	9.50	403	10.45	415	11.37	428	12.37	452	14.34	476	16.34	499	18.43
49880	2000			382	8.75	393	9.63	404	10.55	417	11.52	428	12.52	440	13.54	464	15.61	486	17.68	508	19.83
52374	2100			399	9.83	408	10.77	418	11.70	431	12.72	442	13.74	453	14.81	476	16.98	497	19.12	519	21.35
54868	2200			416	11.02	424	11.97	433	12.97	445	13.99	456	15.06	466	16.16	488	18.41	509	20.65	530	22.92
57362	2300					440	13.32	449	14.37	459	15.36	470	16.46	480	17.58	500	19.93	521	22.30	541	24.64
59856	2400					456	14.76	465	15.81	474	16.88	484	17.98	494	19.15	513	21.55	533	23.99	553	26.44
62350	2500					473	16.31	481	17.41	489	18.56	498	19.63	508	20.82	526	23.29	546	25.94	565	28.43
64844	2600							497	19.13	505	20.23	513	21.40	522	22.60	540	25.19	559	27.68	577	30.43
69832	2800							530	22.87	536	24.09	544	25.44	552	26.69	568	29.18	586	31.90	602	34.92
74820	3000							563	27.18	569	28.43	575	29.93	582	31.18	597	33.91	613	36.66	629	39.65
79808	3200									603	33.42	607	34.67	613	36.16	628	39.16	640	41.90	657	44.89
84796	3400									634	38.91	640	40.40	646	41.90	659	44.89	671	47.88	685	51.13
89784	3600									668	45.14	673	46.64	680	48.13	690	51.38	703	54.62	713	57.86

Volume of Air CFM	Outlet Velocity ft per M	2" SP		2 1/2" SP		3" SP		3 1/2" SP		4" SP		4 1/2" SP		5" SP		5 1/2" SP		6" SP		6 1/2" SP	
		RPM	BHP	RPM	BHP	RPM	BHP	RPM	BHP	RPM	BHP	RPM	BHP	RPM	BHP	RPM	BHP	RPM	BHP	RPM	BHP
24940	1000	490	11.8	547	15.7																
27434	1100	492	12.5	548	16.4																
29928	1200	494	13.3	549	17.3																
32422	1300	496	14.2	551	18.2	602	22.5	648	27.2	692	32.2										
34916	1400	499	15.1	553	19.2	604	23.6	650	28.4	693	33.4										
37410	1500	503	16.0	556	20.3	606	24.8	652	29.7	695	34.7										
39904	1600	507	16.9	559	21.5	608	26.2	654	30.9	697	36.2	737	41.4	776	47.1	812	53.1	847	59.4	881	65.6
42398	1700	511	18.0	563	22.6	611	27.4	656	32.4	699	37.7	739	43.1	777	48.9	814	54.6	848	60.9	882	67.3
44892	1800	517	19.2	567	23.8	614	28.9	659	34.2	701	39.4	741	45.1	779	50.9	816	56.6	850	62.8	884	69.3
47386	1900	523	20.6	571	25.2	618	30.2	662	35.7	704	41.2	743	46.9	781	52.6	818	58.4	852	64.8	886	71.3
49880	2000	531	22.0	577	26.7	622	31.7	666	37.2	707	43.1	746	48.9	783	54.9	820	60.6	854	67.3	888	73.8
52374	2100	540	23.6	584	28.4	627	33.4	670	38.9	710	44.9	749	50.9	786	57.1	822	63.3	856	69.8		
54868	2200	550	25.2	591	30.2	633	35.2	674	40.9	714	46.6	752	52.9	789	59.4	824	65.8	858	72.3		
57362	2300	561	27.2	599	31.9	639	37.2	679	42.6	718	48.6	756	55.1	792	61.6	827	68.3	861	75.1		
59856	2400	572	28.9	609	34.2	647	39.4	685	44.9	722	50.9	760	57.1	796	63.8	830	70.8	864	77.3		
62350	2500	583	30.9	619	36.2	655	41.6	692	47.4	726	53.1	764	59.6	800	66.1	834	73.3	868	80.3		
64844	2600	595	33.2	630	38.4	664	44.1	699	49.9	734	55.6	769	62.1	804	68.8	838	75.8	872	83.3		
69832	2800	619	37.7	653	43.4	685	49.4	716	55.4	749	61.6	782	67.8	814	74.6	847	81.6	879	88.8		
74820	3000	645	42.6	676	48.9	707	55.1	737	61.4	766	67.8	797	74.6	827	81.3	859	88.3	888	95.8		
79808	3200	672	48.1	701	54.6	730	61.1	759	67.6	787	74.3	815	81.3	843	88.3	872	95.8	900	103.0		
84796	3400	699	54.4	727	61.1	754	68.1	782	75.1	809	82.1	835	89.3	861	96.5	888	104.0	915	111.7		
89784	3600	726	61.1	754	68.1	780	75.6	806	82.8	832	90.3	858	97.8	882	105.2	907	113.0				
94772	3800	755	68.6	782	76.1	807	83.5	831	91.3	856	99.3	881	106.7	905	114.7	928	122.7				
99760	4000	787	77.1	810	84.3	834	92.3	857	100.3	880	108.2	904	116.7	928	124.7	950	132.9				

All Capacities Based on Standard Air (Density .075#/cu.ft.—70° F.—29.92" Hg. Bar.)

NOTES: (1) Ball bearings are standard on all Type NH, Class II-A Fans. (2) Values underlined indicate the most efficient point of operation for each pressure. (3) When equipped with Vortex Control increase speed 1%.

CLASS II-A
MAX. RPM
828

CLARAGE TYPE NH FANS

SIZE 120
DOUBLE WIDTH
DOUBLE INLET

NON-OVERLOADING MEDIUM SPEED HIGH EFFICIENCY

Outlet Size 86½" x 63⅞" Outside

Wheel Diameter 60 in.

Inlet Size 65" Dia. Outside

Outlet Area 37.26 Sq. Ft. Inside

Tip Speed = RPM × 15.71

Max. BHP = 439.1 $\left(\frac{\text{RPM}}{1000}\right)^3$

Volume of Air CFM	Outlet Velocity ft per M	¼" SP		⅓" SP		½" SP		⅘" SP		¾" SP		1" SP		1¼" SP		1½" SP		1¾" SP			
		RPM	BHP	RPM	BHP	RPM	BHP	RPM	BHP	RPM	BHP	RPM	BHP	RPM	BHP	RPM	BHP	RPM	BHP	RPM	BHP
29808	800	161	1.75	184	2.42	207	3.17	228	4.02	248	4.88	267	5.81	284	6.74	317	8.79	346	11.10	373	13.34
33534	900	170	2.12	190	2.83	211	3.58	232	4.43	251	5.40	269	6.37	286	7.38	318	9.46	347	11.74	374	14.20
37260	1000	180	2.53	199	3.32	217	4.14	236	4.99	254	5.92	272	6.97	289	8.05	320	10.25	349	12.56	375	15.05
40986	1100	191	3.02	208	3.88	224	4.73	241	5.63	258	6.56	275	7.60	292	8.72	322	11.07	351	13.49	377	16.06
44712	1200	202	3.58	218	4.47	233	5.40	249	6.37	264	7.38	280	8.38	295	9.50	325	11.92	353	14.49	379	17.14
48438	1300	213	4.21	228	5.18	243	6.19	257	7.19	271	8.23	285	9.32	300	10.43	328	12.85	356	15.54	381	18.33
52164	1400	225	4.96	239	5.96	253	7.04	266	8.09	280	9.20	292	10.32	306	11.48	332	13.90	359	16.62	384	19.52
55890	1500	238	5.81	250	6.86	263	7.97	276	9.13	289	10.28	301	11.44	313	12.63	338	15.16	363	17.85	387	20.75
59616	1600	250	6.78	261	7.82	274	9.02	286	10.13	298	11.40	310	12.67	321	13.94	344	16.54	368	19.26	391	22.21
63342	1700	263	7.82	274	8.94	285	10.13	297	11.40	308	12.71	319	14.01	330	15.35	352	18.00	374	20.83	396	23.73
67068	1800	277	9.02	286	10.21	296	11.40	308	12.74	319	14.08	329	15.46	339	16.84	360	19.64	381	22.54	401	25.56
70794	1900	291	10.28	299	11.55	308	12.82	319	14.20	330	15.61	339	16.99	349	18.48	369	21.42	388	24.41	408	27.54
74520	2000			312	13.08	320	14.38	330	15.76	341	17.21	350	18.70	359	20.23	378	23.32	397	26.42	415	29.62
78246	2100			326	14.68	333	16.10	342	17.47	352	19.00	361	20.53	370	22.13	388	25.37	406	28.58	423	31.89
81972	2200			340	16.47	346	17.88	354	19.38	363	20.90	372	22.51	381	24.14	398	27.50	415	30.85	432	34.24
85698	2300					359	19.90	367	21.46	374	22.95	383	24.59	392	26.27	408	29.77	425	33.31	441	36.81
89424	2400					373	22.06	380	23.62	386	25.23	394	26.86	403	28.62	419	32.19	435	35.84	451	39.50
93150	2500					387	24.37	393	26.01	399	27.72	406	29.32	414	31.11	430	34.80	446	38.75	461	42.48
96876	2600							406	28.58	412	30.22	419	31.97	426	33.76	441	37.63	457	41.36	471	45.46
104328	2800							433	34.17	438	35.99	444	38.01	450	39.87	464	43.59	479	47.69	492	52.16
111780	3000							460	40.61	465	42.48	469	44.71	476	46.58	487	50.67	501	54.77	514	59.24
119232	3200									492	49.93	496	51.79	502	54.03	512	58.50	523	62.60	536	67.07
126684	3400									519	58.13	523	60.36	528	62.60	538	67.07	548	71.54	558	76.38
134136	3600									546	67.44	550	69.68	555	71.91	564	76.76	574	81.60	582	86.44

Volume of Air CFM	Outlet Velocity ft per M	2" SP		2½" SP		3" SP		3½" SP		4" SP		4½" SP		5" SP		5½" SP		6" SP		6½" SP	
		RPM	BHP	RPM	BHP	RPM	BHP	RPM	BHP	RPM	BHP	RPM	BHP	RPM	BHP	RPM	BHP	RPM	BHP	RPM	BHP
37260	1000	401	17.7	447	23.5																
40986	1100	402	18.7	448	24.5																
44712	1200	403	19.9	449	25.8																
48438	1300	405	21.2	450	27.2	491	33.6	530	40.6	565	48.1										
52164	1400	408	22.5	452	28.7	493	35.3	531	42.5	566	49.9										
55890	1500	411	23.9	454	30.4	495	37.1	532	44.3	567	51.8										
59616	1600	414	25.3	457	32.1	497	39.1	534	46.2	569	54.0	603	61.9	634	70.4	664	79.4	693	88.7	720	98.0
63342	1700	417	26.9	460	33.7	499	41.0	536	48.4	571	56.3	604	64.5	635	73.0	665	81.6	694	90.9	721	100.6
67068	1800	422	28.7	463	35.5	502	43.2	538	51.0	573	58.9	605	67.4	636	76.0	666	84.6	695	93.9	722	103.6
70794	1900	427	30.7	467	37.6	505	45.1	541	53.3	575	61.5	607	70.0	638	78.6	667	87.2	696	96.9	723	106.6
74520	2000	434	32.9	471	39.9	508	47.3	544	55.5	577	64.5	609	73.0	640	82.0	669	90.5	697	100.6	725	110.3
78246	2100	441	35.3	477	42.5	512	49.9	547	58.1	580	67.1	612	76.0	642	85.3	671	94.6	699	104.3		
81972	2200	449	37.6	483	45.1	517	52.5	550	61.1	583	69.7	615	79.0	644	88.7	673	98.4	701	108.1		
85698	2300	458	40.6	489	47.7	522	55.5	554	63.7	586	72.7	618	82.3	647	92.0	676	102.1	703	112.2		
89424	2400	467	43.2	497	51.0	528	58.9	559	67.1	590	76.0	621	85.3	650	95.4	679	105.8	706	115.5		
93150	2500	476	46.2	505	54.0	535	62.2	565	70.8	594	79.4	624	89.1	653	98.7	682	109.5	709	120.0		
96876	2600	486	49.6	514	57.4	543	66.0	571	74.5	600	83.1	628	92.8	657	102.8	685	113.3	712	124.4		
104328	2800	506	56.3	533	64.8	559	73.8	585	82.7	612	92.0	638	101.3	665	111.4	691	121.8	718	132.6		
111780	3000	527	63.7	552	73.0	577	82.3	602	91.7	626	101.3	651	111.4	675	121.5	701	131.9	725	143.1		
119232	3200	549	71.9	572	81.6	596	91.3	620	101.0	643	111.0	665	121.5	689	131.9	712	143.1	735	153.9		
126684	3400	571	81.2	594	91.3	616	101.7	639	112.2	661	122.6	682	133.4	703	144.2	725	155.4	747	166.9		
134136	3600	593	91.3	616	101.7	637	112.9	658	123.7	680	134.9	700	146.1	720	157.2	740	168.8				
141588	3800	617	102.5	638	113.6	659	124.8	679	136.4	699	148.3	719	159.5	739	171.4	758	183.3				
149040	4000	643	115.1	660	125.9	681	137.9	700	149.8	719	161.7	738	174.4	758	186.3	776	198.6				

All Capacities Based on Standard Air (Density .075#/cu.ft.—70°F.—29.92" Hg. Bar.)

NOTES: (1) Ball bearings are standard on all Type NH, Class II-A Fans. (2) Values underlined indicate the most efficient point of operation for each pressure. (3) When equipped with Vortex Control increase speed 1%.

SIZE 132
DOUBLE WIDTH
DOUBLE INLET

CLARAGE TYPE NH FANS

CLASS II-A
MAX. RPM
753

NON-OVERLOADING MEDIUM SPEED HIGH EFFICIENCY

Outlet Size 95 1/8" x 69 5/8" Outside

Wheel Diameter 66 in.

Inlet Size 72" Dia. Outside

Outlet Area 45.14 Sq. Ft. Inside

Tip Speed = RPM x 17.28

Max. BHP = 707.2 (RPM/1000)³

Volume of Air CFM	Outlet Velocity ft per M	1/4" SP		3/8" SP		1/2" SP		5/8" SP		3/4" SP		7/8" SP		1" SP		1 1/4" SP		1 1/2" SP		1 3/4" SP	
		RPM	BHP	RPM	BHP	RPM	BHP	RPM	BHP	RPM	BHP	RPM	BHP	RPM	BHP	RPM	BHP	RPM	BHP	RPM	BHP
36112	800	146	2.12	167	2.93	188	3.84	208	4.88	226	5.91	243	7.04	259	8.17	288	10.65	315	13.45	339	16.16
40626	900	154	2.57	173	3.43	192	4.33	211	5.37	228	6.55	245	7.72	260	8.94	289	11.47	316	14.22	340	17.20
45140	1000	163	3.07	181	4.02	197	5.01	214	6.05	231	7.18	247	8.44	262	9.75	291	12.41	317	15.21	341	18.24
49654	1100	173	3.66	189	4.69	204	5.73	219	6.82	235	7.94	250	9.21	265	10.56	293	13.41	319	16.34	342	19.46
54168	1200	183	4.33	198	5.42	212	6.55	226	7.72	240	8.94	254	10.16	268	11.51	296	14.44	321	17.56	344	20.76
58682	1300	193	5.10	208	6.27	221	7.49	234	8.71	246	9.98	260	11.29	273	12.64	299	15.57	323	18.82	346	22.21
63196	1400	204	6.00	218	7.22	230	8.53	242	9.80	254	11.15	266	12.50	278	13.90	302	16.84	326	20.13	349	23.65
67710	1500	216	7.04	228	8.31	240	9.66	251	11.06	262	12.46	273	13.86	284	15.30	307	18.37	330	21.62	352	25.14
72224	1600	228	8.22	238	9.48	250	10.92	260	12.28	271	13.81	282	15.35	292	16.88	313	20.04	334	23.34	355	26.90
76738	1700	240	9.48	249	10.83	260	12.28	270	13.81	280	15.39	291	16.97	300	18.60	320	21.85	340	25.23	360	28.75
81252	1800	252	10.92	260	12.37	270	13.81	280	15.44	290	17.06	300	18.73	309	20.40	327	23.79	346	27.31	365	30.97
85766	1900	264	12.46	272	13.99	280	15.53	290	17.20	300	18.91	309	20.58	318	22.39	335	25.96	353	29.57	371	33.36
90280	2000			284	15.84	291	17.42	300	19.09	310	20.85	318	22.66	327	24.51	344	28.26	361	32.00	377	35.87
94794	2100			296	17.79	302	19.50	311	21.17	320	23.02	327	24.87	336	26.81	353	30.74	369	34.62	385	38.64
99308	2200			309	19.95	314	21.67	322	23.47	330	25.32	337	27.26	346	29.25	362	33.31	378	37.38	393	41.48
103822	2300					326	24.10	333	26.00	340	27.81	347	29.79	356	31.82	371	36.07	387	40.36	402	44.60
108336	2400					339	26.72	344	28.62	351	30.56	358	32.55	366	34.67	381	39.00	396	43.42	411	47.85
112850	2500					352	29.52	356	31.51	363	33.58	370	35.53	377	37.69	391	42.16	405	46.95	420	51.46
117364	2600							368	34.62	375	36.61	382	38.73	388	40.90	401	45.59	415	50.11	429	55.07
126392	2800							394	41.39	398	43.61	404	46.04	410	48.30	422	52.81	435	57.78	447	63.20
135420	3000							418	49.20	422	51.46	427	54.17	433	56.43	443	61.39	455	66.36	467	71.77
144448	3200									447	60.49	451	62.74	456	65.45	466	70.87	475	75.84	487	81.25
153476	3400									472	70.42	475	73.13	480	75.84	489	81.25	498	86.67	508	92.54
162504	3600									497	81.70	500	84.41	505	87.12	512	92.99	522	98.86	529	104.72

Volume of Air CFM	Outlet Velocity ft per M	2" SP		2 1/2" SP		3" SP		3 1/2" SP		4" SP		4 1/2" SP		5" SP		5 1/2" SP		6" SP		6 1/2" SP	
		RPM	BHP	RPM	BHP	RPM	BHP	RPM	BHP	RPM	BHP	RPM	BHP	RPM	BHP	RPM	BHP	RPM	BHP	RPM	BHP
45140	1000	364	21.4	406	28.5																
49654	1100	365	22.7	407	29.7																
54168	1200	367	24.1	408	31.2																
58682	1300	369	25.6	409	32.9	447	40.8	482	49.2	514	58.2										
63196	1400	371	27.3	411	34.8	448	42.8	483	51.5	515	60.5										
67710	1500	373	28.9	413	36.8	450	45.0	484	53.7	516	62.7										
72224	1600	376	30.7	415	38.9	452	47.4	485	56.0	517	65.5	548	74.9	576	85.3	603	96.1	630	107.4	654	118.7
76738	1700	379	32.6	418	40.9	454	49.7	487	58.7	519	68.2	549	78.1	577	88.5	604	98.9	631	110.1	655	121.9
81252	1800	384	34.8	421	43.1	456	52.4	489	61.8	521	71.3	550	81.7	578	92.1	605	102.5	632	113.8	656	125.5
85766	1900	389	37.2	424	45.6	459	54.6	491	64.6	523	74.5	552	84.9	580	95.2	606	105.6	633	117.5	657	129.1
90280	2000	394	39.9	428	48.3	462	57.3	494	67.3	525	78.1	554	88.5	582	99.3	608	109.7	634	121.9	659	133.6
94794	2100	401	42.7	433	51.5	465	60.5	497	70.4	527	81.3	556	92.1	584	103.4	610	114.7	636	126.4		
99308	2200	408	45.6	439	54.6	470	63.6	500	74.0	530	84.4	558	95.7	586	107.4	612	119.2	638	130.9		
103822	2300	416	49.2	445	57.8	475	67.3	504	77.2	533	88.0	561	99.8	588	111.5	614	123.7	640	135.9		
108336	2400	424	52.4	452	61.8	480	71.4	508	81.3	536	92.1	564	103.4	591	115.6	617	128.2	642	139.9		
112850	2500	433	56.0	459	65.5	486	75.4	513	85.8	540	96.1	567	107.9	594	119.6	620	132.7	644	145.4		
117364	2600	442	60.0	468	69.5	493	79.9	519	90.3	545	100.7	571	112.4	597	124.6	624	137.2	647	150.8		
126392	2800	459	68.2	484	78.5	508	89.4	532	100.2	556	111.5	580	122.8	604	135.0	629	147.6	653	160.7		
135420	3000	479	77.2	502	88.5	525	99.8	547	111.0	569	122.8	592	135.0	614	147.2	637	159.8	659	173.3		
144448	3200	499	87.1	520	98.9	542	110.6	564	122.3	584	134.5	605	147.2	626	159.8	647	173.3	668	186.4		
153476	3400	519	98.4	540	110.6	560	123.2	581	135.9	601	148.5	620	161.6	639	174.7	659	188.2	679	202.2		
162504	3600	539	110.6	560	123.2	579	136.8	598	149.9	618	163.4	637	176.9	655	190.5	673	204.5				
171532	3800	560	124.1	581	137.7	599	151.2	617	165.2	635	179.7	654	193.2	672	207.6	689	222.1				
180560	4000	585	139.5	602	152.6	619	167.0	637	181.5	654	195.9	671	211.3	689	225.7	706	240.6				

All Capacities Based on Standard Air (Density .075#/cu.ft.—70°F.—29.92" Hg. Bar.)

NOTES: (1) Ball bearings are standard on all Type NH, Class II-A Fans. (2) Values underlined indicate the most efficient point of operation for each pressure. (3) When equipped with Vortex Control increase speed 1%.

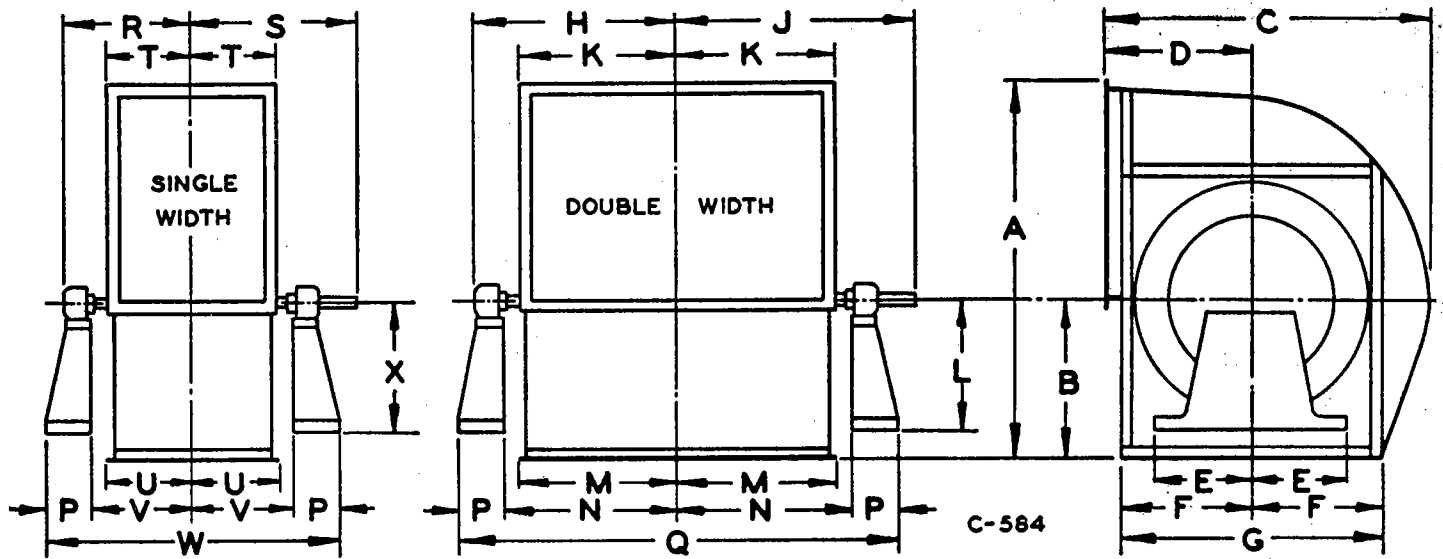

Fan Size	A	B	C	D	E	F	G	H	J	K	L	M	N	P	Q
30	31 ⁷ / ₈	14	28 ⁷ / ₁₆	14 ¹ / ₄	10 ¹ / ₂	12 ¹ / ₈	24 ¹ / ₄	17 ⁷ / ₁₆	21 ¹³ / ₁₆	12 ³ / ₄	11	12 ³ / ₄	13 ¹⁵ / ₁₆	5 ¹ / ₂	38 ⁷ / ₈
33	34 ¹ / ₈	14 ³ / ₄	30 ⁵ / ₁₆	15	10 ¹ / ₂	12 ⁷ / ₈	25 ³ / ₄	17 ⁷ / ₈	22 ³ / ₈	13 ¹⁵ / ₁₆	11	13 ¹⁵ / ₁₆	14 ¹ / ₂	5 ¹ / ₂	40
36 ¹ / ₂	37 ¹ / ₂	16 ¹ / ₄	32 ¹⁵ / ₁₆	16	12 ¹ / ₄	14	28	19 ¹⁵ / ₁₆	24 ⁹ / ₁₆	15 ³ / ₈	14 ³ / ₈	15 ³ / ₁₆	15 ¹⁵ / ₁₆	6 ¹ / ₈	45 ⁵ / ₈
40	40 ³ / ₈	17 ¹ / ₂	35 ¹ / ₂	17	12 ¹ / ₄	15	30	21 ¹ / ₈	26 ¹ / ₈	16 ¹ / ₂	14 ³ / ₈	16 ¹ / ₂	17 ¹ / ₄	6 ⁷ / ₈	48 ¹ / ₄
44 ¹ / ₂	44 ³ / ₄	19 ¹ / ₄	38 ¹⁵ / ₁₆	18 ¹ / ₂	12 ¹ / ₄	16 ¹ / ₂	33	22 ⁵ / ₈	27 ⁵ / ₈	18	14 ³ / ₈	18	18 ³ / ₄	6 ⁷ / ₈	51 ¹ / ₄
49	48 ³ / ₄	21	42 ¹ / ₈	19 ¹ / ₂	14 ¹ / ₂	17 ¹ / ₂	35	25 ¹ / ₂	30 ³ / ₄	19 ³ / ₄	17 ¹ / ₂	19 ³ / ₄	21	7 ⁷ / ₈	57 ³ / ₄
54	53 ³ / ₈	23	46 ¹⁵ / ₁₆	22	14 ¹ / ₂	19 ¹ / ₂	39	27 ¹ / ₂	32 ³ / ₄	21 ¹ / ₈	17 ¹ / ₂	21 ¹ / ₈	23	7 ⁷ / ₈	61 ³ / ₄
60	58 ³ / ₄	25 ¹ / ₄	51 ¹ / ₈	23 ¹ / ₂	14 ³ / ₄	21	42	29 ¹³ / ₁₆	35 ⁷ / ₁₆	23 ³ / ₁₆	21 ³ / ₄	23 ³ / ₁₆	25 ¹ / ₈	8 ³ / ₈	67
66	64 ¹ / ₈	27 ¹ / ₂	55 ⁵ / ₁₆	25	14 ³ / ₄	22 ¹ / ₂	45	32 ⁵ / ₁₆	37 ¹⁵ / ₁₆	25 ¹³ / ₁₆	21 ³ / ₄	26 ¹³ / ₁₆	27 ⁵ / ₈	8 ³ / ₈	72
73	70 ¹ / ₄	30	60 ¹ / ₂	27	14 ³ / ₄	24 ¹ / ₂	49	35 ¹ / ₈	41 ³ / ₈	28 ⁵ / ₁₆	26 ¹ / ₄	29 ⁵ / ₁₆	30 ¹ / ₄	8 ³ / ₈	77 ¹ / ₄
80 ¹ / ₂	77 ⁷ / ₁₆	33	64 ³ / ₄	28	14 ³ / ₄	25 ¹ / ₂	51	40 ¹ / ₂	46 ³ / ₄	31 ¹ / ₈	26 ³ / ₄	31 ¹⁵ / ₁₆	34 ³ / ₈	8 ³ / ₈	85 ¹ / ₂
89	85 ³ / ₁₆	36 ¹ / ₄	71 ³ / ₈	30 ³ / ₄	14 ³ / ₄	28	56	43 ⁷ / ₈	50 ¹ / ₈	34 ¹ / ₈	26 ³ / ₄	34 ¹⁵ / ₁₆	37 ³ / ₄	8 ³ / ₈	92 ¹ / ₄
98	93 ⁷ / ₈	40 ¹ / ₄	78 ³ / ₄	34	17 ¹ / ₂	30 ¹ / ₂	61	47 ⁵ / ₈	54 ¹ / ₈	37 ⁷ / ₁₆	29 ³ / ₈	38 ³ / ₄	41 ¹ / ₂	9 ³ / ₈	101 ³ / ₄
108 ¹ / ₂	103 ³ / ₈	44 ¹ / ₄	86 ³ / ₄	37 ¹ / ₄	17 ¹ / ₂	33	66	51 ⁷ / ₈	59 ³ / ₈	41 ¹ / ₈	29 ⁵ / ₈	42 ⁷ / ₁₆	45 ¹ / ₈	9 ³ / ₈	109
120	115 ¹ / ₂	49 ¹ / ₄	96	41 ¹ / ₄	19	36 ¹ / ₂	73	58	66	46 ¹ / ₄	35 ⁵ / ₈	47 ¹ / ₁₆	50 ¹ / ₂	11 ¹ / ₂	124
132	126 ⁷ / ₁₆	54	105 ¹ / ₂	45 ¹ / ₄	18	40	80	63	71 ¹ / ₂	50 ⁵ / ₁₆	37 ⁷ / ₈	51 ⁵ / ₁₆	54 ¹ / ₂	11 ¹ / ₄	131 ¹ / ₂

Fan Size	R	S	T	U	V	W	X	SHAFT EXTENSION				Keyway in Drive Hub	
								SW		DW		SW & DW	
								Dia.	Length	Dia.	Length	Width	Depth
30	12 ¹¹ / ₁₆	17 ¹ / ₁₆	8	8	9 ⁹ / ₁₆	29 ³ / ₈	11	1 ³ / ₁₆	4 ¹ / ₄	1 ³ / ₁₆	4 ¹ / ₄	1/4	1/8
33	12 ³ / ₈	17 ¹ / ₈	8 ¹¹ / ₁₆	8 ¹¹ / ₁₆	9 ¹ / ₄	29 ¹ / ₂	11	1 ³ / ₁₆	4 ¹ / ₄	1 ³ / ₁₆	4 ¹ / ₄	1/4	1/8
36 ¹ / ₂	14 ³ / ₁₆	18 ¹³ / ₁₆	9 ⁷ / ₁₆	9 ⁷ / ₁₆	10 ³ / ₁₆	34 ¹ / ₈	14 ³ / ₈	1 ⁵ / ₁₆	4 ¹ / ₂	1 ⁵ / ₁₆	4 ¹ / ₂	5/16	1/8
40	14 ³ / ₄	19 ³ / ₄	10 ¹ / ₈	10 ¹ / ₈	10 ⁷ / ₈	35 ¹ / ₂	14 ³ / ₈	1 ⁷ / ₁₆	4 ³ / ₄	1 ⁷ / ₁₆	4 ³ / ₄	3/8	3/16
44 ¹ / ₂	15 ⁵ / ₈	20 ⁵ / ₈	11	11	11 ³ / ₄	37 ¹ / ₄	14 ³ / ₈	1 ⁷ / ₁₆	4 ³ / ₄	1 ⁷ / ₁₆	4 ³ / ₄	3/8	3/16
49	17 ⁷ / ₁₆	22 ¹⁵ / ₁₆	11 ¹¹ / ₁₆	11 ¹⁵ / ₁₆	13 ³ / ₁₆	42 ¹ / ₈	17 ¹ / ₂	1 ¹¹ / ₁₆	5	1 ¹¹ / ₁₆	5	3/8	3/16
54	18 ⁷ / ₈	24 ¹ / ₈	12 ¹⁵ / ₁₆	12 ¹⁵ / ₁₆	14 ³ / ₈	44 ¹ / ₂	17 ¹ / ₂	1 ¹¹ / ₁₆	5	1 ¹¹ / ₁₆	5	3/8	3/16
60	20 ⁷ / ₁₆	25 ¹⁵ / ₁₆	14 ¹ / ₁₆	14 ¹ / ₁₆	15 ⁵ / ₈	48	21 ³ / ₄	1 ¹⁵ / ₁₆	5 ¹ / ₄	1 ¹⁵ / ₁₆	5 ¹ / ₄	1/2	1/4
66	21 ¹⁵ / ₁₆	27 ⁷ / ₁₆	15 ⁵ / ₁₆	16 ⁵ / ₁₆	17 ¹ / ₈	51	21 ³ / ₄	1 ¹⁵ / ₁₆	5 ¹ / ₄	1 ¹⁵ / ₁₆	5 ¹ / ₄	1/2	1/4
73	23 ¹ / ₂	29 ³ / ₄	16 ¹¹ / ₁₆	17 ¹¹ / ₁₆	18 ⁵ / ₈	54	26 ¹ / ₄	2 ³ / ₁₆	5 ³ / ₄	2 ³ / ₁₆	5 ³ / ₄	1/2	1/4
80 ¹ / ₂	26 ³ / ₄	32 ³ / ₄	18 ¹ / ₈	19 ¹ / ₈	21 ⁵ / ₈	60	26 ¹ / ₂	2 ⁷ / ₁₆	6	2 ¹¹ / ₁₆	6 ¹ / ₄	5/8	5/16
89	29 ³ / ₄	36	19 ¹³ / ₁₆	20 ¹³ / ₁₆	23 ⁵ / ₈	64	26 ³ / ₄	2 ¹¹ / ₁₆	6 ¹ / ₄	2 ¹¹ / ₁₆	6 ¹ / ₄	5/8	5/16
98	32	38 ¹ / ₂	21 ⁵ / ₈	23 ¹ / ₈	25 ⁵ / ₈	70 ¹ / ₂	29 ³ / ₈	2 ¹⁵ / ₁₆	6 ¹ / ₂	2 ¹⁵ / ₁₆	6 ¹ / ₂	3/4	3/8
108 ¹ / ₂	34	40 ¹ / ₂	23 ¹¹ / ₁₆	25 ³ / ₁₆	27 ⁷ / ₈	74 ¹ / ₂	29 ³ / ₈	2 ¹⁹ / ₁₆	6 ¹ / ₂	3 ³ / ₁₆	7 ¹ / ₂	3/4	3/8
120	38	44 ¹ / ₂	27	28	31 ¹ / ₂	86	34 ³ / ₄	2 ¹⁵ / ₁₆	6 ¹ / ₂	3 ⁷ / ₁₆	8	3/4	3/8
132	41 ³ / ₄	49 ³ / ₄	29 ⁵ / ₁₆	30 ⁵ / ₁₆	33 ¹ / ₂	89 ¹ / ₂	37	3 ⁷ / ₁₆	8	3 ¹¹ / ₁₆	8 ¹ / ₂	3/4	3/8

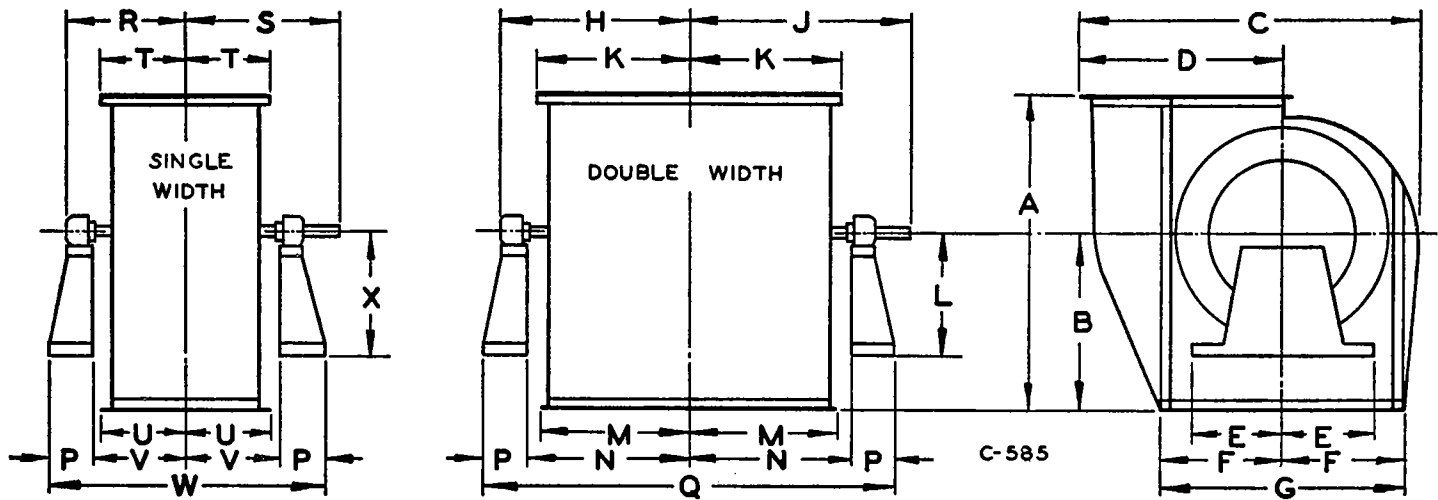

Fan Size	A	B	C	D	E	F	G	H	J	K	L	M	N	P	Q
30	30 1/4	16	29 7/8	17 7/8	10 1/2	12 1/8	24 1/4	17 7/16	21 3/16	12 3/4	11	12 3/4	13 15/16	5 1/2	38 7/8
33	32 1/4	17 1/4	32 5/16	19 3/8	10 1/2	12 7/8	25 3/4	17 7/8	22 3/8	13 15/16	11	13 15/16	14 1/2	5 1/2	40
36 1/2	34 3/4	18 3/4	35 5/8	21 1/4	12 1/4	14	28	19 15/16	24 9/16	15 3/16	14 3/8	15 3/16	15 15/16	6 7/8	45 5/8
40	37 1/2	20 1/2	38 13/16	23 1/8	12 1/4	15	30	21 1/8	26 1/8	16 1/2	14 3/8	16 1/2	17 1/4	6 7/8	48 1/4
44 1/2	41	22 1/2	42 15/16	25 1/2	12 1/4	16 1/2	33	22 5/8	27 5/8	18	14 3/8	18	18 3/4	6 7/8	51 1/4
49	44	24 1/2	46 7/8	27 3/4	14 1/2	17 1/2	35	25 1/2	30 3/4	19 3/4	17 1/2	19 3/4	21	7 7/8	57 3/4
54	48 3/4	26 3/4	51 1/16	30 3/8	14 1/2	19 1/2	39	27 1/2	32 3/4	21 1/16	17 1/2	21 1/16	23	7 7/8	61 3/4
60	53	29 1/2	56 7/8	33 1/2	14 3/4	21	42	29 13/16	35 5/16	23 3/16	21 3/4	23 3/16	25 1/8	8 3/8	67
66	57 1/4	32 1/4	62 1/4	36 3/8	14 3/4	22 1/2	45	32 5/16	37 13/16	25 13/16	21 3/4	26 13/16	27 5/8	8 3/8	72
73	62 1/2	35 1/2	68 9/16	40 1/4	14 3/4	24 1/2	49	35 1/8	41 3/8	28 5/16	26 1/4	29 5/16	30 1/4	8 3/8	77 1/4
80 1/2	66 3/4	38 3/4	75 5/8	44 7/16	14 3/4	25 1/2	51	40 1/2	46 3/4	31 1/8	26 3/4	31 15/16	34 3/8	8 3/8	85 1/2
89	73 1/2	42 3/4	83 1/2	48 15/16	14 3/4	28	56	43 7/8	50 1/8	34 1/8	26 3/4	34 15/16	37 3/4	8 3/8	92 1/4
98	81 1/4	47 1/4	91 5/8	53 5/8	17 1/2	30 1/2	61	47 5/8	54 1/8	37 7/16	29 3/8	38 3/4	41 1/2	9 3/8	101 3/4
108 1/2	89 1/4	52	101 1/8	59 1/8	17 1/2	33	66	51 7/8	59 3/8	41 1/8	29 5/8	42 7/16	45 1/8	9 3/8	109
120	99	57 3/4	112 5/8	66 1/4	19	36 1/2	73	58	66	46 1/4	35 3/8	47 1/16	50 1/2	11 1/2	124
132	108 1/2	63 1/4	123 5/8	72 1/16	18	40	80	63	71 1/2	50 1/16	37 1/8	51 5/16	54 1/2	11 1/4	131 1/2

Fan Size	R	S	T	U	V	W	X	SHAFT EXTENSION				Keyway in Drive Hub	
								SW		DW		SW & DW	
								Dia.	Length	Dia.	Length	Width	Depth
30	12 1/16	17 1/16	8	8	9 3/16	29 3/8	11	1 3/16	4 1/4	1 3/16	4 1/4	1/4	1/8
33	12 5/8	17 1/8	8 11/16	8 11/16	9 1/4	29 1/2	11	1 3/16	4 1/4	1 3/16	4 1/4	1/4	1/8
36 1/2	14 3/16	18 13/16	9 7/16	9 7/16	10 1/16	34 3/8	14 3/8	1 5/16	4 1/2	1 5/16	4 1/2	5/16	1/8
40	14 3/4	19 3/4	10 1/8	10 1/8	10 7/8	35 1/2	14 3/8	1 7/16	4 3/4	1 7/16	4 3/4	3/8	3/16
44 1/2	15 5/8	20 5/8	11	11	11 3/4	37 1/4	14 3/8	1 7/16	4 3/4	1 7/16	4 3/4	3/8	3/16
49	17 1/16	22 15/16	11 15/16	11 15/16	13 3/16	42 1/8	17 1/2	1 11/16	5	1 11/16	5	3/8	3/16
54	18 7/8	24 1/8	12 15/16	12 15/16	14 3/8	44 1/2	17 1/2	1 11/16	5	1 11/16	5	3/8	3/16
60	20 7/16	25 15/16	14 1/16	14 1/16	15 5/8	48	21 3/4	1 15/16	5 1/4	1 15/16	5 1/4	1/2	1/4
66	21 15/16	27 7/16	15 5/16	16 5/16	17 1/8	51	21 3/4	1 15/16	5 1/4	1 15/16	5 1/4	1/2	1/4
73	23 1/2	29 3/4	16 11/16	17 11/16	18 5/8	54	26 1/4	2 3/16	5 3/4	2 3/16	5 3/4	1/2	1/4
80 1/2	26 3/4	32 3/4	18 1/8	19 1/8	21 5/8	60	26 1/2	2 7/16	6	2 11/16	6 1/4	5/8	5/16
89	29 3/4	36	19 13/16	20 13/16	23 5/8	64	26 3/4	2 11/16	6 1/4	2 11/16	6 1/4	5/8	5/16
98	32	38 1/2	21 5/8	23 3/8	25 7/8	70 1/2	29 3/8	2 5/16	6 1/2	2 5/16	6 1/2	3/4	3/8
108 1/2	34	40 1/2	23 11/16	25 3/16	27 7/8	74 1/2	29 3/8	2 5/16	6 1/2	3 3/16	7 1/2	3/4	3/8
120	38	44 1/2	27	28	31 1/2	86	34 3/4	2 5/16	6 1/2	3 7/16	8	3/4	3/8
132	41 3/4	49 3/4	29 5/16	30 3/16	33 1/2	89 1/2	37	3 1/16	8	3 11/16	8 1/2	3/4	3/8