



ALLUFEM

SOLAR ENERGY
PROFILE CATALOGUE





SOLAR ENERGY

ALUFEM is among the leading compaines in the solar energy systems sector with its fundamental quality principles and its understanding that values the environment.

ALUFEM is aware of its responsibilities to leave a livable environment to the next generations and increases its investments in renewable naturel energy resources day by day using all its knowledge and opportunities.

Aluminium Solar Energy Systems of ALUFEM offer to the customers system designs that can be easily applied on construction sites with limited opportunities.

Our systems allow multi-module applications in all terrains, on floors with variable slopes, at different angles, in horizontal and vertical planes.

MISSION

As ALUFEM, our mission is to bring together the present durable raw material and high-quality production to see our meticulous workmanship and confidential brand in all areas needed, to provide solutions correctly and right on time and to response as quick as possible. It is also to struggle for perfect result by harmonizing our expertise and developing technology.

VISION

Our vision is to present production power of Anatolia to whole world by using ALUFEM signature. Also, It is to develop with aesthetic, high-quality and innovator products day by day. Besides all these, to chase technological innovations step by step is our afald vision.

ABOUT

With high-quality production, durable raw material and a strong vision, we send our products all around the world from Turkey by ALUFEM signature, and we keep growing proudly. By adding meticulous workmanship to high-quality raw material, we provide low cost production model. We make ourselves better equipped by using the technological developments that come with the developing world.

We provide our productions with basic quality principles to our clients and whole world with our forward-looking corporate identity. We are very proud to declare that we will be keeping to manufacture with our aesthetic, quality and expertise and also to provide creative solutions.

Best Regards.



CONTENTS

Page 5

SOLAR FRAME PROFILE

Page 8

FIXER CLAMPS PROFILE

Page 10

SOLAR RAIL PROFILE

Page 12

TILE ROOF PROFILE

Page 17

STRAIGHT ROOF SYSTEM



**Quality Production,
Innovative Design,
International Vision.**

**SOLAR FRAME
PROFILES**

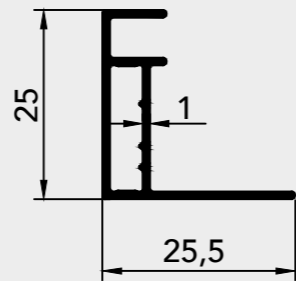

5152

0,224 Kg/M
25's Frame

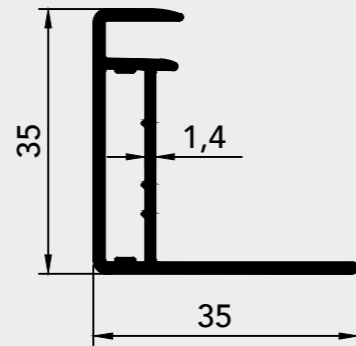

5150

0,450 Kg/M
35's Frame

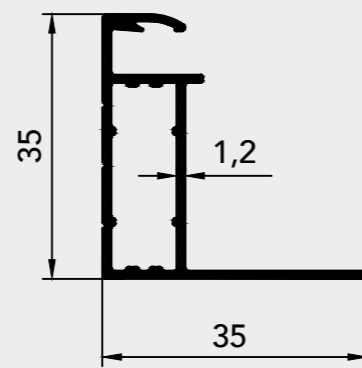

5155

0,382 Kg/M
35's Frame

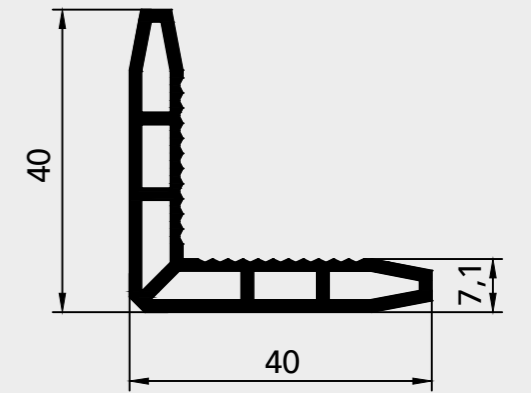
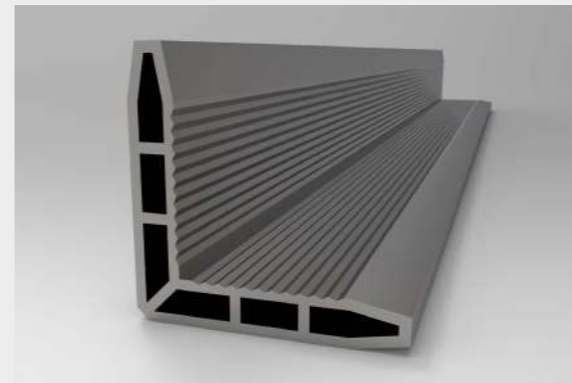

5156

0,699 Kg/M
Frame Corner Joint

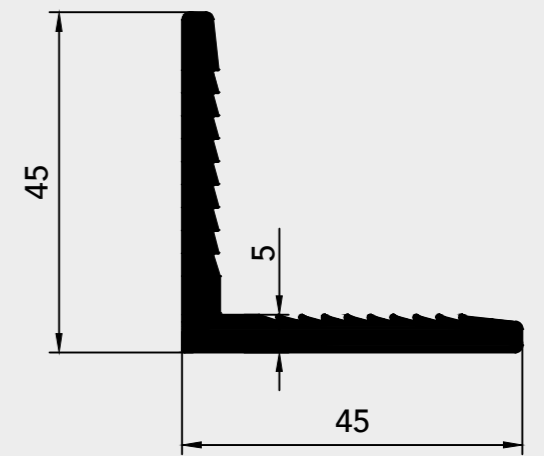
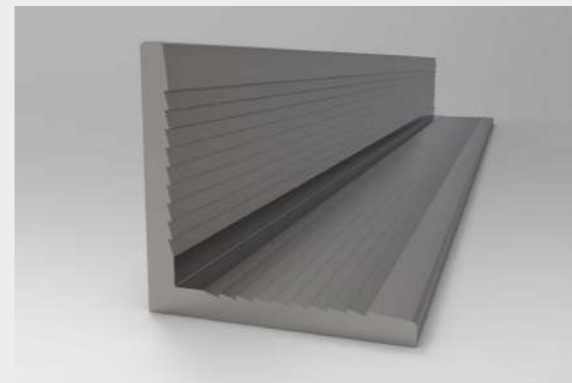

5151

1,040 Kg/M
Frame Corner Joint

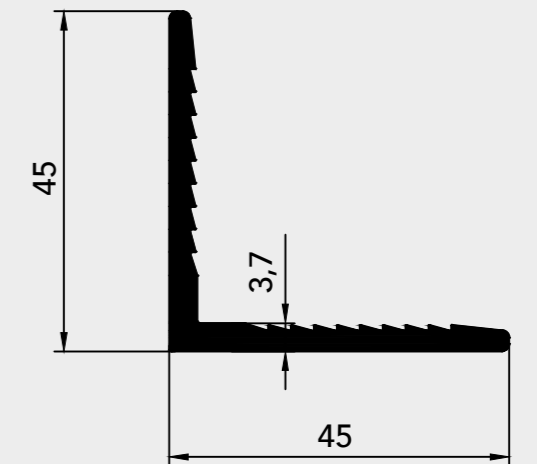
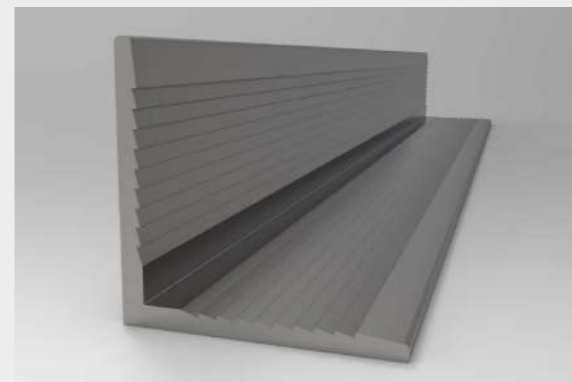

5153

0,758 Kg/M
Frame Corner Joint



FIXER CLAMP PROFILES



5172

0,499 Kg/M
Mid Fixer Clamp

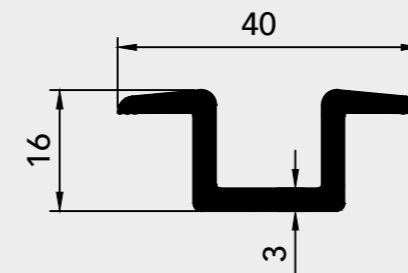

5154

0,377 Kg/M
Medium Profile

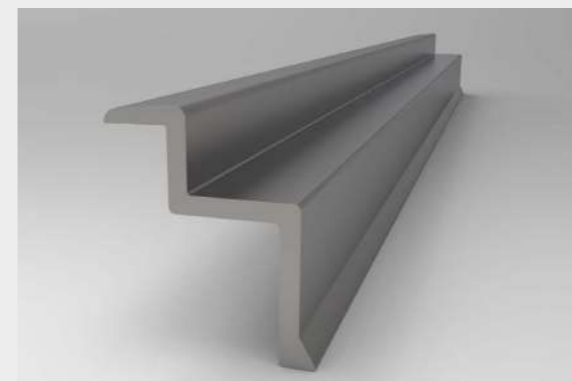
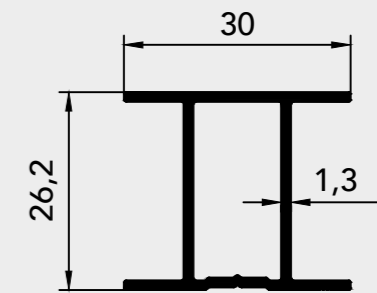

5175

0,527 Kg/M
Edge Fixing Clamp

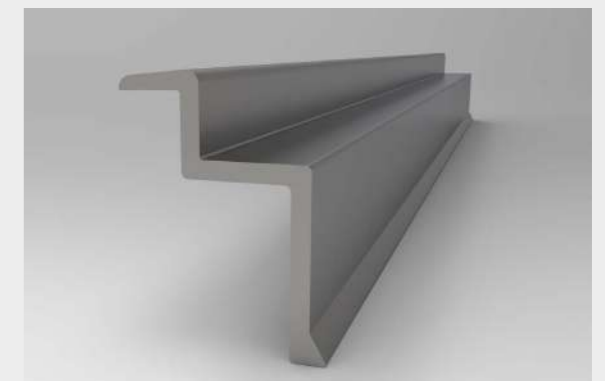
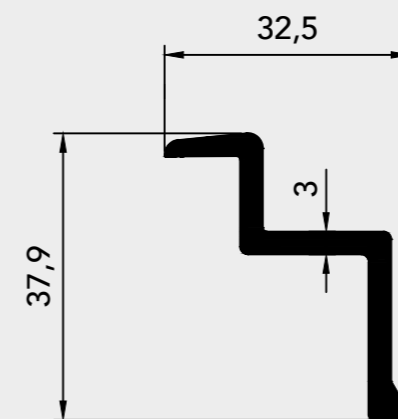

5173

0,569 Kg/M
Edge Fixing Clamp

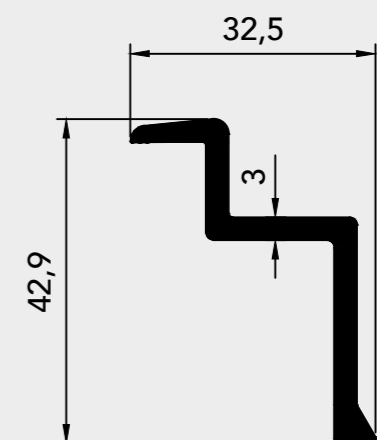



SOLAR RAIL PROFILES



5174

1,998 Kg/M
100's Raile

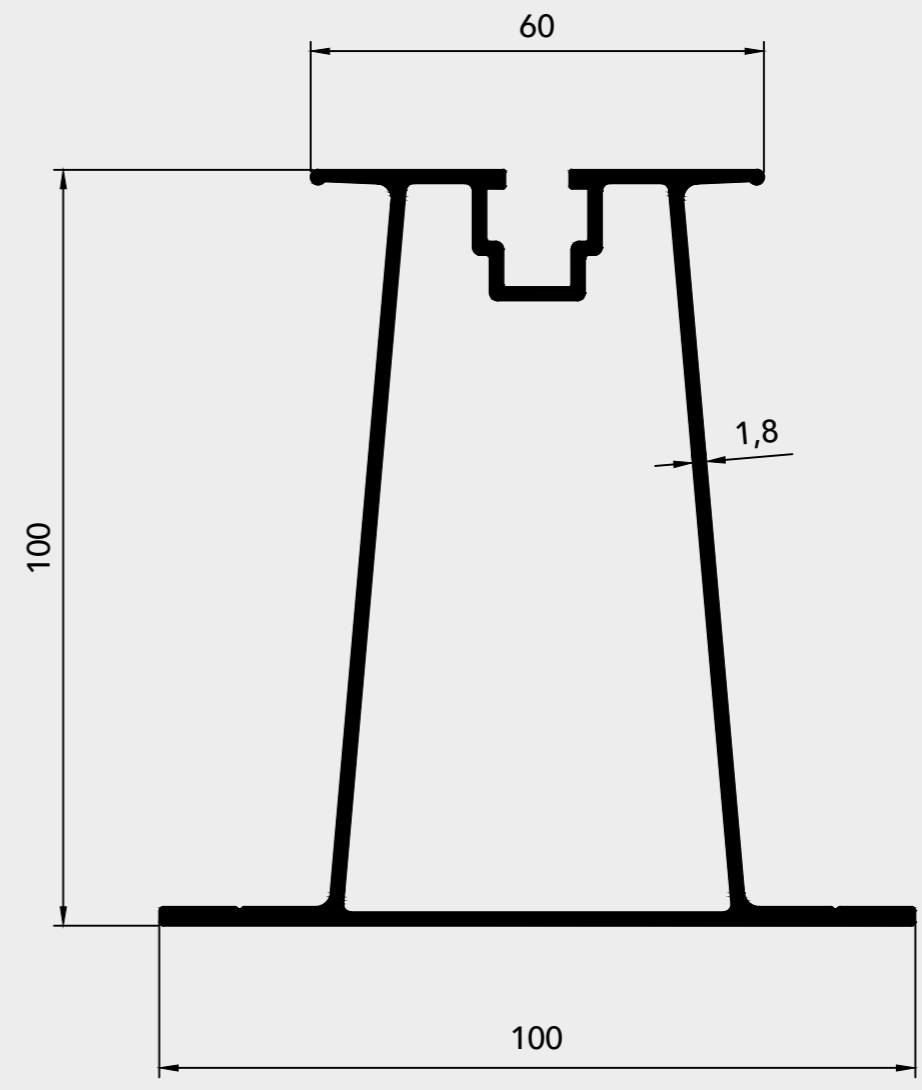



TILE ROOF PROFILES

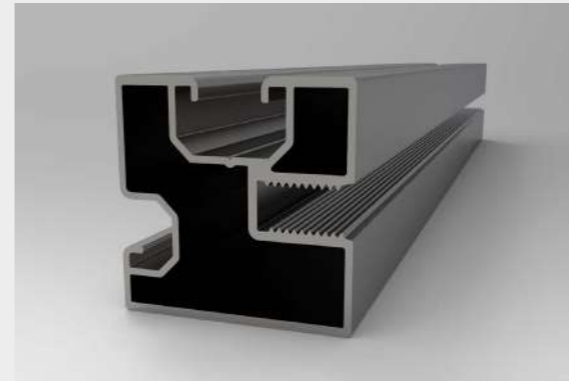

5177

0,908 Kg/M
40's Raile

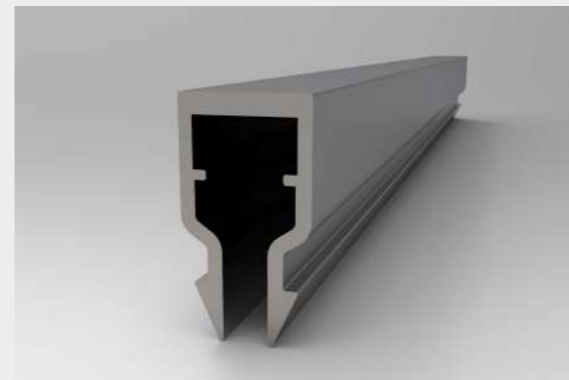
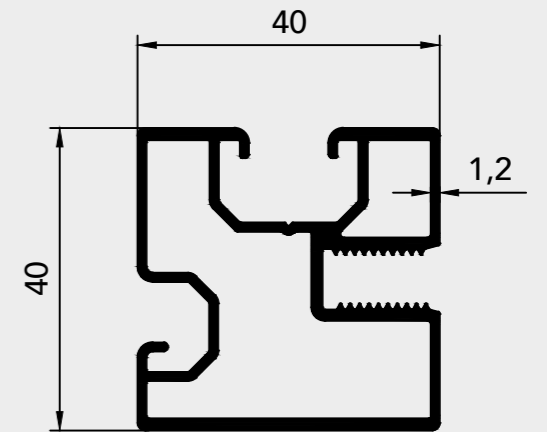

5178

0,477 Kg/M
Clamp Rail Connection

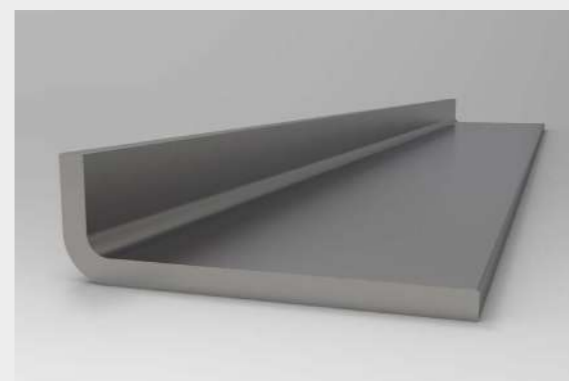
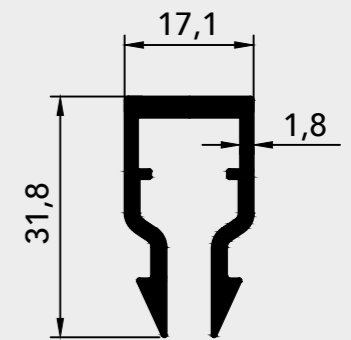

5179

0,434 Kg/M
Bracket

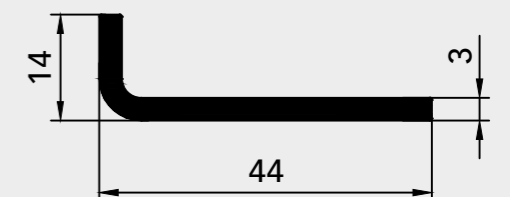

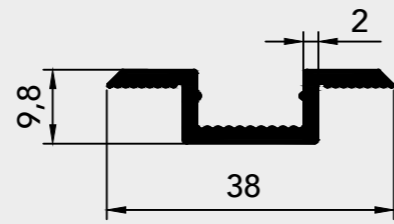
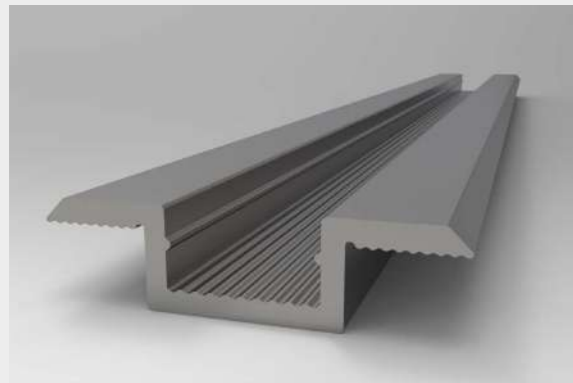

5180

0,301 Kg/M
Mid Fix Clamp

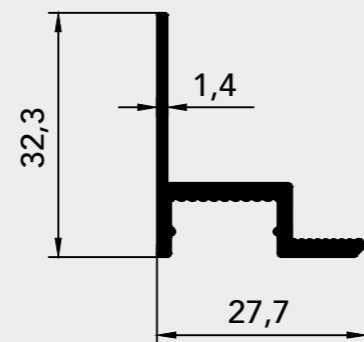
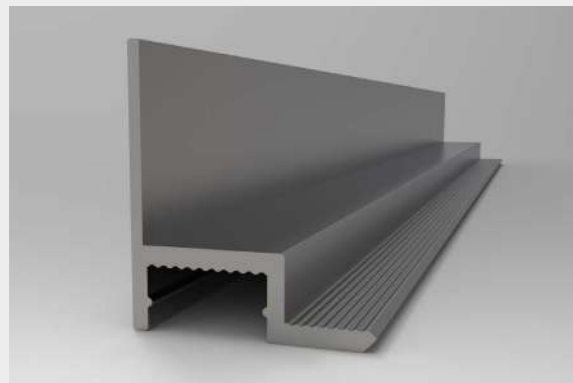

5181

0,331 Kg/M
Edge Fixing Clamp

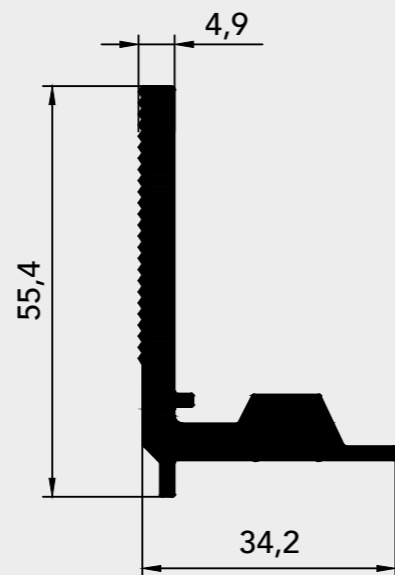
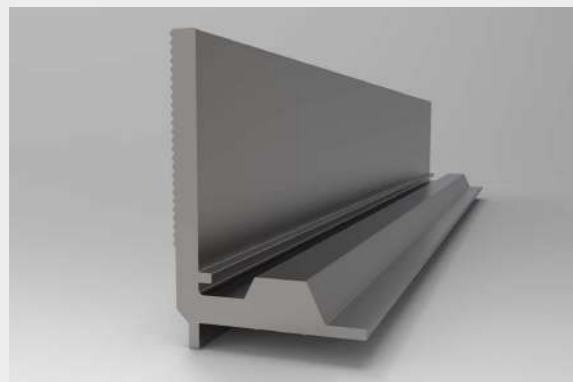

5184

1,117 Kg/M
Top Connection Part

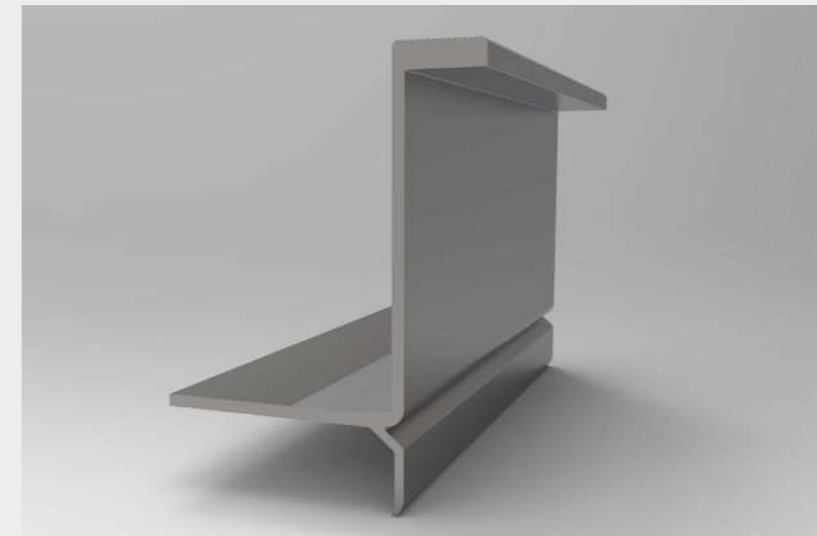

5182

4,715 Kg/M
Roof Connection Part

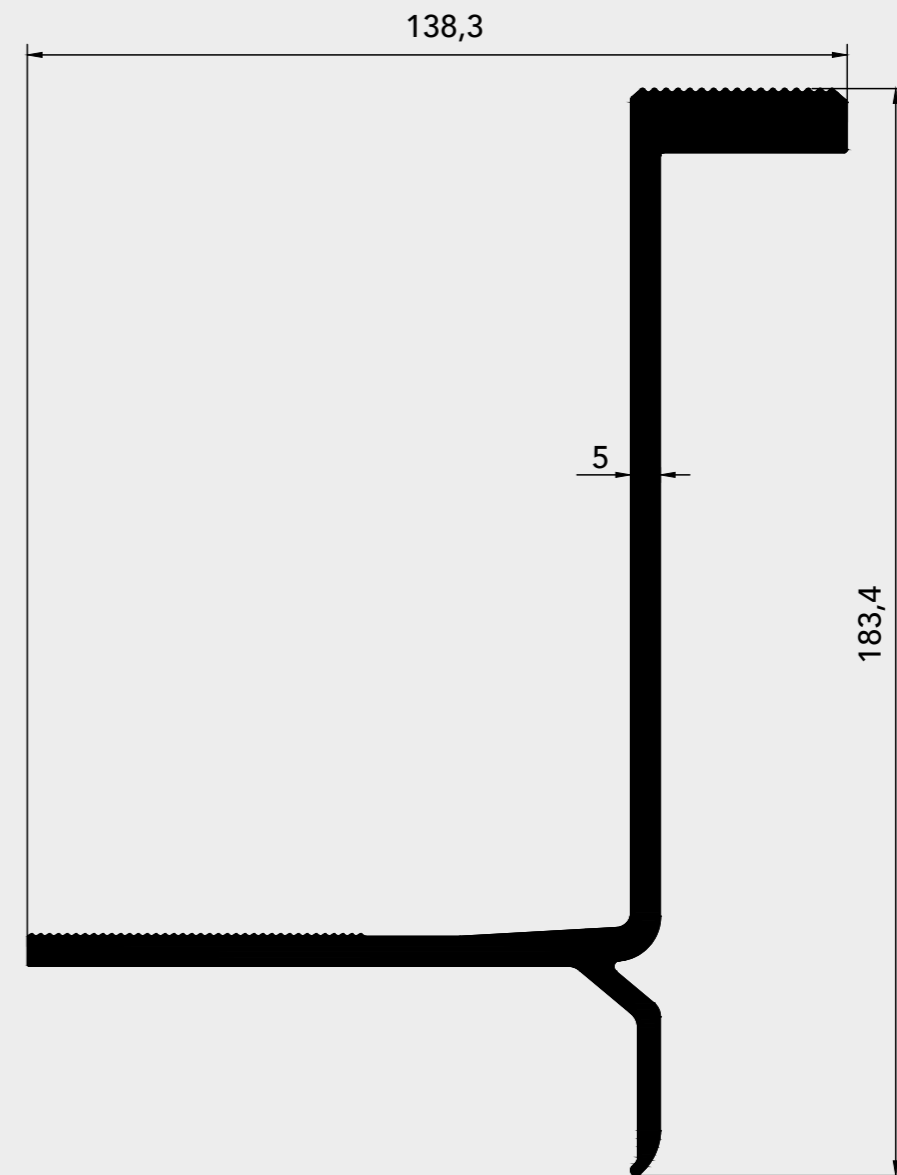

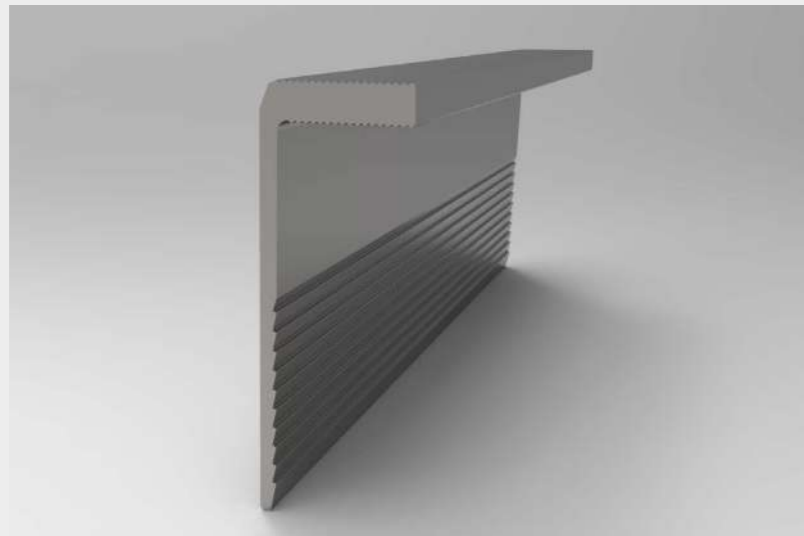

5183

2,523 Kg/M
Roof Connection Part Clips

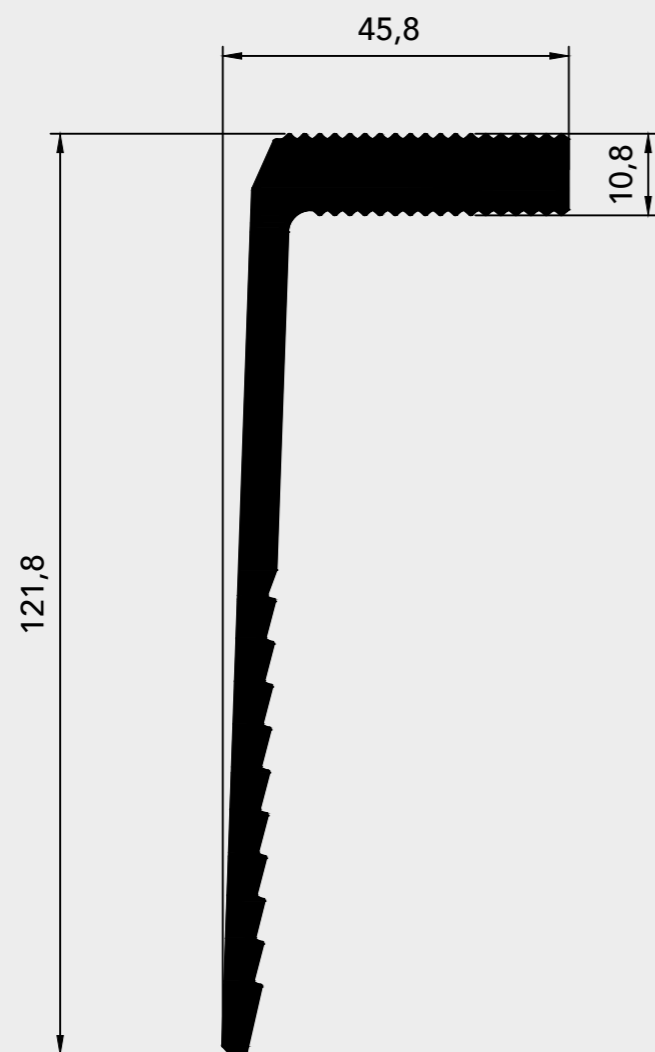

STRAIGHT ROOF SYSTEM

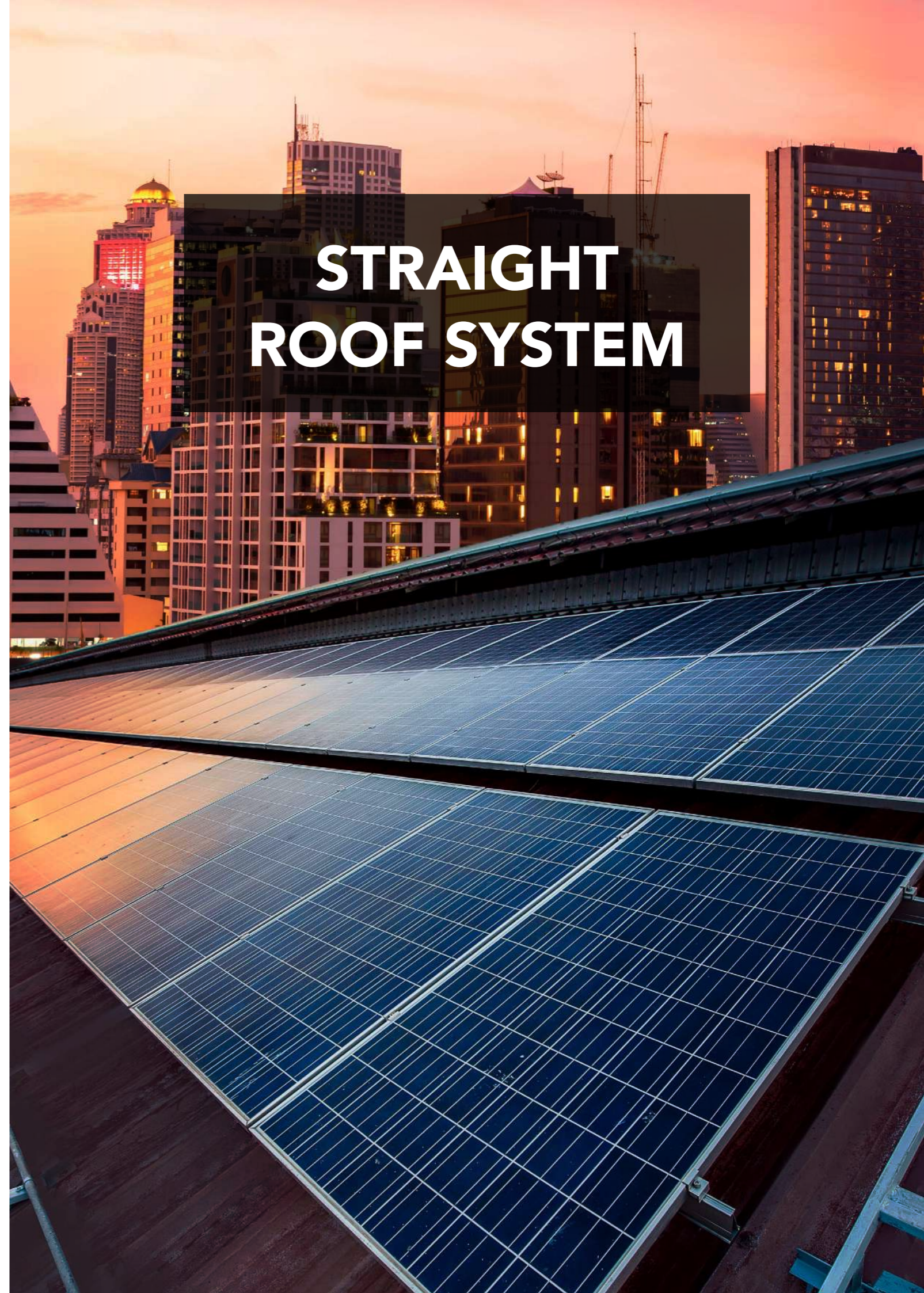

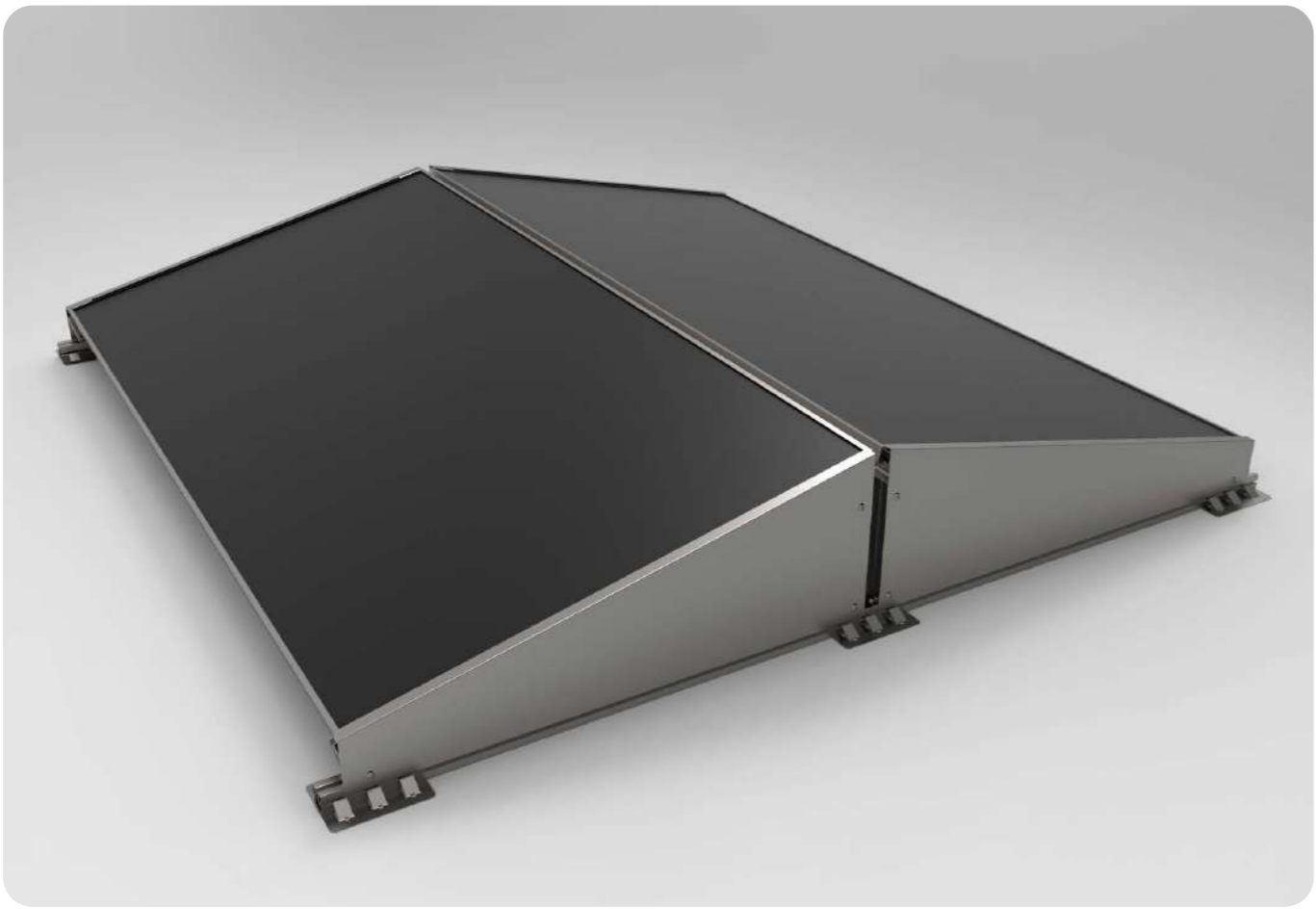



ALUFEM FACTORY



ALUFEM FACTORY

Built on a 14.000 m² closed area in Kayseri Organized Industrial Zone, Alufem Aluminium provides fast and innovative services to its customers with its aluminium extrusion press lines, polishing and surface treatment machines, anodizing and electrostatic powder coating facilities, CNC machining centers, assembly lines and its customer-oriented team of leading experts.



EXTRUSSION PRESS

Our company with 1100 US Tons (5") and 2000 US Tons (7") extrusion press lines, has a capacity of annually producing over 10.000 tons of aluminium profile of various alloys with the T0, T4, T5 and T6 heat treatment processes.

5"



5"







ANODIZING

In our anodizing facility, we are able to perform matte, glossy and satin finish plating up to a length of 7.5 meters with capacity of 4,000,000 m² / year. With our tin sulfate and nickel sulfate baths, we can meet customers coloring requests ranging from light bronze to black.



ELECTROSTATIC POWDER COATING PLANT

Our electrostatic powder coating facility serves in all RAL codes and architectural coating paints with a capacity of 4.000 tons/year. Our powder coating facility is designed to be isolated from external environmental effects; our production is carried out by a fully automatic process-controlled cabin system.

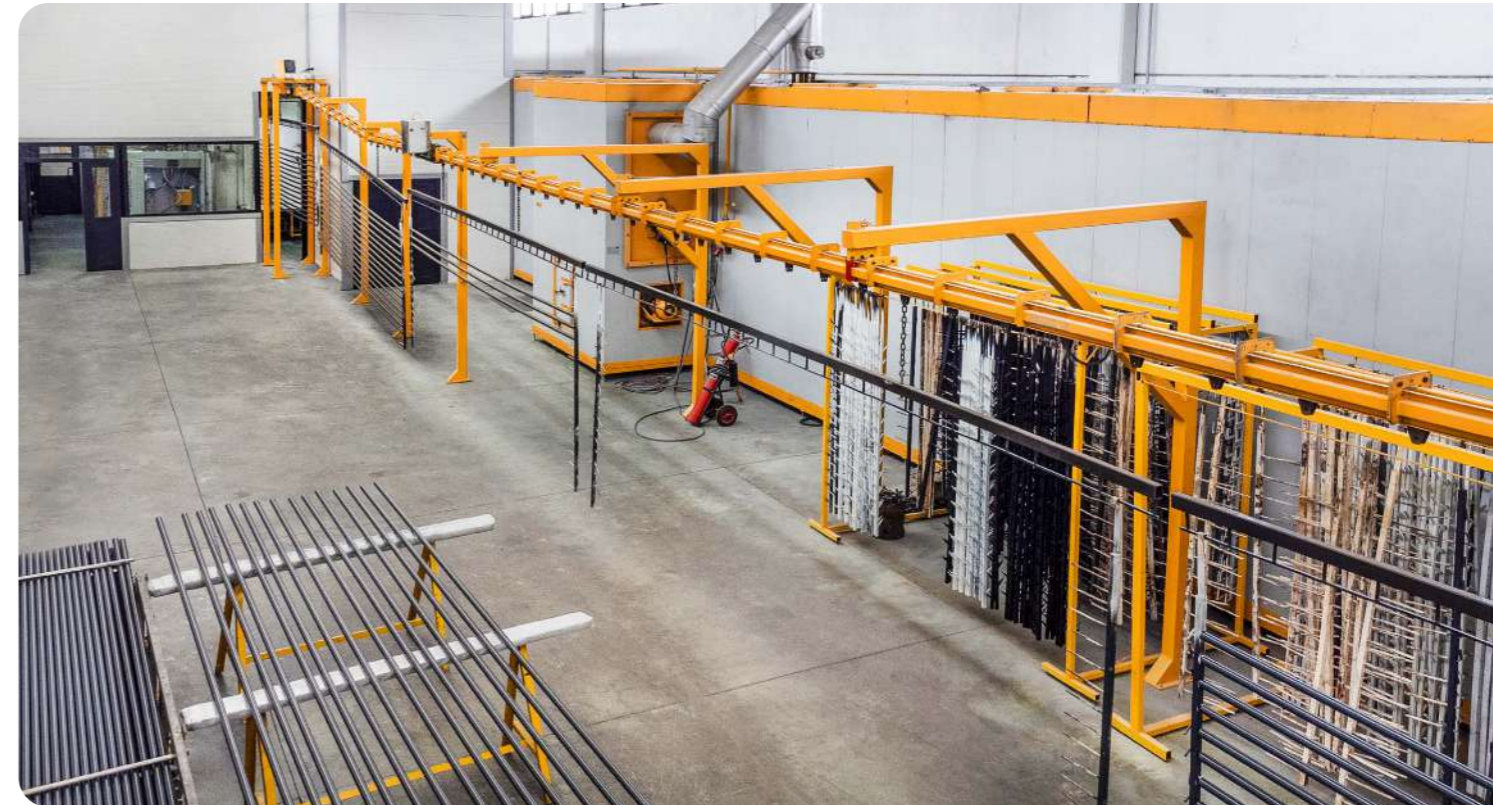



MECHANICAL PROCESS

With the 4 axis CNC profile machining centers, angled double-headed precision-cutting saws, and process specific custom machining lines by performing profile cutting, notching, drilling, countersinking, threading operations within or facilities, we actualize the mechanical process applications our clients need with delicacy and speed.

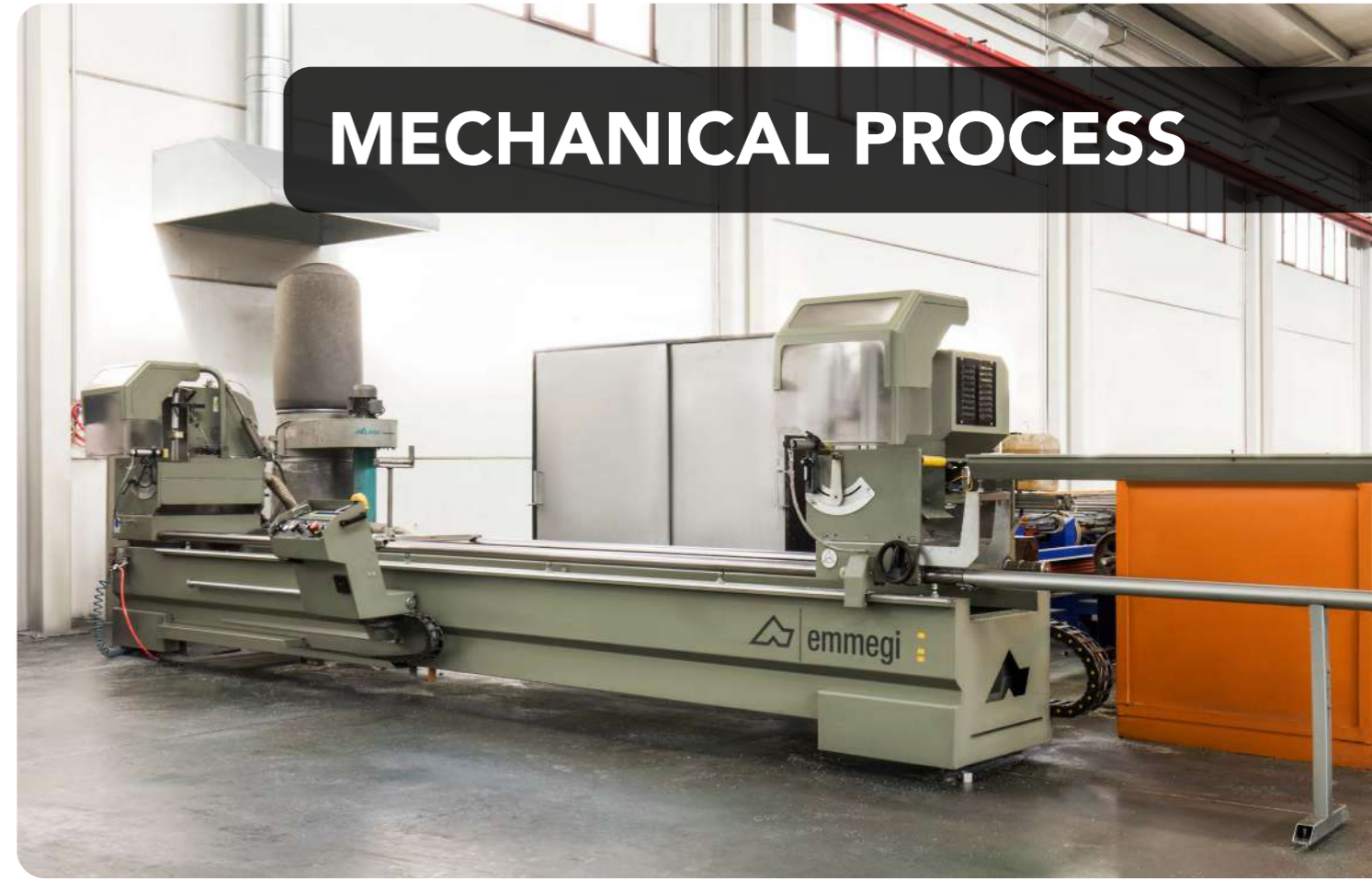

DIE UNIT



LABORATORY



PURIFICATION

As an indication of its understanding that ALUFEM brand values the environment and people, it has commissioned the most possible purification facility in today's conditions that has an annual capacity of 132,000 m³.





ALUFEM

ALUFEM ALÜMİNYUM SANAYİ VE TİCARET A.Ş.

Organize Sanayi Bölgesi 17. Cadde No: 2/A Melikgazi, Kayseri / TURKEY

Tel: +90 [352] 502 38 83 - Fax: +90 [352] 504 44 77

info@alufem.com.tr - www.alufem.com.tr

